

In most industrial countries STAUFF Clamps symbolise quick and easy pipe and hose installations as well as a clean distinct pipe layout.

The vibration and noise reducing features are appreciated as being an important contribution to environmental protection.

Apart from the technical sophistication of STAUFF Clamps, the second-to-none delivery, prompt service even for special constructions, STAUFF Clamps are also the most economical ones to install.

STAUFF Clamps applications are almost unlimited. Due to the extraordinary wide product range, almost all areas of pipe, tube, hose and cable installation are covered:

- .. Industrial Hydraulics
- .. Mobile Hydraulics
- .. Marine Hydraulics
- .. Offshore
- .. General Industrial Pipe Construction
- .. Mining Industry
- .. Nuclear Reactor Construction
- .. Instrumentation and Control Technology
- .. Pneumatics

STAUFF Clamps have been successfully tested and approved by several international organisations, including:

- .. Bureau Veritas
- .. Department of the Navy, New York
- .. Germanischer Lloyd
- .. Lloyd's Register of Shipping
- .. Registro Italiano Navale
- .. Russian Maritime Register of Shipping
- .. Technischer Überwachungsverein TÜV
- .. United States Coast Guard

Please do not hesitate to contact STAUFF for further details.



























www.stauff.com

A



















STAUFF Clamps









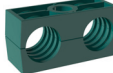
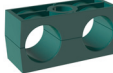

Index	A2
Standard Series (DIN 3015, Part 1)	A6
Heavy Series (DIN 3015, Part 2)	A24
Twin Series (DIN 3015, Part 3)	A40
Heavy Twin Series	A50
Compact Twin Series	A54
Agriculture Twin Series	A54
Plastic Saddle Clamps	A55
Custom-Designed Clamps	A56
Light Series	A58
Construction Series	A66
Flat and Round Steel U-Bolts	A68
Metal Pipe Clamps	A76
Heavy Saddles	A78
Light Saddles	A80
Cushion Clamp Series	A82
Industry-Specific Solutions	A84
Technical Appendix	A86

Standard Series (DIN 3015, Part 1)

	Clamp Body - Profiled Inside Surface (PP / PA / SA / AL)		A6		Safety Washer (DIN 93)	SI	A17
	Clamp Body - Smooth Inside Surface (PP / PA / SA)	H	A7		Safety Washer (DIN 463)	SI	A17
	Clamp Body with Rubber Insert (PP / PA)	RI	A8		Socket Cap Screw	IS	A18
	Clamp Body - Compact Design (PP / PA)	CC	A9		Slotted Head Screw	LI	A18
	Clamp Body - Rectangular Design (PP / PA)	VK	A9		Hexagon Head Bolt (for use with Insert ES / EP)	ASE	A18
	Clamp Body - Oval Design (PP / PA)		A9		Insert	ES / EP	A18
	Weld Plate	SP	A10		Safety Locking Plate	SIG	A19
	Elongated Weld Plate	SPV	A10		Stacking Bolt	AF	A19
	Twin Weld Plate	DSP	A11		Clamp Assemblies		A20
	Group Weld Plate	RAP	A11		Technical Appendix		A86
	Angled Weld Plate	WSP	A12				
	Bridge Weld Plate	BSP	A12				
	Multi-Group Weld Plate	RAP-MGR	A13				
	Clamp Body for Multi-Group Weld Plate (PP / PA)	MGR	A13				
	Hexagon Rail Nut	SM	A14				
	Mounting Rail	TS	A14				
	Channel Rail Adaptor	CRA	A15				
	Cover Plate	DP	A16				
	Hexagon Head Bolt (for use with Cover Plate DP)	AS	A16				

Heavy Series (DIN 3015, Part 2)
Twin Series (DIN 3015, Part 3)

	Clamp Body - Profiled Inside Surface (PP / PA / SA / AL)		A24
	Clamp Body - Smooth Inside Surface (PP / PA / SA)	H	A26
	Clamp Body with Rubber Insert (PP / PA)	RI	A27
	Weld Plate for Single Clamps	SPAL	A28
	Weld Plate for Double Clamps	SPAS	A28
	Elongated Weld Plate for Single Clamps	SPAL/DUEB	A29
	Elongated Weld Plate for Double Clamps	SPAS/DUEB	A29
	Mounting Rail Nut	GMV	A30
	Mounting Rail	STSV	A30
	Channel Rail Adaptor	CRA	A31
	Cover Plate for Single Clamps	DPAL	A32
	Cover Plate for Double Clamps	DPAS	A32
	Hexagon Head Bolt	AS	A33
	Socket Cap Screw	IS	A33
	Safety Washer (DIN 93)	SI	A34
	Safety Washer (DIN 463)	SI	A34
	Safety Locking Plate	SIP	A35
	Stacking Bolt	AF	A35
	Clamp Assemblies		A36
	Technical Appendix		A86

	Clamp Body - Profiled Inside Surface (PP / PA)		A40
	Clamp Body - Smooth Inside Surface (PP / PA)	H	A40
	Single Weld Plate	SP	A41
	Group Weld Plate	RAP	A41
	Hexagon Rail Nut	SM	A42
	Mounting Rail	TS	A42
	Channel Rail Adaptor	CRA	A43
	Cover Plate	GD	A44
	Hexagon Head Bolt	AS	A44
	Safety Locking Plate	SI	A45
	Safety Locking Plate	SIV	A45
	Stacking Bolt	AF	A46
	Clamp Assemblies		A47
	Technical Appendix		A86

Heavy Twin Series

	Clamp Body - Profiled Inside Surface (PP / PA)		A50
	Clamp Body with Rubber Inserts (PP / PA)	RI	A50
	Weld Plate	SPAD	A51
	Cover Plate	DPAD	A51
	Hexagon Head Bolt	AS	A52
	Mounting Rail Nut	GMV	A52
	Mounting Rail	STSV	A52
	Channel Rail Adaptor	CRA	A52
	Socket Cap Screw	IS	A52
	Safety Locking Plate	SIPD	A52
	Stacking Bolt	AF	A52
	Clamp Assemblies		A53

Plastic Saddle Clamps

	Saddle Clamps for Cylinder Supply Lines ZR 518	A55
	Custom-Designed Plastic Saddle Clamps	A55

Custom-Designed Clamps

	Machined Versions	A56
	Injection Moulded Versions (Flexi Clamps)	A57

Light Series - Types LBBU

	Clamp Body - Single Design	A58
	Clamp Body - Twin Design	A59
	Weld Plate LBBU-SP	A60
	Sleeve LBBU-HUE	A60
	Cover Plate LBBU-DP	A61
	Hexagon Head Bolt AS	A61

Compact Twin Series

	Clamp Body - Profiled Inside Surface (PP) DS1	A54
	Single Weld Plate SP DS1	A54
	Cover Plate US DS1	A54
	Hexagon Head Bolt AS DS1	A54

Light Series - Types LB/LBG/LBU



	Clamp Body - Single Design LB	A62
	Clamp Body - Twin Design LBG/LBU	A63



Agriculture Twin Series

	Clamp Body (PP) AG	A54
--	------------------------------	-----

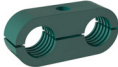

Light Series ■ Types LN/LNGF/LNUF

Heavy Saddles

	Clamp Body ■ Single Design	LN	A64
	Clamp Body ■ Twin Design	LNGF/LNUF	A65
	Cover Plate ■ Twin Design	DPL	A65







	Heavy Saddles ■ Single-Ended Design	DIN 1592	A78
	Heavy Saddles ■ Double-Ended Design	DIN 1593	A79

Construction Series

	Construction Series	KS / DKS	A66
	Construction Series (for Anchor Bolt Fastening)	KSV / DKSV	A67

	Light Saddles ■ Single-Ended Design	DIN 1596	A80
	Light Saddles ■ Double-Ended Design	DIN 1597	A81

Flat and Round Steel U-Bolts

	Flat Steel U-Bolt with Plastic Pipe Saddle (Short) and U-Profile	FB / RUK	A68
	Round Steel U-Bolt with Plastic Pipe Saddle (Short)	RB / RUK	A70
	Round Steel U-Bolt with Plastic Pipe Saddle (Long)	RB / RUL	A72
	Round Steel U-Bolt without Plastic Pipe Saddle	RBD	A74
	Rubber-Shrouded Round Steel U-Bolt	RSU	A75
	Rubber-Lined Flat Steel U-Bolt	LUS	A75

Cushion Clamp Series

	Cushion Clamp Series	STC / SPC	A82
	Channel Rail	SCS	A83

Industry-Specific Solutions

	For Power Plants	A84
	For Wind Power Stations	A84
	For Rail Technology Applications	A84
	For Process Technology Applications	A84
	For Sub-Sea Pipeline Applications	A84

Metal Pipe Clamps

	Metal Pipe Clamp with Rounded Ends	DIN 3567-A	A76
	Metal Pipe Clamp with Rounded Ends and One-Side Elongated Shaft	DIN 3567-B	A77

Technical Appendix

Standard Clamp Body Materials	A86
Standard Rubber Insert Materials	A86
Special Clamp Body Materials	A87
Standard Clamp Body Designs	A88
Materials and Surface Finishings of Metal Parts	A89
Property Classes / Grades of Bolts and Screws	A89
Thread Conversion Chart	A89
General Installation Instructions	A90
Tightening Torques / Maximum Loads in Pipe Direction	A91
Dimensions and Weights of Clamp Assemblies	A92
Packaging Units (Selection)	A93

Clamp Body - Profiled Design

Profiled Inside Surface with Tension Clearance

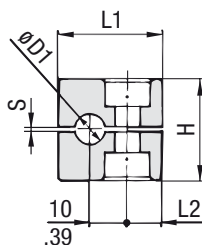
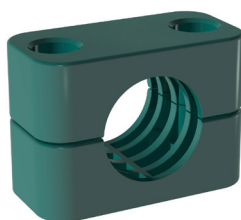

STAUFF Group 1

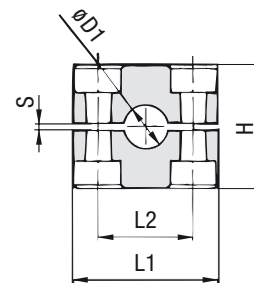

STAUFF Group 1A to 8

Order Codes

Clamp Body

Clamp Body, STAUFF Group 1A

*1*06*PP

*1*06A*PP

One clamp body is consisting of two clamp halves.

- * STAUFF Group **1**
- * Exact outside diameter Ø D1 (mm) **06**
- * Material code (see below) **PP**

Standard Materials



Polypropylene

Colour: Green
Material code: **PP**



Polyamide

Colour: Black
Material code: **PA**



Thermoplastic Elastomer (87 Shore-A)

Colour: Black
Material code: **SA**



Aluminium

Colour: Self-Colour
Material code: **AL**

See page A86 for material properties and technical information.

Special Materials

Please consult STAUFF for further details on fire-proof and corrosion preventing clamp body materials, tested and approved according to several international fire-protection standards.

See page A87 for material properties and technical information.

Product Features

- ** Proven, tested and trusted product in various markets
- ** Recommended for the safe installation of rigid pipes and tubes
- ** Available for all commonly used pipe and tube outside diameters
- ** Environmental protection due to vibration/noise reducing design
- ** Excellent weathering resistance, even under extreme conditions

Group	STAUFF	DIN	Outside Diameter		Nominal Bore		Order Codes (2 Clamp Halves) (* = Material)	Dimensions (mm/in)				
			Pipe / Tube Ø D1 (mm)	(in)	Pipe (in)	Copper Tube (in)		L1	L2	H	S min.	Width
1		0	6				106 **	28	9,5	27	0,4	30
			6,4	1/4			106,4 **					
			8	5/16			108 **					
			9,5	3/8		1/4	109,5 **					
			10		1/8		110 **					
1A		1	6				106A **	37	20	27	0,4	30
			6,4	1/4			106,4A **					
			8	5/16			108A **					
			9,5	3/8		1/4	109,5A **					
			10		1/8		110A **					
2		2	12				112 **	42	26	33	0,6	30
			12,7	1/2		3/8	212,7 **					
			13,5		1/4		213,5 **					
			14				214 **					
			15				215 **					
3		3	16	5/8		1/2	216 **	1,65	1,02	1,30	0,02	1,18
			17,2		3/8		217,2 **					
			18				218 **					
			19	3/4			319 **					
			20				320 **					
4		4	21,3		1/2		321,3 **	50	33	36	0,6	30
			22			3/4	322 **					
			25				325 **					
			25,4	1			325,4 **					
			26,9		3/4		426,9 **					
5		5	28				428 **	59	40	42	0,6	30
			28,6			1	428,6 **					
			30				430 **					
			32				432 **					
			32	1-1/4			532 **					
6		6	33,7		1		533,7 **	71	52	58	0,8	30
			35			1-1/4	535 **					
			38	1-1/2			538 **					
			40				540 **					
			41,3			1-1/2	541,3 **					
7		7	42		1-1/4		542 **	2,80	2,05	2,28	0,03	1,18
			44,5	1-3/4			644,5 **					
			48,3		1-1/2		648,3 **					
			50,8	2			650,8 **					
			54			2	654 **					
8		8	57,2	2-1/4			757,2 **	121	94	93	0,8	30
			60,3		2		760,3 **					
			63,5	2-1/2			763,5 **					
			70	2-3/4			770 **					
			73		2-1/2 (ANSI B 36-10)		773 **					
8		8	76,1	3	2-1/2 (DIN EN 10220)		776,1 **	4,76	3,70	3,66	0,03	1,18
			88,9		3		888,9 **					
			102	4	3-1/2		8102L **	5,79	4,72	4,65	0,03	1,18

Additional outside diameters are available upon request. Please consult STAUFF for further information.

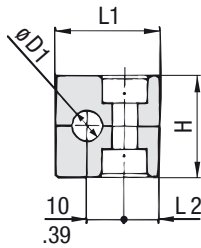

STAUFF Group 1

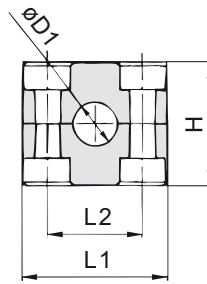

STAUFF Group 1A to 8

Clamp Body ▪ Type H

Smooth Inside Surface without Tension Clearance

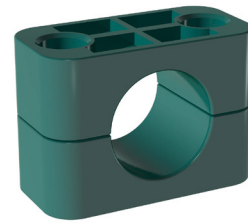

Group	STAUFF	DIN	Outside Diameter		Nominal Bore Hydraulic Hose SAE 100 R2 AT (in)	Order Codes (2 Clamp Halves) (*** = Material)	Dimensions (mm/in)			
			Ø D1 (mm)	(in)			L1	L2	H	Width
1	0	6			106 ***					
		6,4	1/4		106,4 ***					
		8	5/16		108 ***	28	9,5	26	30	
		9,5	3/8		109,5 ***	1.10	.37	1.02	1.18	
		10			110 ***					
		12			112 ***					
1A	1	6			106A ***					
		6,4	1/4		106,4A ***					
		8	5/16		108A ***	37	20	27	30	
		9,5	3/8		109,5A ***	1.46	.79	1.06	1.18	
		10			110A ***					
		12			112A ***					
2	2	12,7	1/2		212,7 ***					
		13,5			213,5 ***					
		14			214 ***	42	26	32	30	
		15			215 ***	1.65	1.02	1.26	1.18	
		16	5/8		216 ***					
		17,2			217,2 ***					
		18			218 ***					
3	3	13,4		1/4	313,4 ***					
		17,4		3/8	317,4 ***					
		19	3/4		319 ***					
		20			320 ***					
		20,5		1/2	320,5 ***	50	33	35,5	30	
		21,3			321,3 ***	1.97	1.30	1.40	1.18	
		22			322 ***					
		23,9		5/8	323,9 ***					
		25			325 ***					
		25,4	1		325,4 ***					
4	4	26,9			426,9 ***					
		28			428 ***	59	40	41,5	30	
		30			430 ***	2.32	1.57	1.63	1.18	
		32			432 ***					
5	5	27,8		3/4	527,8 ***					
		32	1-1/4		532 ***					
		33,7			533,7 ***					
		35			535 ***					
		35,7		1	535,7 ***	71	52	56,5	30	
		38	1-1/2		538 ***	2.80	2.05	2.22	1.18	
		40			540 ***					
		42			542 ***					
		43,8		1-1/4	543,8 ***					
6	6	44,5	1-3/4		644,5 ***					
		48,3			648,3 ***					
		49,8		1-1/2	649,8 ***	86	66	64,5	30	
		50,8	2		650,8 ***	3.39	2.60	2.54	1.18	
		54			654 ***					
7	7	57,2	2-1/4		757,2 ***					
		60,3			760,3 ***					
		63,5	2-1/2		763,5 ***	121	94	92	30	
		70	2-3/4		770 ***	4.76	3.70	3.62	1.18	
		73			773 ***					
		76,1	3		776,1 ***					
8	8	88,9			888,9 ***	147	1	116	30	
		102	4		8102L ***	5.79	4.72	4.57	1.18	

Order Codes
Clamp Body *1*06*PPH
Clamp Body, STAUFF Group 1A *1*06A*PPH

One clamp body is consisting of two clamp halves.

* STAUFF Group	1
* Exact outside diameter Ø D1 (mm)	06
* Material code (see below)	PPH

Standard Materials
Polypropylene
 Colour: Green
 Material code: **PPH**
Polyamide
 Colour: Black
 Material code: **PAH**
Thermoplastic Elastomer (87 Shore-A)
 Colour: Black
 Material code: **SAH**

See page A86 for material properties and technical information.

Special Materials

Please consult STAUFF for further details on fire-proof and corrosion preventing clamp body materials, tested and approved according to several international fire-protection standards.

See page A87 for material properties and technical information.

Product Features

- Proven, tested and trusted product in various markets
- Recommended for the safe installation of hoses and cables
- Chamfered edges avoid damaging of the hoses and cables
- Available for all commonly used hose and cable outside diameters
- Excellent weathering resistance, even under extreme conditions

Additional outside diameters are available upon request. Please consult STAUFF for further information.

Clamp Body with Rubber Insert Type RI

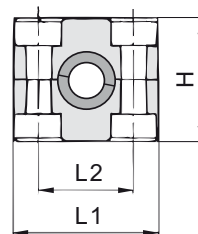
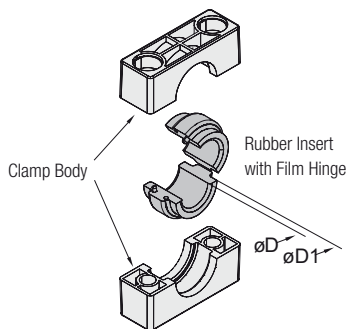

Order Codes

Clamp Assembly *4*06*PPR
 One assembly is consisting of one clamp body and one insert.

- * STAUFF Group **4**
- * Exact outside diameter Ø D (mm) **06**
- * Material code (see below) **PPR**

Clamp Body *4*PPR
 One clamp body is consisting of two clamp halves.

- * STAUFF Group **4**
- * Material code (see below) **PPR**

Rubber Insert *RI*06*(4+4S)
 * Rubber Insert **RI**

- * Exact outside diameter Ø D (mm) **06**
- * STAUFF Group 4 (Standard) and 4S (Heavy) **(4+4S)**
- 6 (Standard) and 5S (Heavy) **(6+5S)**

Group	STAUFF	DIN	Outside Diameter		Order Codes (**R = Clamp Body Material)			Dimensions				
			Pipe / Tube / Hose	Ø D	Clamp Assembly (Clamp Body + Rubber Insert)	Clamp Body (2 Clamp Halves)	Rubber Insert *	(mm/in)				
			(mm)	(in)				Ø D1	L1	L2	H	Width
4	4	4	6		406 **R	4 **R	RI 06 (4+4S)	25 .98	59 2.32	40 1.57	41,2 1.62	30 1.18
			8	5/16	408 **R		RI 08 (4+4S)					
			10		410 **R		RI 10 (4+4S)					
			12		412 **R		RI 12 (4+4S)					
			12,7	1/2	412,7 **R		RI 12,7 (4+4S)					
			14		414 **R		RI 14 (4+4S)					
			15		415 **R		RI 15 (4+4S)					
			16	5/8	416 **R		RI 16 (4+4S)					
			17,2		417,2 **R		RI 17,2 (4+4S)					
			18		418 **R		RI 18 (4+4S)					
6	6	6	20		620 **R	6 **R	RI 20 (6+5S)	38 1.50	86 3.39	66 2.60	64,5 2.54	30 1.18
			21,3		621,3 **R		RI 21,3 (6+5S)					
			22	7/8	622 **R		RI 22 (6+5S)					
			25		625 **R		RI 25 (6+5S)					
			26,9		626,9 **R		RI 26,9 (6+5S)					
			28		628 **R		RI 28 (6+5S)					
			30		630 **R		RI 30 (6+5S)					
			32	1-1/4	632 **R		RI 32 (6+5S)					

Standard Materials



Polypropylene
 Colour: Black
 Material code: **PPR**



Polyamide
 Colour: Black
 Material code: **PAR**



Rubber Insert
Thermoplastic Elastomer (73 Shore-A)
 Colour: Black

See page A86 for material properties and technical information.

Special Materials

Please consult STAUFF for further details on fire-proof and corrosion preventing clamp body materials, tested and approved according to several international fire-protection standards.

See page A87 for material properties and technical information.

Product Features

- Proven, tested and trusted product in various markets
- Either for the extra vibration/noise reducing installation of pipes and tubes or the extra gentle installation of hoses and cables
- Available for all commonly used outside diameters
- Excellent weathering resistance, even under extreme conditions

* Rubber Inserts for Standard Series clamp bodies, STAUFF Group 4 also fit into Heavy Series clamp bodies, STAUFF Group 4S. Rubber Inserts for Standard Series clamp bodies, STAUFF Group 6 also fit into Heavy Series clamp bodies, STAUFF Group 5S.

Additional outside diameters are available upon request. Please consult STAUFF for further information.

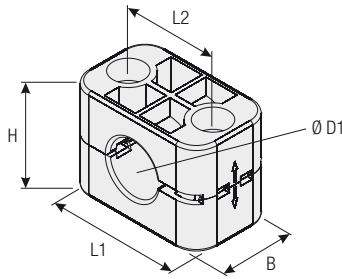
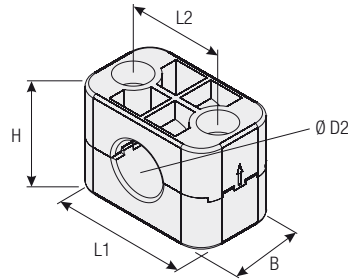
For Use with Regular Hose

For Use with Compact Hose
(Upper Clamp Half rotated by 180°)

Group	STAUFF	DIN	Outside Diameter Regular Hose		Outside Diameter Compact Hose		Order Codes (2 Clamp Halves) (*** = Material)	Dimensions (mm/in)				
			Ø D1 (mm)	(in)	Ø D2 (mm)	(in)		L1	L2	H		
3	3	19	.75	17,4	.69	319 ***-CC	50 1.97	33 1.30	35,5 1.40	34 1.34	30 1.18	
		22,2	.87	20,6	.81	322,2 ***-CC						
		25,4	1.00	23,7	.93	325,4 ***-CC						

Additional outside diameters are available upon request. Please consult STAUFF for further information.

Product Features

- Only one clamp body required for two different hose diameters (compact hose + regular hose)
- Rotate upper clamp half by 180° and use clamp body to fasten compact hoses instead of regular hoses
- Available for three different combination of outside hose diameters
- Outer dimensions according to DIN 3015, Part 1
- Effective cost reduction due to lower inventories

Special Materials

Please consult STAUFF for further details on fire-proof and corrosion preventing clamp body materials, tested and approved according to several international fire-protection standards.

See page A87 for material properties and technical information.

Order Codes

Clamp Body ***3*19*PPH-CC**

One clamp body is consisting of two clamp halves.

- * STAUFF Group **3**
- * Outside diameter Ø D1 (mm) of regular hose **19**
- * Material code (see below) **PPH-CC**

Standard Materials

Polypropylene
Colour: Black
Material code: **PPH-CC**

Polyamide
Colour: Black
Material code: **PAH-CC**

See page A86 for properties and technical information.

Clamp Body ▪ Rectangular Design Type VK

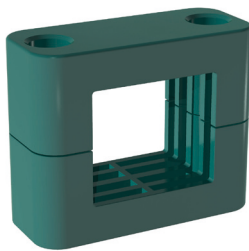

Order Codes

One clamp body is consisting of two clamp halves.

Clamp Body **540-40 PP-VK**
Rectangular design with a square of 40 mm x 40 mm / 1.57 in x 1.57 in

Clamp Body **540-36 PP-VK**
Rectangular design with a square of 40 mm x 36 mm / 1.57 in x 1.42 in

Please replace PP by PA to order a clamp body made of Polyamide instead of Polypropylene.

Product Features

- Outer dimensions of clamp body according to Standard Series, STAUFF Group 5
- For proximity switches according to DIN EN 60947-5-2 or similar, rectangular construction, with a square of 40 mm x 40 mm / 1.57 in x 1.57 in or 40 mm x 36 mm / 1.57 in x 1.42 in
- For proximity switches according to DIN EN 60947-5-2 or similar, round construction, please use Standard Series clamp body, STAUFF Group 4, with the diameter required (e.g. 430 PP)
- Use with Hexagon Rail Nut SM and Mounting Rail TS to provide axial and horizontal position adjustment when loosening the bolts

Clamp Body ▪ Oval Design

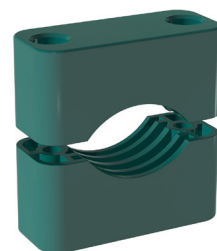

Order Codes

One clamp body is consisting of two clamp halves.

Clamp Body **620-50 PP**
Oval design with a diameter between 20 mm / .79 in and 50 mm / 1.97 in

Please replace PP by PA to order a clamp body made of Polyamide instead of Polypropylene.

Product Features

- Outer dimensions of clamp body according to Standard Series, STAUFF Group 6
- For electric cables with diameters between 20 mm / .79 in and 50 mm / 1.97 in
- For electric cables with diameters between 40 mm / 1.57 in and 72 mm / 2.83 in, please use Heavy Series clamp body, types 6040-72 PP and 6040-72 PA
- Recommended to use with Hexagon Head Bolts AS and Cover Plate DP, Socket Cap Screw IS (with washer) or Slotted Head Screw LI (with washer)
- For varying cable diameters, only the bolt lengths need to be varied

Single Weld Plate Type SP

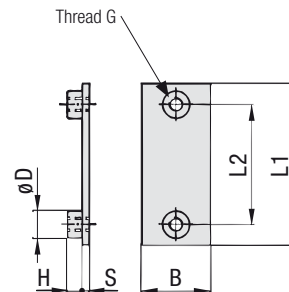
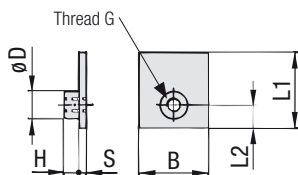
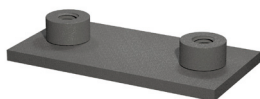

STAUFF Group 1

STAUFF Group 1A to 8

Order Codes

Weld Plate

***SP*1*M*W2**

- * Single Weld Plate **SP**
- * STAUFF Group **1**
- * Thread code Metric ISO thread **M**
 Unified coarse (UNC) thread **U**
- * Material code Carbon Steel, untreated **W1**
 Carbon Steel, phosphated **W2**
 Carbon Steel, zinc/nickel-plated **W3**

 Stainless Steel V2A **W4**
 1.4301 / 1.4305 (AISI 304 / 303)
 Stainless Steel V4A **W5**
 1.4401 / 1.4571 (AISI 316 / 316 Ti)

Group	STAUFF	DIN	Dimensions (mm/m)						ØD	Order Codes (Standard Options)
			Thread G	L1	L2	B	S	H		
1	0		M6	31,5	10	30	3	6,5	12	SP 1 M W2
			1/4-20 UNC	1.24	0.39	1.18	.12	.26	.47	SP 1 U W2
1A	1		M6	36	20	30	3	6,5	12	SP 1A M W2
			1/4-20 UNC	1.42	0.79	1.18	.12	.26	.47	SP 1A U W2
2	2		M6	42	26	30	3	6,5	12	SP 2 M W2
			1/4-20 UNC	1.65	1.02	1.18	.12	.26	.47	SP 2 U W2
3	3		M6	50	33	30	3	6,5	12	SP 3 M W2
			1/4-20 UNC	1.97	1.30	1.18	.12	.26	.47	SP 3 U W2
4	4		M6	60	40	30	3	6,5	12	SP 4 M W2
			1/4-20 UNC	2.36	1.57	1.18	.12	.26	.47	SP 4 U W2
5	5		M6	71	52	30	3	6,5	12	SP 5 M W2
			1/4-20 UNC	2.80	2.05	1.18	.12	.26	.47	SP 5 U W2
6	6		M6	88	66	30	3	6,5	12	SP 6 M W2
			1/4-20 UNC	3.46	2.60	1.18	.12	.26	.47	SP 6 U W2
7	7		M6	122	94	30	5	6,5	12	SP 7 M W2
			1/4-20 UNC	4.80	3.70	1.18	.20	.26	.47	SP 7 U W2
8	8		M6	148	120	30	5	6,5	12	SP 8 M W2
			1/4-20 UNC	5.83	4.72	1.18	.20	.26	.47	SP 8 U W2

All threaded parts are available with Metric ISO thread or unified coarse (UNC) thread according to dimension table. Alternative materials and surface finishings are available upon request. Consult STAUFF for further information.

Elongated Weld Plate Type SPV

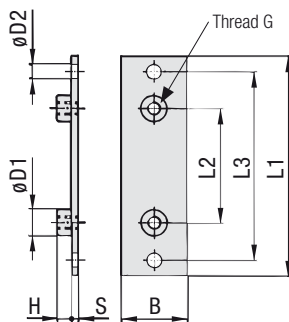
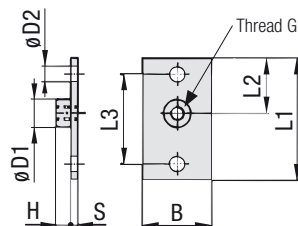
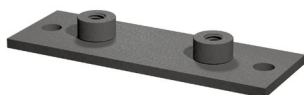

STAUFF Group 1

STAUFF Group 1A to 8

Order Codes

Weld Plate

***SPV*1*M*W2**

- * Elongated Weld Plate **SPV**
- * STAUFF Group **1**
- * Thread code Metric ISO thread **M**
 Unified coarse (UNC) thread **U**
- * Material code Carbon Steel, untreated **W1**
 Carbon Steel, phosphated **W2**
 Carbon Steel, zinc/nickel-plated **W3**

 Stainless Steel V2A **W4**
 1.4301 / 1.4305 (AISI 304 / 303)
 Stainless Steel V4A **W5**
 1.4401 / 1.4571 (AISI 316 / 316 Ti)

Group	STAUFF	DIN	Dimensions (mm/m)						ØD1	ØD2	Order Codes (Standard Options)	
			Thread G	L1	L2	L3	B	S				H
1	0		M6	58	24,5	44	30	3	6,5	12	6,5	SPV 1 M W2
			1/4-20 UNC	2.28	.96	1.73	1.18	.12	.26	.47	.26	SPV 1 U W2
1A	1		M6	64	20	50	30	3	6,5	12	6,5	SPV 1A M W2
			1/4-20 UNC	2.52	.79	1.97	1.18	.12	.26	.47	.26	SPV 1A U W2
2	2		M6	70	26	56	30	3	6,5	12	6,5	SPV 2 M W2
			1/4-20 UNC	2.76	1.02	2.20	1.18	.12	.26	.47	.26	SPV 2 U W2
3	3		M6	78	33	64	30	3	6,5	12	6,5	SPV 3 M W2
			1/4-20 UNC	3.07	1.30	2.52	1.18	.12	.26	.47	.26	SPV 3 U W2
4	4		M6	87	40	73	30	3	6,5	12	6,5	SPV 4 M W2
			1/4-20 UNC	3.43	1.57	2.87	1.18	.12	.26	.47	.26	SPV 4 U W2
5	5		M6	100	52	86	30	3	6,5	12	6,5	SPV 5 M W2
			1/4-20 UNC	3.94	2.05	3.39	1.18	.12	.26	.47	.26	SPV 5 U W2
6	6		M6	115	66	100	30	3	6,5	12	6,5	SPV 6 M W2
			1/4-20 UNC	4.53	2.60	3.94	1.18	.12	.26	.47	.26	SPV 6 U W2
7	7		M6	150	94	136	30	5	6,5	12	6,5	SPV 7 M W2
			1/4-20 UNC	5.91	3.70	5.35	1.18	.20	.26	.47	.26	SPV 7 U W2
8	8		M6	178	120	162	30	5	6,5	12	6,5	SPV 8 M W2
			1/4-20 UNC	7.01	4.72	6.38	1.18	.20	.26	.47	.26	SPV 8 U W2

All threaded parts are available with Metric ISO thread or unified coarse (UNC) thread according to dimension table. Alternative materials and surface finishings are available upon request. Consult STAUFF for further information.

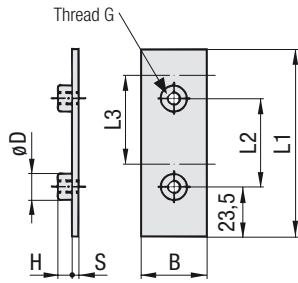

STAUFF Group 1

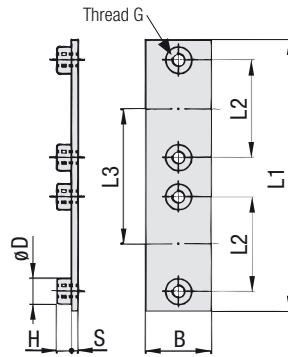

STAUFF Group 1A to 8

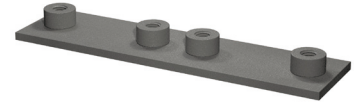
**Twin Weld Plate
Type DSP**

Group STAUFF	DIN	Dimensions (mm/in)								Order Codes (Standard Options)
		Thread G	L1	L2	L3	B	S	H	ØD	
1	0	M6	87	40	40	30	3	6.5	12	DSP 1/40 M W2
		1/4-20 UNC	3.43	1.57	1.57	1.18	.12	.26	.47	DSP 1/40 U W2
1A	1	M6	77	20	37	30	3	6.5	12	DSP 1A/37 M W2
		1/4-20 UNC	3.03	.79	1.46	1.18	.12	.26	.47	DSP 1A/37 U W2
2	2	M6	86	26	44	30	3	6.5	12	DSP 2/44 M W2
		1/4-20 UNC	3.39	1.02	1.73	1.18	.12	.26	.47	DSP 2/44 U W2
3	3	M6	102	33	52	30	3	6.5	12	DSP 3/52 M W2
		1/4-20 UNC	4.02	1.30	2.05	1.18	.12	.26	.47	DSP 3/52 U W2
4	4	M6	120	40	60	30	3	6.5	12	DSP 4/60 M W2
		1/4-20 UNC	4.72	1.57	2.36	1.18	.12	.26	.47	DSP 4/60 U W2
5	5	M6	145	52	75	30	3	6.5	12	DSP 5/75 M W2
		1/4-20 UNC	5.71	2.05	2.95	1.18	.12	.26	.47	DSP 5/75 U W2
6	6	M6	178	66	90	30	3	6.5	12	DSP 6/90 M W2
		1/4-20 UNC	7.01	2.60	3.54	1.18	.12	.26	.47	DSP 6/90 U W2

All threaded parts are available with Metric ISO thread or unified coarse (UNC) thread according to dimension table. Alternative materials and surface finishings are available upon request. Consult STAUFF for further information.

Order Codes
Weld Plate
***DSP*1/40*M*W2**

* Twin Weld Plate		DSP
* STAUFF Group		1
* Pipe center spacing L3 (mm)		40
* Thread code	Metric ISO thread	M
	Unified coarse (UNC) thread	U
* Material code	Carbon Steel, untreated	W1
	Carbon Steel, phosphated	W2
	Carbon Steel, zinc/nickel-plated	W3
	Stainless Steel V2A	W4
	1.4301 / 1.4305 (AISI 304 / 303)	W4
	Stainless Steel V4A	W5
	1.4401 / 1.4571 (AISI 316 / 316 Ti)	W5

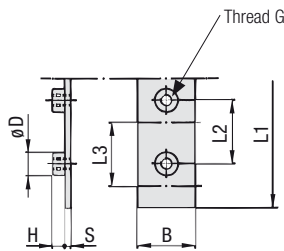

STAUFF Group 1

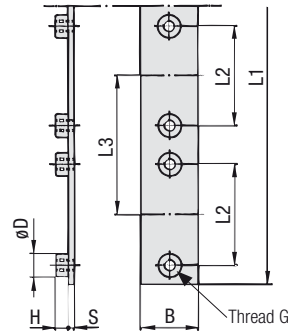

STAUFF Group 1A to 8

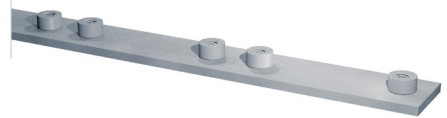
**Group Weld Plate
Type RAP**

Group STAUFF	DIN	Dimensions (mm/in)								Order Codes (Standard Options)
		Thread G	L1	L2	L3	B	S	H	ØD	
1	0	M6	314	31	31	30	4	6.5	12	RAP 1/31/10 M W1
		1/4-20 UNC	12.36	1.22	1.22	1.18	.16	.26	.47	RAP 1/31/10 U W1
1A	1	M6	373	20	37	30	4	6.5	12	RAP 1A/37/10 M W1
		1/4-20 UNC	14.69	.79	1.46	1.18	.16	.26	.47	RAP 1A/37/10 U W1
2	2	M6	442	26	44	30	4	6.5	12	RAP 2/44/10 M W1
		1/4-20 UNC	17.40	1.02	1.73	1.18	.16	.26	.47	RAP 2/44/10 U W1
3	3	M6	521	33	52	30	4	6.5	12	RAP 3/52/10 M W1
		1/4-20 UNC	20.51	1.30	2.05	1.18	.16	.26	.47	RAP 3/52/10 U W1
4	4	M6	300	40	60	30	4	6.5	12	RAP 4/60/5 M W1
		1/4-20 UNC	11.81	1.57	2.36	1.18	.16	.26	.47	RAP 4/60/5 U W1
5	5	M6	378	52	75	30	4	6.5	12	RAP 5/75/5 M W1
		1/4-20 UNC	14.88	2.05	2.95	1.18	.16	.26	.47	RAP 5/75/5 U W1
6	6	M6	450	66	90	30	4	6.5	12	RAP 6/90/5 M W1
		1/4-20 UNC	17.72	2.60	3.54	1.18	.16	.26	.47	RAP 6/90/5 U W1

All threaded parts are available with Metric ISO thread or unified coarse (UNC) thread according to dimension table. Alternative materials and surface finishings are available upon request. Consult STAUFF for further information.

Order Codes
Weld Plate
***RAP*1/31/10*M*W1**

* Group Weld Plate		RAP
* STAUFF Group		1
* Pipe center spacing L3 (mm)		31
* Number of clamps		10
* Thread code	Metric ISO thread	M
	Unified coarse (UNC) thread	U
* Material code	Carbon Steel, untreated	W1
	Carbon Steel, phosphated	W2
	Carbon Steel, zinc/nickel-plated	W3
	Stainless Steel V2A	W4
	1.4301 / 1.4305 (AISI 304 / 303)	W4
	Stainless Steel V4A	W5
	1.4401 / 1.4571 (AISI 316 / 316 Ti)	W5

Angled Weld Plate
Type WSP

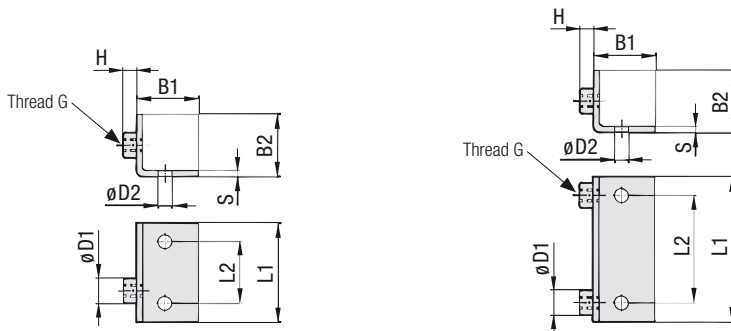

STAUFF Group 1

STAUFF Group 1A to 8

Order Codes

Weld Plate

***WSP*1*M*W1**

- * Angled Weld Plate WSP
- * STAUFF Group 1
- * Thread code Metric ISO thread M
 Unified coarse (UNC) thread U
- * Material code Carbon Steel, untreated W1
 Carbon Steel, zinc/nickel-plated W3

 Stainless Steel V2A W4
 1.4301 / 1.4305 (AISI 304 / 303) W4
 Stainless Steel V4A W5
 1.4401 / 1.4571 (AISI 316 / 316 Ti) W5

Group STAUFF	DIN	Dimensions (mm/m)								Order Codes (Standard Options)	
		Thread G	L1	L2	B1	B2	S	H	ØD1		ØD2
1	0	M6	30	14	30	30	3	6,5	12	6,5	WSP 1 M W1
		1/4-20 UNC	1.18	.55	1.18	1.18	.12	.26	.47	.26	WSP 1 U W1
1A	1	M6	32	20	30	30	3	6,5	12	6,5	WSP 1A M W1
		1/4-20 UNC	1.26	.79	1.18	1.18	.12	.26	.47	.26	WSP 1A U W1
2	2	M6	42	26	30	30	3	6,5	12	6,5	WSP 2 M W1
		1/4-20 UNC	1.65	1.02	1.18	1.18	.12	.26	.47	.26	WSP 2 U W1
3	3	M6	50	33	30	30	3	6,5	12	6,5	WSP 3 M W1
		1/4-20 UNC	1.97	1.30	1.18	1.18	.12	.26	.47	.26	WSP 3 U W1
4	4	M6	60	40	30	30	3	6,5	12	6,5	WSP 4 M W1
		1/4-20 UNC	2.36	1.57	1.18	1.18	.12	.26	.47	.26	WSP 4 U W1
5	5	M6	70	52	30	30	3	6,5	12	6,5	WSP 5 M W1
		1/4-20 UNC	2.76	2.05	1.18	1.18	.12	.26	.47	.26	WSP 5 U W1
6	6	M6	88	66	30	30	3	6,5	12	6,5	WSP 6 M W1
		1/4-20 UNC	3.46	2.60	1.18	1.18	.12	.26	.47	.26	WSP 6 U W1

All threaded parts are available with Metric ISO thread or unified coarse (UNC) thread according to dimension table. Alternative materials and surface finishings are available upon request. Consult STAUFF for further information.

Bridge Weld Plate
Type BSP

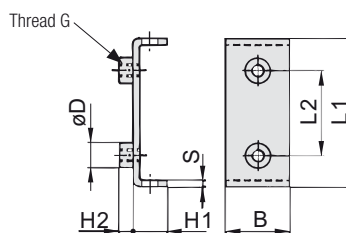
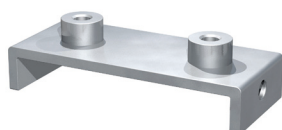

Order Codes

Weld Plate

***BSP*1A*M*W1**

- * Bridge Weld Plate BSP
- * STAUFF Group 1A
- * Thread code Metric ISO thread M
 Unified coarse (UNC) thread U
- * Material code Carbon Steel, untreated W1
 Carbon Steel, zinc/nickel-plated W3

 Stainless Steel V2A W4
 1.4301 / 1.4305 (AISI 304 / 303) W4
 Stainless Steel V4A W5
 1.4401 / 1.4571 (AISI 316 / 316 Ti) W5

Group STAUFF	DIN	Dimensions (mm/m)								Order Codes (Standard Options)
		Thread G	L1	L2	B	S	H1	H2	ØD	
1A	1	M6	48	20	30	3	13	6,5	12	BSP 1A M W1
		1/4-20 UNC	1.89	.79	1.18	1.18	.12	.52	.26	.47
2	2	M6	54	26	30	3	13	6,5	12	BSP 2 M W1
		1/4-20 UNC	2.13	1.02	1.18	1.18	.12	.52	.26	.47
3	3	M6	62	33	30	3	13	6,5	12	BSP 3 M W1
		1/4-20 UNC	2.44	1.30	1.18	1.18	.12	.52	.26	.47
4	4	M6	71	40	30	3	13	6,5	12	BSP 4 M W1
		1/4-20 UNC	2.80	1.57	1.18	1.18	.12	.52	.26	.47
5	5	M6	85	52	30	3	13	6,5	12	BSP 5 M W1
		1/4-20 UNC	3.35	2.05	1.18	1.18	.12	.52	.26	.47
6	6	M6	98	66	30	3	13	6,5	12	BSP 6 M W1
		1/4-20 UNC	3.86	2.60	1.18	1.18	.12	.52	.26	.47

All threaded parts are available with Metric ISO thread or unified coarse (UNC) thread according to dimension table. Alternative materials and surface finishings are available upon request. Consult STAUFF for further information.

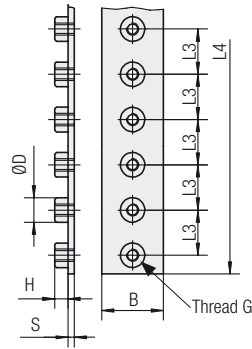

Number of Weld Nuts	Dimensions (mm/in)							Order Codes (Standard Options)
	Thread G	L3	L4	B	S	H	ØD	
6	M6	26	156	30	4	6,5	12	RAP-MGR 25/156 M W1
	1/4-20 UNC	1.02	6.14	1.18	.16	0.26	0.47	RAP-MGR 25/156 U W1
9	M6	26	234	30	4	6,5	12	RAP-MGR 25/234 M W1
	1/4-20 UNC	1.02	9.21	1.18	.16	0.26	0.47	RAP-MGR 25/234 U W1
12	M6	26	312	30	4	6,5	12	RAP-MGR 25/312 M W1
	1/4-20 UNC	1.02	12.28	1.18	.16	0.26	0.47	RAP-MGR 25/312 U W1
15	M6	26	390	30	4	6,5	12	RAP-MGR 25/390 M W1
	1/4-20 UNC	1.02	15.35	1.18	.16	0.26	0.47	RAP-MGR 25/390 U W1
20	M6	26	520	30	4	6,5	12	RAP-MGR 25/520 M W1
	1/4-20 UNC	1.02	20.47	1.18	.16	0.26	0.47	RAP-MGR 25/520 U W1
27	M6	26	700	30	4	6,5	12	RAP-MGR 25/700 M W1
	1/4-20 UNC	1.02	27.55	1.18	.16	0.26	0.47	RAP-MGR 25/700 U W1

Cover a diameter range from 8 mm (.31 in) to 42 mm (1.65 in) with only one Group Weld Plate!

Multi-Group Weld Plates, type RAP-MGR are designed to be used in combination with Standard Series clamp bodies, STAUFF Group 2 (regular types, see pages A6 ff.) covering a diameter range from 8 mm / .31 in to 18 mm / .71 in, as well as Standard Series clamp bodies, STAUFF Group 5 (type MGR, see below) covering a diameter range from 20 mm / .79 in to 42 mm / 1.65 in. Thus, all Standard Series metal parts of these groups can be used.

All threaded parts are available with Metric ISO thread or unified coarse (UNC) thread according to dimension table. Alternative materials and surface finishings are available upon request. Consult STAUFF for further information.

Multi-Group Weld Plate Type RAP-MGR

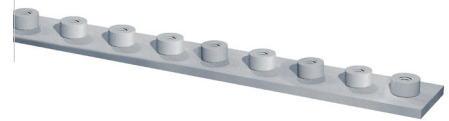
 STAUFF
Clamps
A

Order Codes

Weld Plate *RAP-MGR*25/156*M*W1

* Multi Group Weld Plate	RAP-MGR
* Suitable for STAUFF Group 2 and 5	25
* Length L4 (mm)	156 (with 6 weld nuts) 156 234 (with 9 weld nuts) 234 312 (with 12 weld nuts) 312 390 (with 15 weld nuts) 390 520 (with 20 weld nuts) 520 700 (with 27 weld nuts) 700
* Thread code	Metric ISO thread M Unified coarse (UNC) thread U
* Material code	Carbon Steel, untreated W1 Carbon Steel, phosphated W2 Carbon Steel, zinc/nickel-plated W3 Stainless Steel V2A W4 1.4301 / 1.4305 (AISI 304 / 303) Stainless Steel V4A W5 1.4401 / 1.4571 (AISI 316 / 316 Ti)

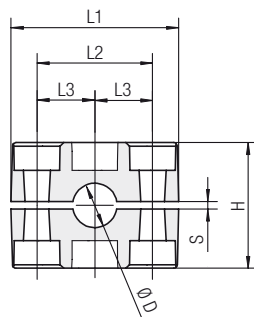

STAUFF Group 5

Group	Outside Diameter Pipe / Tube Ø D	Nominal Bore Pipe Copper Tube	Order Codes (2 Clamp Halves) (** = Material)	Dimensions (mm/in)						
				L1	L2	L3	H	S min.	Width	
5	5	20	520 **-MGR							
		21,3	521,3 **-MGR							
		22	522 **-MGR							
		23	523 **-MGR							
		25	525 **-MGR							
		26,9	526,9 **-MGR							
		28	528 **-MGR	71	52	26	58	0,8	30	
		30	530 **-MGR	2.80	2.05	1.02	2.28	.03	1.18	
		32	532 **-MGR							
		33,7	533,7 **-MGR							
		35	535 **-MGR							
		38	538 **-MGR							
		40	540 **-MGR							
		42	542 **-MGR							

Additional outside diameters are available upon request. Please consult STAUFF for further information.

Clamp Body for Multi-Group Weld Plate Type MGR

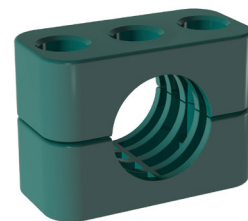

Order Codes

Clamp Body *5*20*PP-MGR

One clamp body is consisting of two clamp halves.

* STAUFF Group	5
* Exact outside diameter Ø D1 (mm)	20
* Material code (see below)	PP-MGR

Standard Materials

Polypropylene
Colour: Green
Material code: PP-MGR

Polyamide
Colour: Black
Material code: PA-MGR

See page A86 for properties and technical information.

Hexagon Rail Nut

Type SM (for Use with Mounting Rail TS)

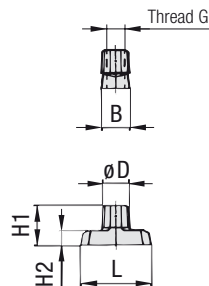
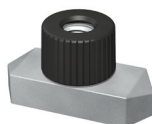

Order Codes

Hexagon Rail Nut *SM*1-8/1D*M*W1

- * Hexagon Rail Nut **SM**
- * STAUFF Group 1 to 8 (DIN Group 0 to 8) **1-8/1D**
- * Thread code Metric ISO thread **M**
Unified coarse (UNC) thread **U**
- * Material code Carbon Steel, untreated **W1**
Carbon Steel, zinc/nickel-plated **W3**
Stainless Steel V2A **W4**
1.4301 / 1.4305 (AISI 304 / 303) **W4**
Stainless Steel V4A **W5**
1.4401 / 1.4571 (AISI 316 / 316 Ti) **W5**

Group STAUFF	DIN	Dimensions (mm/in)						Order Codes (Standard Options)
		Thread G	L	B	H1	H2	ØD	
1	0							
1A	1							
2	2							
3	3							
4	4	M6 1/4-20 UNC	25,5 1.00	10,2 .40	13,5 .53	5,5 .22	12 .47	SM 1-8/1D M W1 SM 1-8/1D U W3 Standard finishing option in North America is W3 (Carbon Steel, zinc/nickel-plated)
5	5							
6	6							
7	7							
8	8							

Hexagon Rail Nuts, type SM 1-8/1D are also suitable for Twin Series, STAUFF Group 1D.

All threaded parts are available with Metric ISO thread or unified coarse (UNC) thread according to dimension table. Alternative materials and surface finishings are available upon request. Consult STAUFF for further information.

Mounting Rail

Type TS (for Use with Hexagon Rail Nut SM)

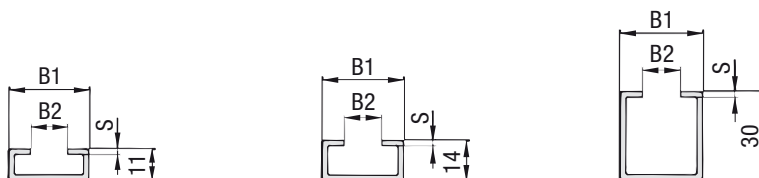
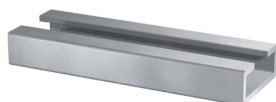

Mounting Rail TS 11

Mounting Rail TS 14

Mounting Rail TS 30

Order Codes

Mounting Rail *TS*11*-1*W1

- * Mounting Rail **TS**
- * Height of rail 11 mm / .43 in **11**
14 mm / .55 in **14**
30 mm / 1.18 in **30**
- * Length of rail 1 m / 3.28 ft **-1**
2 m / 6.56 ft **-2**
Alternative lengths available upon request.
Consult STAUFF for further information.
- * Material code Carbon Steel, untreated **W1**
Carbon Steel, zinc/nickel-plated **W3**
Stainless Steel V2A **W4**
1.4301 / 1.4305 (AISI 304 / 303) **W4**
Stainless Steel V4A **W5**
1.4401 / 1.4571 (AISI 316 / 316 Ti) **W5**

Group STAUFF	DIN	Dimensions (mm/in)			Order Codes (Standard Options)	
		B1	B2	S	Length of Rail: 1 m / 3.28ft	Length of Rail: 2 m / 6.56ft
1	0					
1A	1				Height 11 mm / .43 in TS 11-1 W1	Height 11 mm / .43 in TS 11-2 W1
2	2					
3	3					
4	4	28 1.10	11 .43	2 .08	Height 14 mm / .55 in TS 14-1 W1	Height 14 mm / .55 in TS 14-2 W1
5	5					
6	6					
7	7					
8	8				Height 30 mm / 1.18 in TS 30-1 W1	Height 30 mm / 1.18 in TS 30-2 W1

Mounting Rails, type TS 11/14/30 are suitable for all Standard Series and Twin Series group sizes.

Alternative materials and surface finishings are available upon request. Consult STAUFF for further information.

Channel Rail Adaptor (for Use with Various Channel Rails) Type CRA

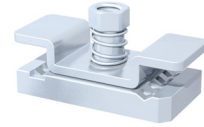
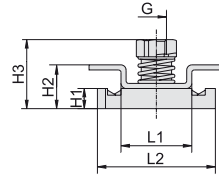
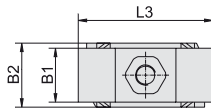

Group STAUFF	DIN	Dimensions (mm/in)									Order Codes (Standard Options)
		Thread G	L1	L2	L3	B1	B2	H1	H2	H3	
1	0										
1A	1										
2	2										
3	3										
4	4	M6	21	35	40	16	19	6	13	20,5	CRA 1-8/1D M W3 CRA 1-8/1D U W3
		1/4-20 UNC	.83	1.38	1.57	.63	.75	.24	.51	.81	
5	5										
6	6										
7	7										
8	8										

Order Codes

Adaptor

***CRA*1-8/1D*M*W3**

* Channel Rail Adaptor	CRA
* STAUFF Group 1 to 8 (DIN Group 0 to 8)	1-8/1D
* Thread code	Metric ISO thread M Unified coarse (UNC) thread U
* Material code	Carbon Steel, zinc/nickel-plated W3 Stainless Steel V4A 1.4401 / 1.4571 (AISI 316 / 316 Ti) W5

The Channel Rail Adaptor, type CRA 1-8/1D is also suitable for Twin Series, STAUFF Group 1D.

All threaded parts are available with Metric ISO thread or unified coarse (UNC) thread according to dimension table. Alternative materials and surface finishings are available upon request. Consult STAUFF for further information.



Compatibility with Channel Rails

The STAUFF Channel Rail Adaptor, type CRA, is suitable for various channel rails, including the following types:

HALFEN	HILTI	UNISTRUT®	STAUFF (Cushion Clamp Series)
HM 41/41	MQ-21, MQ-41, MQ-52, MQ-72	P1000, P1000T, P1000V, P1000VT, P1001	SCS-048-1-PL, SCS-048-1-GR
HZA 41/22	MQ-21U, MQ-41U, MQ-72U	P2000, P2000T	SCS-120-1-PL, SCS-120-1-GR
HZM 41/41	MQ-21D, MQ-41D, MQ-52-72D	P3003, P3003T, P3300V, P3300VT, P3301	See page A83 for technical information.
HZM 41/22		P4000, P4000T	
HL 41/41, HL 41/B2		P5000, P5000T, P5001, P5500, P5500T, P5501	

Consult STAUFF to check compatibility with additional types of channel rails.

Cover Plate
Type DP

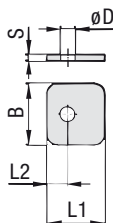

STAUFF Group 1

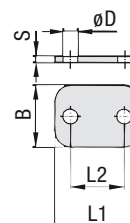

STAUFF Group 1A to 8

Order Codes

Cover Plate

***DP*1*W3**

- * Cover Plate **DP**
- * STAUFF Group **1**
- * Material code Carbon Steel, zinc/nickel-plated **W3**
Stainless Steel V2A **W4**
1.4301 / 1.4305 (AISI 304 / 303)
Stainless Steel V4A **W5**
1.4401 / 1.4571 (AISI 316 / 316 Ti)

Group STAUFF	DIN	Dimensions (mm/in)					Order Codes (Standard Options)
		L1	L2	B	S	ØD	
1	0	28	9,5	30	3	7	DP 1 W3
		1.10	.37	1.18	.12	.28	
1A	1	34	20	30	3	7	DP 1A W3
		1.34	.79	1.18	.12	.28	
2	2	40,5	26	30	3	7	DP 2 W3
		1.59	1.02	1.18	.12	.28	
3	3	48	33	30	3	7	DP 3 W3
		1.89	1.30	1.18	.12	.28	
4	4	57	40	30	3	7	DP 4 W3
		2.24	1.57	1.18	.12	.28	
5	5	70	52	30	3	7	DP 5 W3
		2.76	2.05	1.18	.12	.28	
6	6	86	66	30	3	7	DP 6 W3
		3.39	2.60	1.18	.12	.28	
7	7	118	94	30	5	7	DP 7 W3
		4.65	3.70	1.18	.20	.28	
8	8	144	120	30	5	7	DP 8 W3
		5.67	4.72	1.18	.20	.28	

Alternative materials and surface finishings are available upon request. Consult STAUFF for further information.

Hexagon Head Bolt

Type AS (for Use with Cover Plate DP)

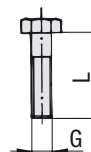

Hexagon Head Bolt AS (according to DIN 931 / 933 or ANSI / ASME B18.2.1.)

Dimensions applicable only when used with Cover Plate DP

Order Codes

Hexagon Head Bolt

***AS*1*M*W3**

- * Type of bolt Hexagon Head Bolt (according to DIN 931 / 933 or ANSI / ASME B18.2.1.) **AS**
- * STAUFF Group **1**
- * Thread code Metric ISO thread **M**
Unified coarse (UNC) thread **U**
- * Material code Carbon Steel, zinc/nickel-plated **W3**
Stainless Steel V2A **W4**
1.4301 / 1.4305 (AISI 304 / 303)
Stainless Steel V4A **W5**
1.4401 / 1.4571 (AISI 316 / 316 Ti)

Group STAUFF	DIN	Dimensions (mm/in)		Order Codes (Standard Options)
		Thread	G x L	
1	0	M6 x 30		AS 1 M W3
		1/4-20 UNC x 1-1/4		AS 1 U W3
1A	1	M6 x 30		AS 1A M W3
		1/4-20 UNC x 1-1/4		AS 1A U W3
2	2	M6 x 35		AS 2 M W3
		1/4-20 UNC x 1-3/8		AS 2 U W3
3	3	M6 x 40		AS 3 M W3
		1/4-20 UNC x 1-1/2		AS 3 U W3
4	4	M6 x 45		AS 4 M W3
		1/4-20 UNC x 1-7/8		AS 4 U W3
5	5	M6 x 60		AS 5 M W3
		1/4-20 UNC x 2-3/8		AS 5 U W3
6	6	M6 x 70		AS 6 M W3
		1/4-20 UNC x 2-3/4		AS 6 U W3
7	7	M6 x 100		AS 7 M W3
		1/4-20 UNC x 4		AS 7 U W3
8	8	M6 x 125		AS 8 M W3
		1/4-20 UNC x 4-7/8		AS 8 U W3

All threaded parts are available with Metric ISO thread or unified coarse (UNC) thread according to dimension table. Alternative materials and surface finishings are available upon request. Consult STAUFF for further information.

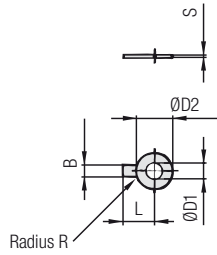
**Safety Washer
Type SI (DIN 93)**

Safety Washer SI (according to DIN 93)

Group STAUFF	DIN	Dimensions (mm/in)						Order Codes (Standard Options)
		ØD1	B	ØD2	L	R	S	
1 to 8	0 to 8	6,4	7	19	18	4	0,5	SI 6,4 DIN 93 W3
		.25	.28	.75	.71	.16	.02	

Safety Washers, type SI are used as locking devices to prevent Hexagon Head Bolts, type AS from loosening.
Safety Washers, type SI are suitable for all Standard Series group sizes.

Alternative materials and surface finishings are available upon request. Consult STAUFF for further information.

Order Codes
Safety Washer *SI*6,4*DIN 93*W3

* Type of washer Safety washer with 1 tab (according to DIN 93) **SI 6,4 DIN 93**

* Material code Carbon Steel, zinc/nickel-plated **W3**

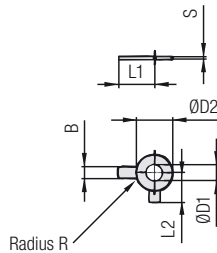
**Safety Washer
Type SI (DIN 463)**

Safety Washer SI (according to DIN 463)

Group STAUFF	DIN	Dimensions (mm/in)						Order Codes (Standard Options)	
		ØD1	B	ØD2	L1	L2	R		S
1 to 8	0 to 8	6,4	7	12	18	9	4	0,5	SI 6,4 DIN 463 W3
		.25	.28	.47	.71	.35	.16	.02	

Safety Washers, type SI are used as locking devices to prevent Hexagon Head Bolts, type AS from loosening.
Safety Washers, type SI are suitable for all Standard Series group sizes.

Alternative materials and surface finishings are available upon request. Consult STAUFF for further information.

Order Codes
Safety Washer *SI*6,4*DIN 463*W3

* Type of washer Safety washer with 2 tabs (according to DIN 463) **SI 6,4 DIN 463**

* Material code Carbon Steel, zinc/nickel-plated **W3**

Socket Cap Screw Type IS **Slotted Head Screw Type LI**
(with Washer)

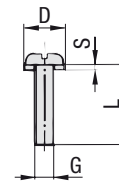
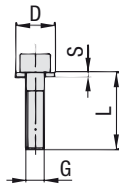
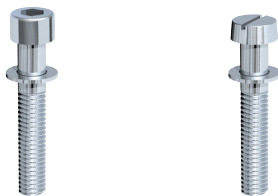

Socket Cap Screw IS

(according to ISO 4762 or ANSI / ASME B18.3)

Dimensions applicable only when used without Cover Plate DP

Slotted Head Screw LI

(according to ISO 1207 or ANSI / ASME B18.6.3)

Dimensions applicable only when used without Cover Plate DP

Order Codes

Socket Cap Screw

***IS*1*M*W3**

Slotted Head Screw

***LI*1*M*W3**

- * Type of bolt Socket Cap Screw with Washer (according to ISO 4762 or ANSI / ASME B18.3) **IS**
- Slotted Head Screw with Washer (according to ISO 1207 or ANSI / ASME B18.6.3) **LI**
- * STAUFF Group **1**
- * Thread code Metric ISO thread **M**
- Unified coarse (UNC) thread **U**
- * Material code Carbon Steel, zinc/nickel-plated **W3**
- Stainless Steel V2A **W4**
- 1.4301 / 1.4305 (AISI 304 / 303) **W4**
- Stainless Steel V4A **W5**
- 1.4401 / 1.4571 (AISI 316 / 316 Ti)

Group STAUFF	DIN	Dimensions (mm/in)			Order Codes (Standard Options)	
		Thread G x L	D	S	Socket Cap Screws	Slotted Head Screws
1	0	M6 x 20			IS 1 M W3	LI 1 M W3
		1/4-20 UNC x 3/4			IS 1 U W3	LI 1 U W3
1A	1	M6 x 20			IS 1A M W3	LI 1A M W3
		1/4-20 UNC x 3/4			IS 1A U W3	LI 1A U W3
2	2	M6 x 25			IS 2 M W3	LI 2 M W3
		1/4-20 UNC x 1			IS 2 U W3	LI 2 U W3
3	3	M6 x 30			IS 3 M W3	LI 3 M W3
		1/4-20 UNC x 1-1/8			IS 3 U W3	LI 3 U W3
4	4	M6 x 35	11	0,8	IS 4 M W3	LI 4 M W3
		1/4-20 UNC x 1-3/8	.43		IS 4 U W3	LI 4 U W3
5	5	M6 x 50			IS 5 M W3	LI 5 M W3
		1/4-20 UNC x 2			IS 5 U W3	LI 5 U W3
6	6	M6 x 60			IS 6 M W3	LI 6 M W3
		1/4-20 UNC x 2-1/2			IS 6 U W3	LI 6 U W3
7	7	M6 x 90			IS 7 M W3	ON REQUEST ONLY
		1/4-20 UNC x 3-3/8			IS 7 U W3	
8	8	M6 x 110			IS 8 M W3	ON REQUEST ONLY
		1/4-20 UNC x 4-3/8			IS 8 U W3	

All threaded parts are available with Metric ISO thread or unified coarse (UNC) thread according to dimension table. Alternative materials and surface finishings are available upon request. Consult STAUFF for further information.

Hexagon Head Bolt Type ASE

Insert Type ES / EP

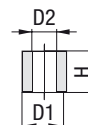
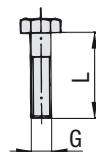
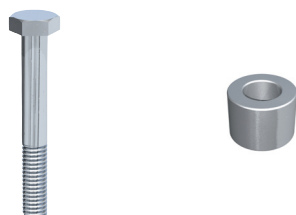

Hexagon Head Bolt ASE

(according to DIN 931 / 933 or ANSI / ASME B18.2.1.)

Dimensions applicable only when used with Inserts EP / ES

Inserts ES (Steel) / EP (Plastic)

Order Codes

Hexagon Head Bolt

***ASE*1*M*W3**

- * Type of bolt Hexagon Head Bolt (according to DIN 931 / 933 or ANSI / ASME B18.2.1.) **AS**
- for use with Insert ES / EP **E**
- * STAUFF Group **1**
- * Thread code Metric ISO thread **M**
- Unified coarse (UNC) thread **U**
- * Material code Carbon Steel, zinc/nickel-plated **W3**
- Stainless Steel V2A **W4**
- 1.4301 / 1.4305 (AISI 304 / 303) **W4**
- Stainless Steel V4A **W5**
- 1.4401 / 1.4571 (AISI 316 / 316 Ti)

Group STAUFF	DIN	Dimensions (mm/in)		Order Codes (Standard Options)	
		Thread G x L	D	S	
1	0	M6 x 27			ASE 1 M W3
		1/4-20 UNC x 1-1/8			ASE 1 U W3
1A	1	M6 x 27			ASE 1A M W3
		1/4-20 UNC x 1-1/8			ASE 1A U W3
2	2	M6 x 32			ASE 2 M W3
		1/4-20 UNC x 1-3/8			ASE 2 U W3
3	3	M6 x 35			ASE 3 M W3
		1/4-20 UNC x 1-3/8			ASE 3 U W3
4	4	M6 x 42			ASE 4 M W3
		1/4-20 UNC x 1-5/8			ASE 4 U W3
5	5	M6 x 57			ASE 5 M W3
		1/4-20 UNC x 2-3/8			ASE 5 U W3
6	6	M6 x 65			ASE 6 M W3
		1/4-20 UNC x 2-3/4			ASE 6 U W3
7	7	M6 x 95			ASE 7 M W3
		1/4-20 UNC x 4			ASE 7 U W3
8	8	M6 x 118			ASE 8 M W3
		1/4-20 UNC x 4-3/4			ASE 8 U W3

Group STAUFF	DIN	Dimensions (mm/in)				Order Codes (Standard Options)	
		D1	D2	H ES	H EP	ES (Steel)	EP (Plastic)
1 to 8	0 to 8	11,8	6,5	7,8	8,6	ES	EP
		.46	.26	.31	.34		

All threaded parts are available with Metric ISO thread or unified coarse (UNC) thread according to dimension table. Alternative materials and surface finishings are available upon request. Consult STAUFF for further information.

Safety Locking Plate (for Use with Stacking Bolt AF) Type SIG

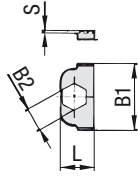

STAUFF Group 1

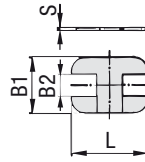

STAUFF Group 1A to 8

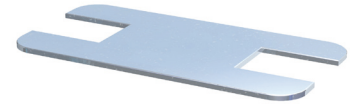

Group STAUFF	DIN	Dimensions (mm/in)				Order Codes (Standard Options)
		L	B1	B2	S	
1	0	16	32	11,2	1	SIG 1 W3
		0.63	1.26	.44	.04	
1A	1	33	28	11,2	1	SIG 1A W3
		1.30	1.10	.44	.04	
2	2	39	28	11,2	1	SIG 2 W3
		1.54	1.10	.44	.04	
3	3	47	28	11,2	1	SIG 3 W3
		1.85	1.10	.44	.04	
4	4	56	28	11,2	1	SIG 4 W3
		2.20	1.10	.44	.04	
5	5	69	28	11,2	1	SIG 5 W3
		2.72	1.10	.44	.04	
6	6	85	28	11,2	1	SIG 6 W3
		3.35	1.10	.44	.04	
7	7	117	28	11,2	1	SIG 7 W3
		4.61	1.10	.44	.04	
8	8	143	28	11,2	1	SIG 8 W3
		5.63	1.10	.44	.04	

Order Codes

Safety Locking Plate

***SIG*1*W3**

* Safety Locking Plate		SIG
* STAUFF Group		1
* Material code	Carbon Steel, zinc/nickel-plated	W3
	Stainless Steel V2A	W4
	1.4301 / 1.4305 (AISI 304 / 303)	
	Stainless Steel V4A	W5
	1.4401 / 1.4571 (AISI 316 / 316 Ti)	

Alternative materials and surface finishings are available upon request. Consult STAUFF for further information.

Stacking Bolt (for Use with Safety Locking Plate SIG) Type AF

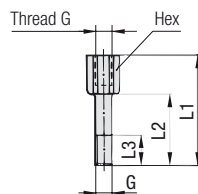

Group STAUFF	DIN	Dimensions (mm/in)					Order Codes (Standard Options)
		Thread G	L1	L2	L3 min.	Hex	
1	0	M6	34	20	12	11	AF 1 M W3
		1/4-20 UNC	1.34	.79	.47	.43	AF 1 U W3
1A	1	M6	34	20	12	11	AF 1A M W3
		1/4-20 UNC	1.34	.79	.47	.43	AF 1A U W3
2	2	M6	40	25	12	11	AF 2 M W3
		1/4-20 UNC	1.57	.98	.47	.43	AF 2 U W3
3	3	M6	44	30	12	11	AF 3 M W3
		1/4-20 UNC	1.73	1.18	.47	.43	AF 3 U W3
4	4	M6	49	35	12	11	AF 4 M W3
		1/4-20 UNC	1.93	1.38	.47	.43	AF 4 U W3
5	5	M6	64	50	12	11	AF 5 M W3
		1/4-20 UNC	2.52	1.97	.47	.43	AF 5 U W3
6	6	M6	74	60	12	11	AF 6 M W3
		1/4-20 UNC	2.91	2.36	.47	.43	AF 6 U W3
7	7	M6	99	85	12	11	AF 7 M W3
		1/4-20 UNC	3.90	3.35	.47	.43	AF 7 U W3
8	8	M6	124	110	12	11	AF 8 M W3
		1/4-20 UNC	4.88	4.33	.47	.43	AF 8 U W3

Order Codes

Stacking Bolt

***AF*1*M*W3**

* Type of bolt	Stacking Bolt (according to STAUFF Standard)	AF
* STAUFF Group		1
* Thread code	Metric ISO thread	M
	Unified coarse (UNC) thread	U
* Material code	Carbon Steel, zinc/nickel-plated	W3
	Stainless Steel V2A	W4
	1.4301 / 1.4305 (AISI 304 / 303)	
	Stainless Steel V4A	W5
	1.4401 / 1.4571 (AISI 316 / 316 Ti)	

All threaded parts are available with Metric ISO thread or unified coarse (UNC) thread according to dimension table. Alternative materials and surface finishings are available upon request. Consult STAUFF for further information.



① Type of Installation

Please select the type of installation (e.g. Weld Plates, Rail Nuts, etc.) and add the corresponding Code to position ① of the order code for your clamp assembly.

Without Installation Equipment
Code: **none**

Installation on Weld Plate

Single Weld Plate
Code: **SP**

Elongated Weld Plate
Code: **SPV**

Twin Weld Plate (for STAUFF Group 1 to 6 only)
Code: **DSP**

Group Weld Plate (for STAUFF Group 1 to 6 only)
Code: **RAP**

Angled Weld Plate (for STAUFF Group 1 to 6 only)
Code: **WSP**

Bridge Weld Plate (for STAUFF Group 1A to 6 only)
Code: **BSP**

Installation on Mounting / Channel Rail

Hexagon Rail Nut
Code: **SM**

Channel Rail Adaptor
Code: **CRA**

② Group Size & Diameter

Please select the required group size and diameter and add the corresponding Code to position ② of the order code for your clamp assembly.

Group STAUFF (DIN)	Outside Diameter P / T / H (mm)	Availability of Clamp Body Materials & Designs Profiled			Code
		Design	Type H	Type RI	
1 (0)	6	●	●	○	106
	6,4	●	●	○	106,4
	8	●	●	○	108
	9,5	●	●	○	109,5
	10	●	●	○	110
1A (1)	12	●	●	○	112
	6	●	●	○	106A
	6,4	●	●	○	106,4A
	8	●	●	○	108A
	9,5	●	●	○	109,5A
2 (2)	10	●	●	○	110A
	12	●	●	○	112A
	12,7	●	●	○	212,7
	13,5	●	●	○	213,5
	14	●	●	○	214
	15	●	●	○	215
	16	●	●	○	216
3 (3)	17,2	●	●	○	217,2
	18	●	●	○	218
	13,4	○	●	○	313,4
	17,4	○	●	○	317,4
	19	●	●	○	319
	20	●	●	○	320
	20,5	○	●	○	320,5
4 (4)	21,3	●	●	○	321,3
	22	●	●	○	322
	23,9	○	●	○	323,9
	25	●	●	○	325
	25,4	●	●	○	325,4
	6	○	○	●	406
	8	○	○	●	408
	10	○	○	●	410
	12	○	○	●	412
	12,7	○	○	●	412,7
14	○	○	●	414	
15	○	○	●	415	
16	○	○	●	416	
17,2	○	○	●	417,2	
18	○	○	●	418	
19	○	○	●	419	
26,9	●	●	○	426,9	
28	●	●	○	428	
28,6	●	○	○	428,6	
30	●	●	○	430	
32	●	●	○	432	

Group STAUFF (DIN)	Outside Diameter P / T / H (mm)	Availability of Clamp Body Materials & Designs Profiled			Code
		Design	Type H	Type RI	
5 (5)	27,8	○	●	○	527,8
	32	●	●	○	532
	33,7	●	●	○	533,7
	35	●	●	○	535
	35,7	○	●	○	535,7
	38	●	●	○	538
	40	●	●	○	540
	41,3	●	○	○	541,3
	42	●	●	○	542
	43,8	○	●	○	543,8
6 (6)	20	○	○	●	620
	21,3	○	○	●	621,3
	22	○	○	●	622
	25	○	○	●	625
	26,9	○	○	●	626,9
	28	○	○	●	628
	30	○	○	●	630
	32	○	○	●	632
	44,5	●	●	○	644,5
	48,3	●	●	○	648,3
7 (7)	49,8	○	●	○	649,8
	50,8	●	●	○	650,8
	54	●	●	○	654
	57,2	●	●	○	757,2
	60,3	●	●	○	760,3
	63,5	●	●	○	763,5
8 (8)	70	●	●	○	770
	73	●	●	○	773
	76,1	●	●	○	776,1
8 (8)	88,9	●	●	○	888,9
	102	●	●	○	8102L

● Standard Option

Additional outside diameters are available upon request. Please consult STAUFF for further information.

Please see pages A22 and A23 with detailed order examples for some of the most popular Standard Series clamp assemblies.

③ Clamp Body Design & Material

Please select the design and material of your clamp body and add the corresponding Code to position ③ of the order code for your clamp assembly.

Please check the availability of the selected clamp body design and material according to the matrix table in ②.

Profiled Design



Polypropylene
Code: **PP**



Polyamide
Code: **PA**



Thermoplastic Elastomer (87 Shore-A)
Code: **SA**



Aluminium
Code: **AL** (for STAUFF Group 1A to 6 only)

Type H (Smooth)



Polypropylene
Code: **PPH**



Polyamide
Code: **PAH**



Thermoplastic Elastomer (87 Shore-A)
Code: **SAH**

Type RI (with Rubber Insert)



Polypropylene
Code: **PPR** (for STAUFF Group 4 and 6 only)



Polyamide
Code: **PAR** (for STAUFF Group 4 and 6 only)

See page A86 for material properties and technical information.

Please consult STAUFF for further details on fire-proof and corrosion preventing clamp body materials, tested and approved according to several international fire-protection standards.

④ Mounting & Fitting Combination

Please select the mounting and fitting combination (e.g. bolts, screws, cover plates, etc.) and add the corresponding Code to position ④ of the order code for your clamp assembly.

Installation with Cover Plate and Bolts

Cover Plate DP with
Hexagon Head Bolts AS
Code: **DP-AS**

Cover Plate DP with
Socket Cap Screws IS
Code: **DP-IS**

Installation with Locking Plate and Bolts

Safety Locking Plate SIG with
Stacking Bolts AF
Code: **SIG-AF**

Installation with Inserts and Bolts

Inserts EP (Plastic) with
Hexagon Head Bolts ASE
Code: **EP-AS**

Inserts ES (Steel) with
Hexagon Head Bolts ASE
Code: **ES-AS**

Installation with Bolts only

Socket Cap Screws IS with Washers
Code: **IS**

Slotted Head Screws LI with Washers
Code: **LI** (for STAUFF Group 1 to 6 only)

⑤ Thread Type

Please select the required thread type and add the corresponding Code to position ⑤ of the order code for your clamp assembly.

Metric ISO thread
Code: **M**

Unified coarse (UNC) thread
Code: **U**

All threaded parts are available with Metric ISO thread or unified coarse (UNC) thread according to dimension table.

⑥ Material & Surface Finishing

Please select the required material & surface finishing of the metal parts and add the corresponding Code to position ⑥ of the order code for your clamp assembly.

Metal parts made of Carbon Steel, untreated **W1**

Metal parts made of Carbon Steel, phosphated **W2**

Metal parts made of Carbon Steel, zinc/nickel-plated **W3**

Metal parts made of Stainless Steel V2A
1.4301 / 1.4305 (AISI 304 / 303) **W4**

Metal parts made of Stainless Steel V4A
1.4401 / 1.4571 (AISI 316 / 316 Ti) **W5**

Weld Plate made of Carbon Steel, phosphated; Other metal parts made of Carbon Steel, zinc/nickel-plated **W10**

Rail Nuts made of Carbon Steel, untreated; Other metal parts made of Carbon Steel, zinc/nickel-plated **W11**

Individual combinations of alternative materials and surface finishings are available upon request. Consult STAUFF for further information.

⑦ Assembling & Kitting

If required, please select an additional assembling and kitting option and add the corresponding Code to the last position of the order code for your clamp assembly.

Components supplied separately

Code: **none** (standard option)

Components assembled

Code: **#A** (special option)

Components packed in kits

Code: **#K** (special option)



- 2x **Hexagon Head Bolt**
Surface: W3
Thread: Metric
- 1x **Cover Plate**
Surface: W3
- 1x **Clamp Body** (two halves)
STAUFF Group 2 (DIN 2)
O.D. 12,7 mm / .50 in
Material: Polypropylene
Profiled inside surface
with tension clearance
- 1x **Single Weld Plate**
Surface: W2
Thread: Metric

Order Code**SP 212,7 PP DP-AS M W10**

W10 is the standard option for this type of installation.



- 2x **Socket Cap Screw**
Surface: W3
Thread: Metric
- 1x **Clamp Body** (two halves)
STAUFF Group 2 (DIN 2)
O.D. 12,7 mm / .50 in
Material: Polypropylene
Profiled inside surface
with tension clearance
- 1x **Single Weld Plate**
Surface: W2
Thread: Metric

Order Code**SP 212,7 PP IS M W10**

W10 is the standard option for this type of installation.

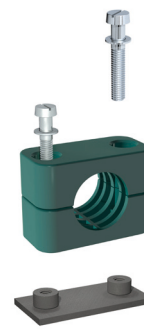

- 2x **Slotted Head Screw**
Surface: W3
Thread: Metric
- 1x **Clamp Body** (two halves)
STAUFF Group 2 (DIN 2)
O.D. 12,7 mm / .50 in
Material: Polypropylene
Profiled inside surface
with tension clearance
- 1x **Single Weld Plate**
Surface: W2
Thread: Metric

Order Code**SP 212,7 PP LI M W10**

W10 is the standard option for this type of installation.
Available up to STAUFF Group 6 (DIN Group 6) only.



- 2x **Hexagon Head Bolt**
Surface: W3
Thread: Metric
- 1x **Cover Plate**
Surface: W3
- 1x **Clamp Body** (two halves)
STAUFF Group 2 (DIN 2)
O.D. 12,7 mm / .50 in
Material: Polypropylene
Profiled inside surface
with tension clearance
- 1x **Elongated Weld Plate**
Surface: W2
Thread: Metric

Order Code**SPV 212,7 PP DP-AS M W10**

W10 is the standard option for this type of installation.



- 2x **Socket Cap Screw**
Surface: W3
Thread: Metric
- 1x **Clamp Body** (two halves)
STAUFF Group 2 (DIN 2)
O.D. 12,7 mm / .50 in
Material: Polypropylene
Profiled inside surface
with tension clearance
- 1x **Elongated Weld Plate**
Surface: W2
Thread: Metric

Order Code**SPV 212,7 PP IS M W10**

W10 is the standard option for this type of installation.



- 2x **Slotted Head Screw**
Surface: W3
Thread: Metric
- 1x **Clamp Body** (two halves)
STAUFF Group 2 (DIN 2)
O.D. 12,7 mm / .50 in
Material: Polypropylene
Profiled inside surface
with tension clearance
- 1x **Elongated Weld Plate**
Surface: W2
Thread: Metric

Order Code**SPV 212,7 PP LI M W10**

W10 is the standard option for this type of installation.
Available up to STAUFF Group 6 (DIN Group 6) only.



- 2x **Hexagon Head Bolt**
Surface: W3
Thread: Metric
- 1x **Cover Plate**
Surface: W3
- 1x **Clamp Body** (two halves)
STAUFF Group 2 (DIN 2)
O.D. 12,7 mm / .50 in
Material: Polypropylene
Profiled inside surface
with tension clearance
- 2x **Hexagon Rail Nut**
Surface: W1
Thread: Metric

Order Code (Mounting Rail TS not included.)**SM 212,7 PP DP-AS M W11**

W11 is the standard option for this type of installation.



- 2x **Socket Cap Screw**
Surface: W3
Thread: Metric
- 1x **Clamp Body** (two halves)
STAUFF Group 2 (DIN 2)
O.D. 12,7 mm / .50 in
Material: Polypropylene
Profiled inside surface
with tension clearance
- 2x **Hexagon Rail Nut**
Surface: W1
Thread: Metric

Order Code (Mounting Rail TS not included.)**SM 212,7 PP IS M W11**

W11 is the standard option for this type of installation.



- 2x **Slotted Head Screw**
Surface: W3
Thread: Metric
- 1x **Clamp Body** (two halves)
STAUFF Group 2 (DIN 2)
O.D. 12,7 mm / .50 in
Material: Polypropylene
Profiled inside surface
with tension clearance
- 2x **Hexagon Rail Nut**
Surface: W1
Thread: Metric

Order Code (Mounting Rail TS not included.)**SM 212,7 PP LI M W11**

W11 is the standard option for this type of installation.
Available up to STAUFF Group 6 (DIN Group 6) only.



- 2x **Hexagon Head Bolt**
Surface: W3
Thread: Metric
- 1x **Cover Plate**
Surface: W3
- 1x **Clamp Body** (two halves)
STAUFF Group 2 (DIN 2)
O.D. 12,7 mm / .50 in
Material: Polypropylene
Profiled inside surface
with tension clearance

Order Code

212,7 PP DP-AS M W3

W3 is the standard option for this type of installation.



- 2x **Socket Cap Screw**
Surface: W3
Thread: Metric
- 1x **Clamp Body** (two halves)
STAUFF Group 2 (DIN 2)
O.D. 12,7 mm / .50 in
Material: Polypropylene
Profiled inside surface
with tension clearance

Order Code

212,7 PP IS M W3

W3 is the standard option for this type of installation.



- 2x **Slotted Head Screw**
Surface: W3
Thread: Metric
- 1x **Clamp Body** (two halves)
STAUFF Group 2 (DIN 2)
Tube-O.D. 12,7 mm / .50 in
Material: Polypropylene
Profiled inside surface
with tension clearance

Order Code

212,7 PP LI M W3

W3 is the standard option for this type of installation.



- 2x **Stacking Bolt**
Surface: W3
Thread: Metric
- 1x **Safety Locking Plate**
Surface: W3
- 1x **Clamp Body** (two halves)
STAUFF Group 2 (DIN 2)
O.D. 12,7 mm / .50 in
Material: Polypropylene
Profiled inside surface
with tension clearance

Order Code

212,7 PP SIG-AF M W3

W3 is the standard option for this type of installation.



- 1x **Socket Cap Screw**
Surface: W3
Thread: Metric
- 1x **Clamp Body** (two halves)
STAUFF Group 1 (DIN 0)
O.D. 6 mm / .24 in
Material: Polypropylene
Profiled inside surface
with tension clearance
Thread: Metric
- 1x **Single Weld Plate**
Surface: W2
Thread: Metric

Order Code*

SP 106 PP IS M W10

W10 is the standard option for this type of installation.

Thread codes

All threaded parts are available with Metric ISO thread or unified coarse (UNC) thread according to dimension table.

Metric ISO thread	M
Unified coarse (UNC) thread	U

Material codes

The below listed material codes describe the materials and surface finishings of metal parts that are most relevant for Standard Series clamp assemblies. Individual combinations of alternative materials and surface finishings are available upon request. Consult STAUFF for further information.

Metal parts made of Carbon Steel, untreated	W1
Metal parts made of Carbon Steel, phosphated	W2
Metal parts made of Carbon Steel, zinc/nickel-plated	W3
Metal parts made of Stainless Steel V2A	W4
1.4301 / 1.4305 (AISI 304 / 303)	W4
Metal parts made of Stainless Steel V4A	W5
1.4401 / 1.4571 (AISI 316 / 316 Ti)	W5
Weld Plate made of Carbon Steel, phosphated; Other metal parts made of Carbon Steel, zinc/nickel-plated	W10
Rail Nuts made of Carbon Steel, untreated; Other metal parts made of Carbon Steel, zinc/nickel-plated	W11

Technical Notes

* Because of their design, STAUFF Group 1 (DIN Group 0) clamp assemblies only include a single bolt / screw.

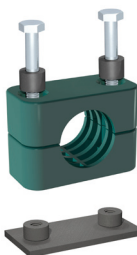

- 2x **Hexagon Head Bolt**
Surface: W3
Thread: Metric
- 2x **Insert**
Material: Plastic
- 1x **Clamp Body** (two halves)
STAUFF Group 2 (DIN 2)
O.D. 12,7 mm / .50 in
Material: Polypropylene
Profiled inside surface
with tension clearance
- 1x **Single Weld Plate**
Surface: W2
Thread: Metric

Order Code

SP 212,7 PP EP-AS M W10

W10 is the standard option for this type of installation.

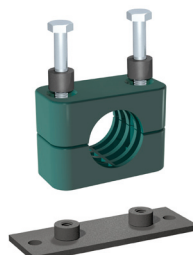

- 2x **Hexagon Head Bolt**
Surface: W3
Thread: Metric
- 2x **Insert**
Material: Plastic
- 1x **Clamp Body** (two halves)
STAUFF Group 2 (DIN 2)
O.D. 12,7 mm / .50 in
Material: Polypropylene
Profiled inside surface
with tension clearance
- 1x **Elongated Weld Plate**
Surface: W2
Thread: Metric

Order Code

SPV 212,7 PP EP-AS M W10

W10 is the standard option for this type of installation.

Clamp Body - Profiled Design

Profiled Inside Surface with Tension Clearance

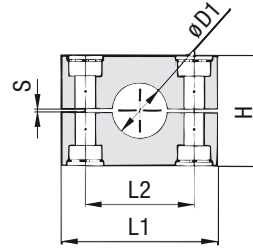
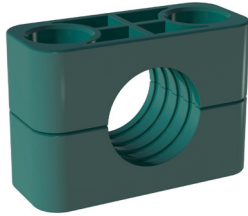

Order Codes

Clamp Body

***3*006*PP**

One clamp body is consisting of two clamp halves.

- * 1st part of STAUFF Group **3**
- * Exact outside diameter Ø D1 (mm) **006**
- * Material code (see below) **PP**

Standard Materials



Polypropylene
Colour: Green
Material code: **PP**



Polyamide
Colour: Black
Material code: **PA**



Thermoplastic Elastomer (87 Shore-A)
Colour: Black
Material code: **SA**



Aluminium
Colour: Self-Colour
Material code: **AL**

See page A86 for material properties and technical information.

Special Materials

Please consult STAUFF for further details on fire-proof and corrosion preventing clamp body materials, tested and approved according to several international fire-protection standards.

See page A87 for material properties and technical information.

Product Features

- .. Proven, tested and trusted product in various markets
- .. Recommended for the safe installation of rigid pipes and tubes
- .. Available for all commonly used pipe and tube outside diameters
- .. Environmental protection due to vibration/noise reducing design
- .. Excellent weathering resistance, even under extreme conditions

Group	STAUFF	DIN	Outside Diameter		Nominal Bore		Order Codes (2 Clamp Halves) (** = Material)	Dimensions (mm/in)							
			Pipe / Tube Ø D1 (mm)	(in)	Pipe (in)	Copper Tube (in)		L1 PP/PA/SA	L1 AL	L2	H	S min.	Width		
3S	1	6					3006 **								
		6,4	1/4				3006,4 **								
		8	5/16				3008 **								
		9,5	3/8		1/4		3009,5 **								
		10		1/8			3010 **								
		12					3012 **								
		12,7	1/2		3/8		3012,7 **	55	56	33	32	0,6	30,5		
		13,5		1/4			3013,5 **	2.16	2.20	1.30	1.26	.02	1.20		
		14					3014 **								
		15					3015 **								
		16	5/8		1/2		3016 **								
		17,2		3/8			3017,2 **								
18					3018 **										
20					3020 **										
4S	2	19	3/4				4019 **								
		20					4020 **								
		21,3		1/2			4021,3 **								
		22			3/4		4022 **								
		25					4025 **	70	70	45	48	0,6	30,5		
		25,4	1				4025,4 **	2.76	2.76	1.77	1.89	.02	1.20		
		26,9		3/4			4026,9 **								
		28					4028 **								
		30					4030 **								
		30					5030 **								
5S	3	32	1-1/4				5032 **								
		33,7		1			5033,7 **								
		35			1-1/4		5035 **	85	85	60	60	0,6	30,5		
		38	1-1/2				5038 **	3.35	3.35	2.36	2.36	.02	1.20		
		40					5040 **								
		41,3			1-1/2		5041,3 **								
		42		1-1/4			5042 **								
6S	4	38	1-1/2				6038 **								
		42		0			6042 **								
		44,5	1-3/4				6044,5 **								
		48,3		1-1/2			6048,3 **								
		50,8	2				6050,8 **								
		54			2		6054 **	115	120	90	89	2	45		
		55					6055 **	4.53	4.72	3.54	3.50	.08	1.77		
		57					6057 **								
		57,2	2-1/4				6057,2 **								
		60,3		2			6060,3 **								
63,5	2-1/2				6063,5 **										
65					6065 **										
70	2-3/4				6070 **										

See page A25 for STAUFF Group 7S to 12S (DIN Group 5 to 10).

Additional outside diameters are available upon request. Please consult STAUFF for further information.

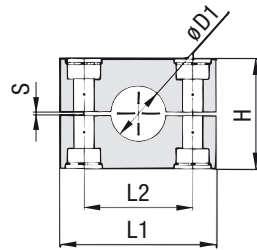

Clamp Body - Profiled Design

Profiled Inside Surface with Tension Clearance

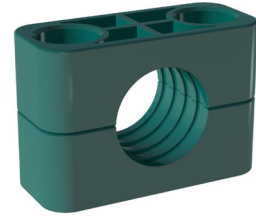

Group	STAUFF	DIN	Outside Diameter		Nominal Bore	Order Codes (2 Clamp Halves) (** = Material)	Dimensions (mm/in)					
			Pipe / Tube Ø D1 (mm)	(in)			Pipe (in)	L1 PP/PA	L1 AL	L2	H	S min.
7S	5	60,3			7060,3 **	154	152	122	120	2	60	
		65			7065 **							
		70	2-3/4		7070 **							
		73		2-1/2 (ANSI B 36-10)	7073 **							
		75			7075 **							
		76,1	3	2-1/2 (DIN EN 10220)	7076,1 **							
		80			7080 **							
		82,5			7082,5 **							
8S	6	88,9	3-1/2	3	8088,9 **	206	208	168	168	2	80	
		100			8100 **							
		102	4	3-1/2	8102 **							
		108			8108 **							
		114	4-1/2	4	8114 **							
		127	5		8127 **							
		133			8133 **							
		9S	7	127	5							
133					9133 **							
140				5	9140 **							
152	6				9152 **							
159					9159 **							
165					9165 **							
168				6	9168 **							
10S	8			168		6	10168 **	336	326	265	270	3
		177,8			10177,8 **							
		193,7			10193,7 **							
		203	8		10203 **							
		216			10216 **							
11S	9	219		8	11219 **	470	470	395	410	8	162	
		273		10	11273 **							
		324		12	11324 **							
12S	10	356		14	12356 **	630	630	534	530	20	182	
		406		16	12406 **							

Order Codes

Clamp Body

***7*060,3*PP**

One clamp body is consisting of two clamp halves.

- * 1st part of STAUFF Group
- * Exact outside diameter Ø D1 (mm)
- * Material code (see below)

**7
060,3
PP**

Standard Materials



Polypropylene
Colour: Green
Material code: **PP**



Polyamide
Colour: Black
Material code: **PA**



Aluminium
Colour: Self-Colour
Material code: **AL**

See page A86 for material properties and technical information.

Special Materials

Please consult STAUFF for further details on fire-proof and corrosion preventing clamp body materials, tested and approved according to several international fire-protection standards.

See page A87 for material properties and technical information.

Product Features

- Proven, tested and trusted product in various markets
- Recommended for the safe installation of rigid pipes and tubes
- Available for all commonly used pipe and tube outside diameters
- Environmental protection due to vibration/noise reducing design
- Excellent weathering resistance, even under extreme conditions

See page A24 for STAUFF Group 3S to 6S (DIN Group 1 to 4).

Additional outside diameters are available upon request. Please consult STAUFF for further information.

Clamp Body ▪ Type H

Smooth Inside Surface without Tension Clearance

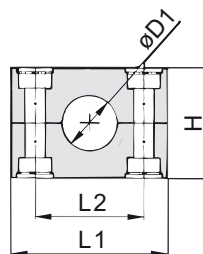
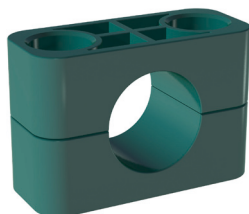

Order Codes

Clamp Body

***3*006*PPH**

One clamp body is consisting of two clamp halves.

- * 1st part of STAUFF Group **3**
- * Exact outside diameter $\varnothing D1$ (mm) **006**
- * Material code (see below) **PPH**

Standard Materials



Polypropylene
Colour: Green
Material code: **PPH**



Polyamide
Colour: Black
Material code: **PAH**



Thermoplastic Elastomer (87 Shore-A)
Colour: Black
Material code: **SAH**

See page A86 for material properties and technical information.

Special Materials

Please consult STAUFF for further details on fire-proof and corrosion preventing clamp body materials, tested and approved according to several international fire-protection standards.

See page A87 for material properties and technical information.

Product Features

- .. Proven, tested and trusted product in various markets
- .. Recommended for the safe installation of hoses and cables
- .. Chamfered edges avoid damaging of the hose or cable
- .. Available for all commonly used hose and cable outside diameters
- .. Excellent weathering resistance, even under extreme conditions

Group	STAUFF	DIN	Outside Diameter		Nominal Bore Hydraulic Hose SAE 100 R2 AT (in)	Order Codes (2 Clamp Halves) (** = Material)	Dimensions (mm/in)			
			$\varnothing D1$ (mm)	(in)			L1	L2	H	Width
3S	1	6				3006 ***	55 2.16	33 1.30	30,5 1.20	30,5 1.20
		6,4	1/4			3006,4 ***				
		8	5/16			3008 ***				
		9,5	3/8			3009,5 ***				
		10				3010 ***				
		12				3012 ***				
		12,7	1/2			3012,7 ***				
		13,5				3013,5 ***				
		14				3014 ***				
		15		1/4		3015 ***				
		16	5/8			3016 ***				
		17,2				3017,2 ***				
		18				3018 ***				
		4S	2	15		1/4				
19	3/4					4019 ***				
19,8				3/8		4019,8 ***				
20						4020 ***				
21,3						4021,3 ***				
22						4022 ***				
22,1				1/2		4022,1 ***				
25						4025 ***				
25,1				5/8		4025,1 ***				
25,4	1					4025,4 ***				
26,9						4026,9 ***				
28						4028 ***				
29,2				3/4		4029,2 ***				
30						4030 ***				
5S	3	30				5030 ***	85 3.35	60 2.36	58 2.28	30,5 1.20
		32	1-1/4			5032 ***				
		33,7				5033,7 ***				
		35				5035 ***				
		38	1-1/2			5038 ***				
		40				5040 ***				
		41,3				5041,3 ***				
		42				5042 ***				
6S	4	37,8		1		6037,8 ***	115 4.53	90 3.54	87 3.43	45 1.77
		38	1-1/2			6038 ***				
		42				6042 ***				
		44,5	1-3/4			6044,5 ***				
		48,3				6048,3 ***				
		48,4		1-1/4		6048,4 ***				
		50,8	2			6050,8 ***				
		54,4		1-1/2		6054,4 ***				
		55				6055 ***				
		57				6057 ***				
		57,2	2-1/4			6057,2 ***				
		60,3				6060,3 ***				
		63,5	2-1/2			6063,5 ***				
		65				6065 ***				
70	2-3/4			6070 ***						

Additional outside diameters are available upon request. Please consult STAUFF for further information.

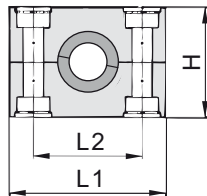
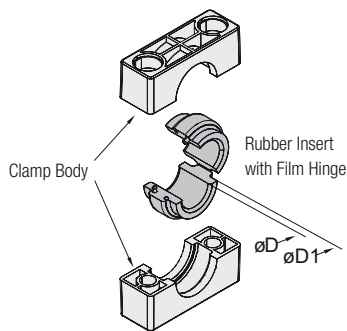

Clamp Body with Rubber Insert Type RI



Group	STAUFF	DIN	Outside Diameter		Order Codes (**R = Clamp Body Material)			Dimensions								
			Pipe / Tube / Hose	Ø D	Clamp Assembly (Clamp Body + Rubber Insert)	Clamp Body (2 Clamp Halves)	Rubber Insert *	(mm/in)	Ø D1	L1	L2	H	Width			
4S	2	6		4006 **R	4S **R	RI 06 (4+4S)	25	70	45	46,5	30,5	.98	2.76	1.77	4.83	1.20
		8	5/16	4008 **R		RI 08 (4+4S)										
		10		4010 **R		RI 10 (4+4S)										
		12		4012 **R		RI 12 (4+4S)										
		12,7	1/2	4012,7 **R		RI 12,7 (4+4S)										
		14		4014 **R		RI 14 (4+4S)										
		15		4015 **R		RI 15 (4+4S)										
		16	5/8	4016 **R		RI 16 (4+4S)										
		17,2		4017,2 **R		RI 17,2 (4+4S)										
		18		4018 **R		RI 18 (4+4S)										
19	3/4	4019 **R	RI 19 (4+4S)													
5S	3	20		5020 **R	5S **R	RI 20 (6+5S)	38	85	60	58	30,5	1.50	3.35	2.36	2.28	1.20
		21,3		5021,3 **R		RI 21,3 (6+5S)										
		22	7/8	5022 **R		RI 22 (6+5S)										
		25		5025 **R		RI 25 (6+5S)										
		26,9		5026,9 **R		RI 26,9 (6+5S)										
		28		5028 **R		RI 28 (6+5S)										
		30		5030 **R		RI 30 (6+5S)										
		32	1-1/4	5032 **R		RI 32 (6+5S)										
		32	1-1/4	6032 **R		RI 32 (6S)										
		33,7		6033,7 **R		RI 33,7 (6S)										
35		6035 **R	RI 35 (6S)													
38,7		6038,7 **R	RI 38,7 (6S)													
40		6040 **R	RI 40 (6S)													
42		6042 **R	RI 42 (6S)													
45,5		6045,5 **R	RI 45,5 (6S)													
48		6048 **R	RI 48 (6S)													
51	2	6051 **R	RI 51 (6S)													
53,4		6053,4 **R	RI 53,4 (6S)													
56,4		6056,4 **R	RI 56,4 (6S)													
7S	5	55		7055 **R	7S **R	RI 55 (7S)	88	154	122	120	60	3.56	6.06	4.80	4.72	2.36
		57	2-1/4	7057 **R		RI 57 (7S)										
		60		7060 **R		RI 60 (7S)										
		63,5	2-1/2	7063,5 **R		RI 63,5 (7S)										
		65		7065 **R		RI 65 (7S)										
		70	2-3/4	7070 **R		RI 70 (7S)										
		72		7072 **R		RI 72 (7S)										
		76	3	7076 **R		RI 76 (7S)										
8S	6	80		8080 **R	8S **R	RI 80 (8S)	114	208	168	168	80	4.49	8.11	6.61	6.61	3.15
		88,9	3-1/2	8088,9 **R		RI 88,9 (8S)										
		102		8102 **R		RI 102 (8S)										
		114		9114 **R		RI 114 (9S)										
9S	7	133	5-1/4	9133 **R	9S **R	RI 133 (9S)	150	251	205	200	91	5.91	9.88	8.07	7.87	3.58
		140		9140 **R		RI 140 (9S)										
		150		10150 **R		RI 150 (10S)										
10S	8	165		10165 **R	10S **R	RI 165 (10S)	200	336	265	270	120	7.87	13.22	10.43	10.63	4.72
		168		10168 **R		RI 168 (10S)										
		172		10172 **R		RI 172 (10S)										

Order Codes

Clamp Assembly *4*006*PPR

One assembly is consisting of one clamp body and one insert.

- * 1st part of STAUFF Group **4**
- * Exact outside diameter Ø D (mm) **006**
- * Material code (see below) **PPR**

Clamp Body *4S*PPR

One clamp body is consisting of two clamp halves.

- * STAUFF Group **4S**
- * Material code (see below) **PPR**

Rubber Insert *RI*06*(4+4S)

- * Rubber Insert **RI**
- * Exact outside diameter Ø D (mm) **06**
- * STAUFF Group 4S (Heavy) and 4 (Standard) **(4+4S)**
- 5S (Heavy) and 6 (Standard) **(6+5S)**
- 6S (Heavy) **(6S)**
- 7S (Heavy) **(7S)**
- 8S (Heavy) **(8S)**
- 9S (Heavy) **(9S)**
- 10S (Heavy) **(10S)**

Standard Materials

Polypropylene
Colour: Black
Material code: **PPR**

Polyamide
Colour: Black
Material code: **PAR**

Rubber Insert
4S to 6S: **Thermoplastic Elastomer** (73 Shore-A)
7S to 10S: **Elastomer** (70 Shore-A)
Colour: Black

See page A86 for properties and technical information.

Special Materials

Please consult STAUFF for further details on fire-proof and corrosion preventing clamp body materials, tested and approved according to several international fire-protection standards.

See page A87 for properties and technical information.

Product Features

- Proven, tested and trusted product in various markets
- Either for the extra vibration/noise reducing installation of pipes and tubes or the extra gentle installation of hoses and cables
- Available for all commonly used outside diameters
- Excellent weathering resistance, even under extreme conditions

* Rubber Inserts for Heavy Series clamp bodies, STAUFF Group 4S also fit into Standard Series clamp bodies, STAUFF Group 4.
Rubber Inserts for Heavy Series clamp bodies, STAUFF Group 5S also fit into Standard Series clamp bodies, STAUFF Group 6.

Additional outside diameters are available upon request. Please consult STAUFF for further information.

Weld Plate for Single Clamps
Type SPAL

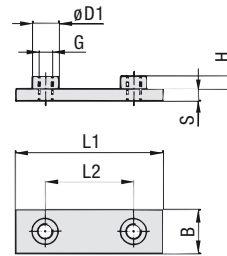
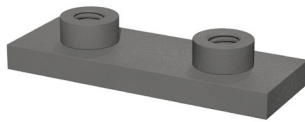

Order Codes

Weld Plate

***SPAL*3S*M*W2**

- * Weld Plate for Single Clamps **SPAL**
- * STAUFF Group **3S**
- * Thread code Metric ISO thread **M**
 Unified coarse (UNC) thread **U**
- * Material code Carbon Steel, untreated **W1**
 Carbon Steel, phosphated **W2**
 Carbon Steel, zinc/nickel-plated **W3**

 Stainless Steel V2A **W4**
 1.4301 / 1.4305 (AISI 304 / 303)
 Stainless Steel V4A **W5**
 1.4401 / 1.4571 (AISI 316 / 316 Ti)

Group	STAUFF	DIN	Dimensions (mm/m)					Thread G	ØD1	Order Codes (Standard Options)
			L1	L2	B	S	H			
3S	1		74	33	30	8	8	M10	18	SPAL 3S M W2
			2.91	1.30	1.18	.31	.31	3/8-16 UNC	.71	SPAL 3S U W2
4S	2		86	45	30	8	8	M10	18	SPAL 4S M W2
			3.39	1.77	1.18	.31	.31	3/8-16 UNC	.71	SPAL 4S U W2
5S	3		100	60	30	8	8	M10	18	SPAL 5S M W2
			3.94	2.36	1.18	.31	.31	3/8-16 UNC	.71	SPAL 5S U W2
6S	4		140	90	45	10	8	M12	20	SPAL 6S M W2
			5.51	3.54	1.77	.39	.31	7/16-14 UNC	.78	SPAL 6S U W2
7S	5		180	122	60	10	12	M16	24	SPAL 7S M W2
			7.09	4.80	2.36	.39	.47	5/8-11 UNC	.94	SPAL 7S U W2
8S	6		226	168	80	15	18	M20	30	SPAL 8S M W1
			8.90	6.61	3.15	.59	.71	3/4-10 UNC	1.18	SPAL 8S U W1
9S	7		270	205	90	15	21	M24	35	SPAL 9S M W1
			10.63	8.07	3.54	.59	.83	7/8-9 UNC	1.38	SPAL 9S U W1
10S	8		340	265	120	25	21	M30	45	SPAL 10S M W1
			13.39	10.43	4.72	.98	.83	1-1/8-7 UNC	1.77	SPAL 10S U W1
11S	9		520	395	160	30	38	M30	50	SPAL 11S M W1
			20.47	15.55	6.30	1.18	1.50	1-1/4-7 UNC	1.97	SPAL 11S U W1
12S	10		680	534	180	30	38	M30	50	SPAL 12S M W1
			27.16	21.02	7.09	1.18	1.50	1-1/4-7 UNC	1.97	SPAL 12S U W1

All threaded parts are available with Metric ISO thread or unified coarse (UNC) thread according to dimension table. Alternative materials and surface finishings are available upon request. Consult STAUFF for further information.

Weld Plate for Double Clamps
Type SPAS

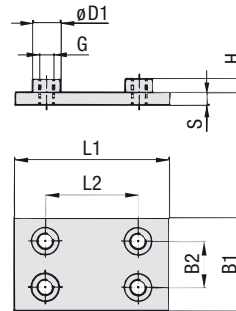
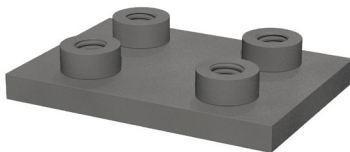

Order Codes

Weld Plate

***SPAS*3S*M*W2**

- * Weld Plate for Double Clamps **SPAS**
- * STAUFF Group **3S**
- * Thread code Metric ISO thread **M**
 Unified coarse (UNC) thread **U**
- * Material code Carbon Steel, untreated **W1**
 Carbon Steel, phosphated **W2**
 Carbon Steel, zinc/nickel-plated **W3**

 Stainless Steel V2A **W4**
 1.4301 / 1.4305 (AISI 304 / 303)
 Stainless Steel V4A **W5**
 1.4401 / 1.4571 (AISI 316 / 316 Ti)

Group	STAUFF	DIN	Dimensions (mm/m)					Thread G	ØD1	Order Codes (Standard Options)	
			L1	L2	B1	B2	S				H
3S	1		74	33	60	30,5	8	8	M10	18	SPAS 3S M W2
			2.91	1.30	2.36	1.20	.31	.31	3/8-16 UNC	.71	SPAS 3S U W2
4S	2		86	45	60	30,5	8	8	M10	18	SPAS 4S M W2
			3.39	1.77	2.36	1.20	.31	.31	3/8-16 UNC	.71	SPAS 4S U W2
5S	3		100	60	60	30,5	8	8	M10	18	SPAS 5S M W2
			3.94	2.36	2.36	1.20	.31	.31	3/8-16 UNC	.71	SPAS 5S U W2
6S	4		140	90	90	46	10	8	M12	20	SPAS 6S M W2
			5.51	3.54	3.54	1.81	.39	.31	7/16-14 UNC	.78	SPAS 6S U W2
7S	5		180	122	120	61	10	12	M16	24	SPAS 7S M W2
			7.09	4.80	4.72	2.40	.39	.47	5/8-11 UNC	.94	SPAS 7S U W2
8S	6		226	168	160	81	15	18	M20	30	SPAS 8S M W1
			8.90	6.61	6.61	3.19	.59	.71	3/4-10 UNC	1.18	SPAS 8S U W1
9S	7		270	205	180	91	15	21	M24	35	SPAS 9S M W1
			10.63	8.07	7.09	3.58	.59	.83	7/8-9 UNC	1.38	SPAS 9S U W1
10S	8		340	265	240	121	25	21	M30	45	SPAS 10S M W1
			13.39	10.43	9.45	4.78	.98	.83	1-1/8-7 UNC	1.77	SPAS 10S U W1
11S	9		520	395	324	166	30	38	M30	50	SPAS 11S M W1
			20.47	15.55	12.76	6.54	1.18	1.50	1-1/4-7 UNC	1.97	SPAS 11S U W1
12S	10		680	534	364	186	30	38	M30	50	SPAS 12S M W1
			27.16	21.02	14.33	7.32	1.18	1.50	1-1/4-7 UNC	1.97	SPAS 12S U W1

All threaded parts are available with Metric ISO thread or unified coarse (UNC) thread according to dimension table. Alternative materials and surface finishings are available upon request. Consult STAUFF for further information.

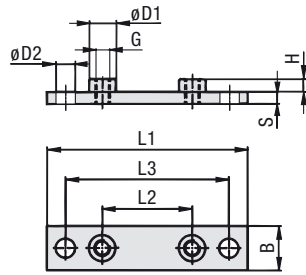

Elongated Weld Plate for Single Clamps Type SPAL/DUEB

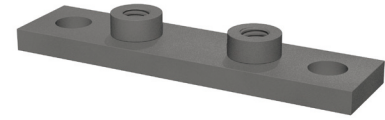
 STAUFF
Clamps
A

Group STAUFF	DIN	Dimensions (mm/m)									Order Codes (Standard Options)	
		L1	L2	L3	B	S	H	Thread G	ØD1	ØD2		
3S	1	113	33	85	30	8	8	M10	18	13	SPAL/DUEB 3S M W2	
		4.45	1.30	3.35	1.18	.31	.31	3/8-16 UNC	.71	.51	SPAL/DUEB 3S U W2	
4S	2	125	45	97	30	8	8	M10	18	13	SPAL/DUEB 4S M W2	
		4.92	1.77	3.82	1.18	.31	.31	3/8-16 UNC	.71	.51	SPAL/DUEB 4S U W2	
5S	3	140	60	112	30	8	8	M10	18	13	SPAL/DUEB 5S M W2	
		5.51	2.36	4.41	1.18	.31	.31	3/8-16 UNC	.71	.51	SPAL/DUEB 5S U W2	
6S	4	187	90	155	45	10	8	M12	20	16	SPAL/DUEB 6S M W2	
		7.36	3.54	6.10	1.77	.39	.31	7/16-14 UNC	.78	.62	SPAL/DUEB 6S U W2	
7S	5	238	122	198	60	10	12	M16	24	21	SPAL/DUEB 7S M W2	
		9.37	4.80	7.80	2.36	.39	.47	5/8-11 UNC	.94	.83	SPAL/DUEB 7S U W2	
8S	6	309	168	259	80	15	18	M20	30	26	SPAL/DUEB 8S M W1	
		12.17	6.61	10.20	3.15	.59	.71	3/4-10 UNC	1.18	1.02	SPAL/DUEB 8S U W1	
9S	7	370	205	310	90	15	21	M24	35	31	SPAL/DUEB 9S M W1	
		14.57	8.07	12.20	3.54	.59	.83	7/8-9 UNC	1.38	1.22	SPAL/DUEB 9S U W1	
10S	8	440	265	380	120	25	21	M30	45	31	SPAL/DUEB 10S M W1	
		17.32	10.43	14.96	4.72	.98	.83	1-1/8-7 UNC	1.77	1.22	SPAL/DUEB 10S U W1	
11S	9	590	395	530	160	30	38	M30	50	31	SPAL/DUEB 11S M W1	
		23.23	15.55	20.87	6.30	1.18	1.50	1-1/4-7 UNC	1.97	1.22	SPAL/DUEB 11S U W1	
12S	10	750	534	690	180	30	38	M30	50	31	SPAL/DUEB 12S M W1	
		29.53	21.02	27.17	7.09	1.18	1.50	1-1/4-7 UNC	1.97	1.22	SPAL/DUEB 12S U W1	

Order Codes

Weld Plate *SPAL/DUEB*3S*M*W2

- * Elongated Weld Plate for Single Clamps **SPAL/DUEB**
- * STAUFF Group **3S**
- * Thread code Metric ISO thread **M**
Unified coarse (UNC) thread **U**
- * Material code Carbon Steel, untreated **W1**
Carbon Steel, phosphated **W2**
Carbon Steel, zinc/nickel-plated **W3**
Stainless Steel V2A **W4**
1.4301 / 1.4305 (AISI 304 / 303) **W4**
Stainless Steel V4A **W5**
1.4401 / 1.4571 (AISI 316 / 316 Ti) **W5**

All threaded parts are available with Metric ISO thread or unified coarse (UNC) thread according to dimension table. Alternative materials and surface finishings are available upon request. Consult STAUFF for further information.

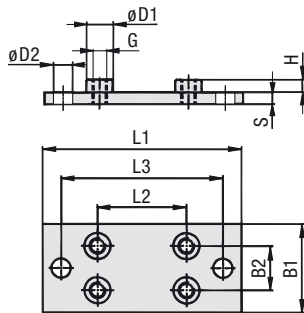

STAUFF Group 3S to 9S

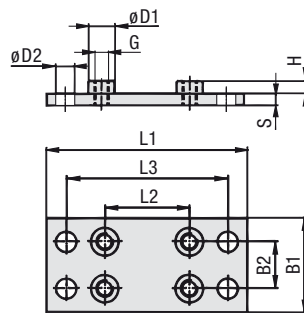

STAUFF Group 10S to 12S

Elongated Weld Plate for Double Clamps Type SPAS/DUEB

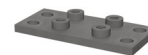
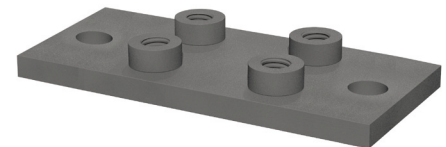

Design for STAUFF Group 10S to 12S

Group STAUFF	DIN	Dimensions (mm/m)										Order Codes (Standard Options)	
		L1	L2	L3	B1	B2	S	H	Thread G	ØD1	ØD2		
3S	1	113	33	85	60	30,5	8	8	M10	18	13	SPAS/DUEB 3S M W2	
		4.45	1.30	3.35	2.36	1.20	.31	.31	3/8-16 UNC	.71	.51	SPAS/DUEB 3S U W2	
4S	2	125	45	97	60	30,5	8	8	M10	18	13	SPAS/DUEB 4S M W2	
		4.92	1.77	3.82	2.36	1.20	.31	.31	3/8-16 UNC	.71	.51	SPAS/DUEB 4S U W2	
5S	3	140	60	112	60	30,5	8	8	M10	18	13	SPAS/DUEB 5S M W2	
		5.51	2.36	4.41	2.36	1.20	.31	.31	3/8-16 UNC	.71	.51	SPAS/DUEB 5S U W2	
6S	4	187	90	155	90	46	10	8	M12	20	16	SPAS/DUEB 6S M W2	
		7.36	3.54	6.10	3.54	1.81	.39	.31	7/16-14 UNC	.78	.62	SPAS/DUEB 6S U W2	
7S	5	238	122	198	120	61	10	12	M16	24	21	SPAS/DUEB 7S M W2	
		9.37	4.80	7.80	4.72	2.40	.39	.47	5/8-11 UNC	.94	.83	SPAS/DUEB 7S U W2	
8S	6	309	168	259	160	81	15	18	M20	30	26	SPAS/DUEB 8S M W1	
		12.17	6.61	10.20	6.61	3.19	.59	.71	3/4-10 UNC	1.18	1.02	SPAS/DUEB 8S U W1	
9S	7	370	205	310	180	91	15	21	M24	35	31	SPAS/DUEB 9S M W1	
		14.57	8.07	12.20	7.09	3.58	.59	.83	7/8-9 UNC	1.38	1.22	SPAS/DUEB 9S U W1	
10S	8	440	265	380	240	121	25	21	M30	45	31	SPAS/DUEB 10S M W1	
		17.32	10.43	14.96	9.45	4.78	.98	.83	1-1/8-7 UNC	1.77	1.22	SPAS/DUEB 10S U W1	
11S	9	590	395	530	324	166	30	38	M30	50	31	SPAS/DUEB 11S M W1	
		23.23	15.55	20.87	12.76	6.54	1.18	1.50	1-1/4-7 UNC	1.97	1.22	SPAS/DUEB 11S U W1	
12S	10	750	534	690	364	186	30	38	M30	50	31	SPAS/DUEB 12S M W1	
		29.53	21.02	27.17	14.33	7.32	1.18	1.50	1-1/4-7 UNC	1.97	1.22	SPAS/DUEB 12S U W1	

Order Codes

Weld Plate *SPAS/DUEB*3S*M*W2

- * Elongated Weld Plate for Double Clamps **SPAS/DUEB**
- * STAUFF Group **3S**
- * Thread code Metric ISO thread **M**
Unified coarse (UNC) thread **U**
- * Material code Carbon Steel, untreated **W1**
Carbon Steel, phosphated **W2**
Carbon Steel, zinc/nickel-plated **W3**
Stainless Steel V2A **W4**
1.4301 / 1.4305 (AISI 304 / 303) **W4**
Stainless Steel V4A **W5**
1.4401 / 1.4571 (AISI 316 / 316 Ti) **W5**

All threaded parts are available with Metric ISO thread or unified coarse (UNC) thread according to dimension table. Alternative materials and surface finishings are available upon request. Consult STAUFF for further information.

Mounting Rail Nut

Type **GMV** (for Use with Mounting Rail STSV)

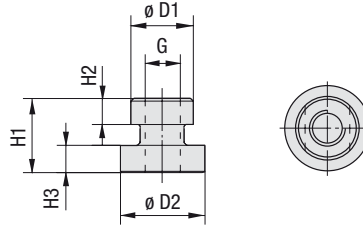

Order Codes

Mounting Rail Nut ***GMV*3-5S*M*W3**

- * Mounting Rail Nut **GMV**
- * STAUFF Group 3S to 5S (DIN Group 1 to 3) **3-5S**
6S (DIN Group 4) **6S**
- * Thread code Metric ISO thread **M**
Unified coarse (UNC) thread **U**
- * Material code Carbon Steel, zinc/nickel-plated **W3**
Stainless Steel V2A **W4**
1.4301 / 1.4305 (AISI 304 / 303)
Stainless Steel V4A **W5**
1.4401 / 1.4571 (AISI 316 / 316 Ti)

Group STAUFF	DIN	Dimensions (mm / in)					Thread G	Order Codes (Standard Options)
		ØD1	ØD2	H1	H2	H3		
3S	1							
4S	2	17,8 .70	24 .94	21 .83	7,6 .30	7,4 .29	M10 3/8-16 UNC	GMV 3-5S M W3 GMV 3-5S U W3
5S	3							
6S	4	19,8 .78	24 .94	23 .91	8,8 .35	8,2 .32	M12 7/16-14 UNC	GMV 6S M W3 GMV 6S U W3

All threaded parts are available with Metric ISO thread or unified coarse (UNC) thread according to dimension table. Alternative materials and surface finishings are available upon request. Consult STAUFF for further information.

Mounting Rail

Type **STSV** (for Use with Mounting Rail Nut GMV)

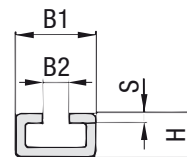

Order Codes

Mounting Rail ***STSV*1*W1**

- * Mounting Rail **STSV**
- * Length of rail 1 m / 3.28 ft **1**
2 m / 6.56 ft **2**
Alternative lengths available upon request. Consult STAUFF for further information.
- * Material code Carbon Steel, untreated **W1**
Carbon Steel, zinc/nickel-plated **W3**
Stainless Steel V4A **W5**
1.4401 / 1.4571 (AISI 316 / 316 Ti)

Group STAUFF	DIN	Dimensions (mm / in)				Order Codes (Standard Options)	
		B1	B2	H	S	Length of Rail: 1 m / 3.28ft	Length of Rail: 2 m / 6.56ft
3S	1						
4S	2	40	13	22	5	STSV 1 W1	STSV 2 W1
5S	3	1.57	.39	.86	.19		
6S	4						

Alternative materials and surface finishings are available upon request. Consult STAUFF for further information.

Channel Rail Adaptor (for Use with Various Channel Rails) Type CRA

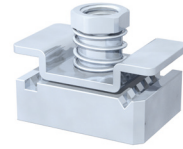
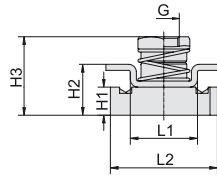
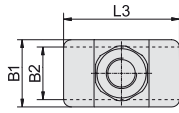

Group STAUFF	DIN	Dimensions (mm/m)									Order Codes (Standard Options)	
		Thread G	L1	L2	L3	B1	B2	H1	H2	H3		
3S	1											
4S	2	M10	22	35	38	22	20,5	9,2	16,7	27,5	CRA 3-5S M W3 CRA 3-5S U W3	
		3/8-16 UNC	.87	1.38	1.50	.87	.81	.36	.66	1.08		
5S	3											
6S	4	M12	21,5	35	45	25	19	9,2	15,2	27,5	CRA 6S M W3 CRA 6S U W3	
		7/16-14 UNC	.85	1.38	1.77	.98	.75	.36	.60	1.08		

Order Codes

Adaptor

***CRA*3-5S*M*W3**

* Channel Rail Adaptor	CRA
* STAUFF Group	3S to 5S (DIN Group 1 to 3) 6S (DIN Group 4)
* Thread code	Metric ISO thread Unified coarse (UNC) thread
* Material code	Carbon Steel, zinc/nickel-plated Stainless Steel V4A 1.4401 / 1.4571 (AISI 316 / 316 Ti)

All threaded parts are available with Metric ISO thread or unified coarse (UNC) thread according to dimension table. Alternative materials and surface finishings are available upon request. Consult STAUFF for further information.



Compatibility with Channel Rails

The STAUFF Channel Rail Adaptor, type CRA is suitable for various channel rails, including the following types:

HALFEN	HILTI	UNISTRUT®	STAUFF (Cushion Clamp Series)
HM 41/41	MQ-21, MQ-41, MQ-52, MQ-72	P1000, P1000T, P1000V, P1000VT, P1001	SCS-048-1-PL, SCS-048-1-GR
HZA 41/22	MQ-21U, MQ-41U, MQ-72U	P2000, P2000T	SCS-120-1-PL, SCS-120-1-GR
HZM 41/41	MQ-21D, MQ-41D, MQ-52-72D	P3003, P3003T, P3300V, P3300VT, P3301	See page A83 for technical information.
HZM 41/22		P4000, P4000T	
HL 41/41, HL 41/B2		P5000, P5000T, P5001, P5500, P5500T, P5501	

Consult STAUFF to check compatibility with additional types of channel rails.

Recommended Bolt Lengths when using the Channel Rail Adaptor, Type CRA

Group STAUFF	DIN	Hexagon Head Bolts AS (used with Cover Plates DPAL or DPAS)		Socket Cap Screws IS (used without Cover Plates DPAL or DPAS)	
		Metric ISO thread	Unified coarse (UNC) thread	Metric ISO thread	Unified coarse (UNC) thread
3S	1	M10 x 40	3/8-16 UNC x 1-1/2	M10 x 25	3/8-16 UNC x 1
4S	2	M10 x 55	3/8-16 UNC x 2-1/4	M10 x 40	3/8-16 UNC x 1-1/2
5S	3	M10 x 65	3/8-16 UNC x 2-3/4	M10 x 50	3/8-16 UNC x 2
6S	4	M12 x 100	7/16-14 UNC x 3-3/4	M12 x 75	7/16-14 UNC x 3

Clamp assemblies including Channel Rail Adaptors, type CRA are supplied with the recommended bolt lengths by default. See page A37 for further information on ordering.

**Cover Plate for Single Clamps
Type DPAL**

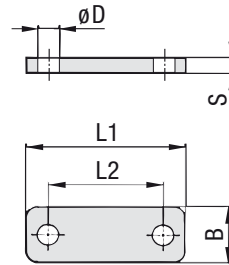

Order Codes

Cover Plate

***DPAL*3S*W2**

- * Cover Plate for Single Clamps **DPAL**
- * STAUFF Group **3S**
- * Material code
 - Carbon Steel, untreated **W1**
 - Carbon Steel, phosphated **W2**
 - Carbon Steel, zinc/nickel-plated **W3**
 - Stainless Steel V2A **W4**
 - 1.4301 / 1.4305 (AISI 304 / 303) **W4**
 - Stainless Steel V4A **W5**
 - 1.4401 / 1.4571 (AISI 316 / 316 Ti) **W5**

Group STAUFF	DIN	Dimensions (mm/m)					Order Codes (Standard Options)
		L1	L2	B	S	ØD	
3S	1	55	33	30	8	11	DPAL 3S W2
		2.16	1.30	1.18	.31	.43	
4S	2	70	45	30	8	11	DPAL 4S W2
		2.76	1.77	1.18	.31	.43	
5S	3	85	60	30	8	11	DPAL 5S W2
		3.35	2.36	1.18	.31	.43	
6S	4	115	90	45	10	14	DPAL 6S W2
		4.53	3.54	1.77	.39	.55	
7S	5	152	122	60	10	19	DPAL 7S W2
		5.98	4.80	2.36	.39	.75	
8S	6	206	168	80	15	22	DPAL 8S W1
		8.11	6.61	3.15	.59	.87	
9S	7	251	205	90	15	26	DPAL 9S W1
		9.88	8.07	3.54	.59	1.02	
10S	8	320	265	120	25	35	DPAL 10S W1
		12.60	10.43	4.72	.98	1.38	
11S	9	470	395	160	30	35	DPAL 11S W1
		18.50	15.55	6.30	1.18	1.38	
12S	10	630	534	180	30	35	DPAL 12S W1
		24.80	21.02	7.09	1.18	1.38	

Alternative materials and surface finishings are available upon request. Consult STAUFF for further information.

**Cover Plate for Double Clamps
Type DPAS**

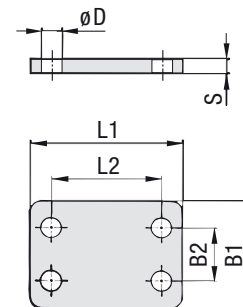
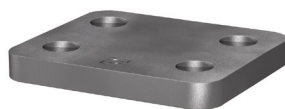

Order Codes

Cover Plate

***DPAS*3S*W2**

- * Cover Plate for Double Clamps **DPAS**
- * STAUFF Group **3S**
- * Material code
 - Carbon Steel, untreated **W1**
 - Carbon Steel, phosphated **W2**
 - Carbon Steel, zinc/nickel-plated **W3**
 - Stainless Steel V2A **W4**
 - 1.4301 / 1.4305 (AISI 304 / 303) **W4**
 - Stainless Steel V4A **W5**
 - 1.4401 / 1.4571 (AISI 316 / 316 Ti) **W5**

Group STAUFF	DIN	Dimensions (mm/m)					Order Codes (Standard Options)	
		L1	L2	B1	B2	S		ØD
3S	1	55	33	60	30,5	8	11	DPAS 3S W2
		2.16	1.30	2.36	1.20	.31	.43	
4S	2	70	45	60	30,5	8	11	DPAS 4S W2
		2.76	1.77	2.36	1.20	.31	.43	
5S	3	85	60	60	30,5	8	11	DPAS 5S W2
		3.35	2.36	2.36	1.20	.31	.43	
6S	4	115	90	90	46	10	14	DPAS 6S W2
		4.53	3.54	3.54	1.81	.39	.55	
7S	5	152	122	120	61	10	19	DPAS 7S W2
		5.98	4.80	4.72	2.40	.39	.75	
8S	6	206	168	160	81	15	22	DPAS 8S W1
		8.11	6.61	6.61	3.19	.59	.87	
9S	7	251	205	180	91	15	26	DPAS 9S W1
		9.88	8.07	7.09	3.58	.59	1.02	
10S	8	320	265	240	121	25	35	DPAS 10S W1
		12.60	10.43	9.45	4.78	.98	1.38	
11S	9	470	395	321	166	30	35	DPAS 11S W1
		18.50	15.55	12.64	6.54	1.18	1.38	
12S	10	630	534	361	186	30	35	DPAS 12S W1
		24.80	21.02	14.21	7.32	1.18	1.38	

Alternative materials and surface finishings are available upon request. Consult STAUFF for further information.

Hexagon Head Bolt Type AS

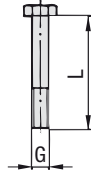
Hexagon Head Bolt AS

(according to DIN 931 / 933 or ANSI / ASME B18.2.1.)

Dimensions applicable only when used with Cover Plates DPAL or DPAS



Group STAUFF	DIN	Dimensions (mm/in) Thread G x L	Order Codes (Standard Options)
3S	1	M10 x 45	AS 3S M W1
		3/8-16 UNC x 1-3/4	AS 3S U W3*
4S	2	M10 x 60	AS 4S M W1
		3/8-16 UNC x 2-1/4	AS 4S U W3*
5S	3	M10 x 70	AS 5S M W1
		3/8-16 UNC x 2-3/4	AS 5S U W3*
6S	4	M12 x 100	AS 6S M W1
		7/16-14 UNC x 4	AS 6S U W3*
7S	5	M16 x 130	AS 7S M W1
		5/8-11 UNC x 5-1/4	AS 7S U W3*
8S	6	M20 x 190	AS 8S M W1
		3/4-10 UNC x 7-1/2	AS 8S U W1
9S	7	M24 x 220	AS 9S M W1
		7/8-9 UNC x 8-3/4	AS 9S U W1
10S	8	M30 x 300	AS 10S M W1
		1-1/8-7 UNC x 12	AS 10S U W1
11S	9	M30 x 450	AS 11S M W1
		1-1/4-7 UNC x 17-1/2	AS 11S U W1
12S	10	M30 x 560	AS 12S M W1
		1-1/4-7 UNC x 22	AS 12S U W1

Order Codes

Hexagon Head Bolt *AS*3S*M*W1

* Type of bolt	Hexagon Head Bolt (according to DIN 931 / 933 or ANSI / ASME B18.2.1.)	AS
* STAUFF Group		3S
* Thread code	Metric ISO thread	M
	Unified coarse (UNC) thread	U
* Material code	Carbon Steel, untreated	W1
	Carbon Steel, zinc/nickel-plated	W3
	Stainless Steel V2A	W4
	1.4301 / 1.4305 (AISI 304 / 303)	
	Stainless Steel V4A	W5
1.4401 / 1.4571 (AISI 316 / 316 Ti)		

* Standard finishing option for Heavy Series group sizes 3S to 7S in North America is W3 (Carbon Steel, zinc/nickel-plated).

All threaded parts are available with Metric ISO thread or unified coarse (UNC) thread according to dimension table. Alternative materials and surface finishings are available upon request. Consult STAUFF for further information.

Socket Cap Screw Type IS

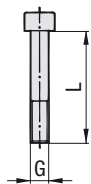
Socket Cap Screw IS

(according to ISO 4762 or ANSI / ASME B18.3)

Dimensions applicable only when used without Cover Plates



Group STAUFF	DIN	Dimensions (mm/in) Thread G x L	Order Codes (Standard Options)
3S	1	M10 x 30	IS 3S M W1
		3/8-16 UNC x 1-3/4	IS 3S U W3*
4S	2	M10 x 40	IS 4S M W1
		3/8-16 UNC x 2-1/4	IS 4S U W3*
5S	3	M10 x 50	IS 5S M W1
		3/8-16 UNC x 2-3/4	IS 5S U W3*
6S	4	M12 x 80	IS 6S M W1
		7/16-14 UNC x 4	IS 6S U W3*

Order Codes

Socket Cap Screw *IS*3S*M*W1

* Type of Bolt	Socket Cap Screw (according to ISO 4762 or ANSI / ASME B18.3)	IS
* STAUFF Group		3S
* Thread code	Metric ISO thread	M
	Unified coarse (UNC) thread	U
* Material code	Carbon Steel, untreated	W1
	Carbon Steel, zinc/nickel-plated	W3
	Stainless Steel V2A	W4
	1.4301 / 1.4305 (AISI 304 / 303)	
	Stainless Steel V4A	W5
1.4401 / 1.4571 (AISI 316 / 316 Ti)		

All threaded parts are available with Metric ISO thread or unified coarse (UNC) thread according to dimension table. Alternative materials and surface finishings are available upon request. Consult STAUFF for further information.

* Standard finishing option in North America is W3 (Carbon Steel, zinc/nickel-plated).

Safety Washer
Type SI (DIN 93)

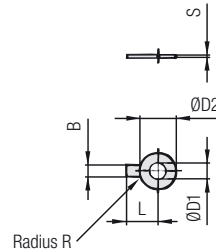

Safety Washer SI (according to DIN 93)

Order Codes

Safety Washer *SI*10,5*DIN 93*W3

- * Safety Washer **SI**
- * Exact inner diameter ØD1 (mm) **10,5**
- * Type of washer Safety washer with 1 tab (according to DIN 93) **DIN 93**
- * Material code Carbon Steel, zinc/nickel-plated **W3**

Group STAUFF	DIN	Dimensions (mm/m)						Order Codes (Standard Options)
		ØD1	B	ØD2	L	R	S	
3S	1	10,5	10	26	22	4	0,75	SI 10,5 DIN 93 W3
		.41	.39	1.02	.87	.16	.03	
4S	2	10,5	10	26	22	4	1	SI 10,5 DIN 93 W3
		.41	.39	1.02	.87	.16	.04	
5S	3	10,5	10	26	22	4	1	SI 10,5 DIN 93 W3
		.41	.39	1.02	.87	.16	.04	
6S	4	13	12	30	28	6	1	SI 13 DIN 93 W3
		.51	.47	1.18	1.10	.24	.04	
7S	5	17	15	36	32	6	1	SI 17 DIN 93 W3
		.67	.59	1.42	1.26	.24	.04	
8S	6	21	18	42	36	6	1	SI 21 DIN 93 W3
		.83	.71	1.65	1.42	.24	.04	
9S	7	25	20	50	42	6	1	SI 25 DIN 93 W3
		.98	.79	1.97	1.65	.24	.04	
10S	8	31	26	63	52	10	1,6	SI 31 DIN 93 W3
		1.22	1.02	2.48	2.05	.39	.06	
11S	9	31	26	63	52	10	1,6	SI 31 DIN 93 W3
		1.22	1.02	2.48	2.05	.39	.06	
12S	10	31	26	63	52	10	1,6	SI 31 DIN 93 W3
		1.22	1.02	2.48	2.05	.39	.06	

Safety Washers, type SI are used as locking devices to prevent Hexagon Head Bolts, type AS from loosening. Alternative materials and surface finishings are available upon request. Consult STAUFF for further information.

Safety Washer
Type SI (DIN 463)

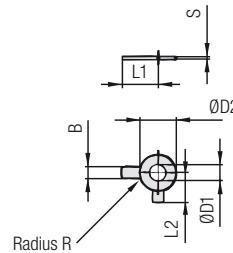

Safety Washer SI (according to DIN 463)

Order Codes

Safety Washer *SI*10,5*DIN 463*W3

- * Safety Washer **SI**
- * Exact inner diameter ØD1 (mm) **10,5**
- * Type of washer Safety washer with 2 tabs (according to DIN 463) **DIN 463**
- * Material code Carbon Steel, zinc/nickel-plated **W3**

Group STAUFF	DIN	Dimensions (mm/m)							Order Codes (Standard Options)
		ØD1	B	ØD2	L1	L2	R	S	
3S	1	10,5	10	21	22	13	4	0,75	SI 10,5 DIN 463 W3
		.41	.39	.83	.87	.51	.16	.03	
4S	2	10,5	10	21	22	13	4	1	SI 10,5 DIN 463 W3
		.41	.39	.83	.87	.51	.16	.04	
5S	3	10,5	10	21	22	13	4	1	SI 10,5 DIN 463 W3
		.41	.39	.83	.87	.51	.16	.04	
6S	4	13	12	24	28	15	6	1	SI 13 DIN 463 W3
		.51	.47	.94	1.10	.59	.24	.04	
7S	5	17	15	30	32	18	6	1	SI 17 DIN 463 W3
		.67	.59	1.18	1.26	.71	.24	.04	
8S	6	21	18	37	36	21	6	1	SI 21 DIN 463 W3
		.83	.71	1.46	1.42	.83	.24	.04	
9S	7	25	20	44	42	25	6	1	SI 25 DIN 463 W3
		.98	.79	1.73	1.65	.98	.24	.04	
10S	8	31	26	56	52	32	10	1,6	SI 31 DIN 463 W3
		1.22	1.02	2.20	2.05	1.26	.39	.06	
11S	9	31	26	56	52	32	10	1,6	SI 31 DIN 463 W3
		1.22	1.02	2.20	2.05	1.26	.39	.06	
12S	10	31	26	56	52	32	10	1,6	SI 31 DIN 463 W3
		1.22	1.02	2.20	2.05	1.26	.39	.06	

Safety Washers, type SI are used as locking devices to prevent Hexagon Head Bolts, type AS from loosening. Alternative materials and surface finishings are available upon request. Consult STAUFF for further information.

Safety Locking Plate (for Use with Stacking Bolt AF) Type SIP

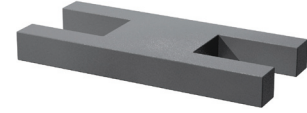
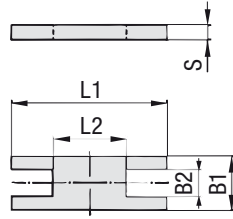

Group STAUFF	DIN	Dimensions (mm/in)					Order Codes (Standard Options)
		L1	L2	B1	B2	S	
3S	1	57	13	30	15,2	8	SIP 3S W2
		2.24	.51	1.18	.60	.31	
4S	2	70	26	30	15,2	8	SIP 4S W2
		2.76	1.02	1.18	.60	.31	
5S	3	85	40	30	15,2	8	SIP 5S W2
		3.35	1.57	1.18	.60	.31	
6S	4	116	68	45	17,2	10	SIP 6S W2
		4.57	2.68	1.77	.68	.39	
7S	5	153	96	60	22	10	SIP 7S W2
		6.02	3.78	2.36	.87	.39	
8S	6	206	130	80	28	15	SIP 8S W1
		8.11	5.12	3.15	1.10	.59	
9S	7	251	166	90	31	15	SIP 9S W1
		9.88	6.54	3.54	1.22	.59	
10S	8	317	205	120	49	25	SIP 10 S W1
		12.48	8.07	4.72	1.93	.98	

Order Codes

Safety Locking Plate

***SIP*3S*W2**

* Safety Locking Plate		SIP
* STAUFF Group		3S
* Material code	Carbon Steel, untreated	W1
	Carbon Steel, phosphated	W2
	Carbon Steel, zinc/nickel-plated	W3
	Stainless Steel V2A	W4
	1.4301 / 1.4305 (AISI 304 / 303)	W4
	Stainless Steel V4A	W5
	1.4401 / 1.4571 (AISI 316 / 316 Ti)	W5

Alternative materials and surface finishings are available upon request. Consult STAUFF for further information.

Stacking Bolt (for Use with Safety Locking Plate SIP) Type AF

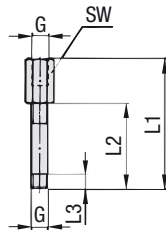

Group STAUFF	DIN	Dimensions (mm/in)					Order Codes (Standard Options)
		L1	L2	L3 min.	Hex	Thread G	
3S	1	49	25	15	15	M10	AF 3S M W2
		1.93	.98	.59	.59	3/8-16 UNC	AF 3S U W3*
4S	2	65	40	15	15	M10	AF 4S M W2
		2.56	1.57	.59	.59	3/8-16 UNC	AF 4S U W3*
5S	3	77	51	15	15	M10	AF 5S M W2
		3.03	2.01	.59	.59	3/8-16 UNC	AF 5S U W3*
6S	4	110	82	18	17	M12	AF 6S M W2
		4.33	3.23	.71	.67	7/16-14 UNC	AF 6S U W3*
7S	5	144	110	24	21	M16	AF 7S M W2
		5.67	4.33	.94	.83	5/8-11 UNC	AF 7S U W3*
8S	6	200	150	30	27	M20	AF 8S M W2
		7.87	5.91	1.18	1.06	3/4-10 UNC	AF 8S U W1*
9S	7	240	180	50	30	M24	AF 9S M W2
		9.45	7.09	1.97	1.18	7/8-9 UNC	AF 9S U W1*
10S	8	331	256	62	46	M30	AF 10S M W2
		13.03	10.08	2.44	1.81	1-1/8-7 UNC	AF 10S U W1*

Order Codes

Stacking Bolt

***AF*3S*M*W2**

* Stacking Bolt		AF
* STAUFF Group		3S
* Thread code	Metric ISO thread	M
	Unified coarse (UNC) thread	U
* Material code	Carbon Steel, untreated	W1
	Carbon Steel, phosphated	W2
	Carbon Steel, zinc/nickel-plated	W3
	Stainless Steel V2A	W4
	1.4301 / 1.4305 (AISI 304 / 303)	W4
	Stainless Steel V4A	W5
	1.4401 / 1.4571 (AISI 316 / 316 Ti)	W5

All threaded parts are available with Metric ISO thread or unified coarse (UNC) thread according to dimension table. Alternative materials and surface finishings are available upon request. Consult STAUFF for further information.

* Standard finishing option for Heavy Series group sizes 3S to 7S in North America is W3 (Carbon Steel, zinc/nickel-plated). Standard finishing option for Heavy Series group sizes 8S to 10S in North America is W1 (Carbon Steel, untreated).

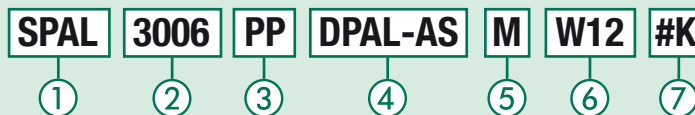

① Type of Installation

Please select the type of installation (e.g. Weld Plates, Rail Nuts, etc.) and add the corresponding Code to position ① of the order code for your clamp assembly.

Without Installation Equipment
Code: **none**

Installation on Weld Plate

Weld Plate for Single Clamps
Code: **SPAL**

Weld Plate for Double Clamps
Code: **SPAS**

Elongated Weld Plate for Single Clamps
Code: **SPAL/DUEB**

Elongated Weld Plate for Double Clamps
Code: **SPAS/DUEB**

Installation on Mounting / Channel Rail

Mounting Rail Nut
Code: **GMV** (for STAUFF Group 3S to 6S only)

Channel Rail Adaptor
Code: **CRA** (for STAUFF Group 3S to 6S only)

② Group Size & Diameter

Please select the required group size and diameter and add the corresponding Code to position ② of the order code for your clamp assembly.

Group STAUFF (DIN)	Outside Diameter P / T / H (mm)	Availability of Clamp Body Materials & Designs Profiled			Code
		Design	Type H	Type RI	
3S (1)	6	●	●	○	3006
	6,4	●	●	○	3006,4
	8	●	●	○	3008
	9,5	●	●	○	3009,5
	10	●	●	○	3010
	12	●	●	○	3012
	12,7	●	●	○	3012,7
	13,5	●	●	○	3013,5
	14	●	●	○	3014
	15	●	●	○	3015
	16	●	●	○	3016
	17,2	●	●	○	3017,2
	18	●	●	○	3018
20	●	○	○	3020	

② Group Size & Diameter
CONTINUATION

Group STAUFF (DIN)	Outside Diameter P / T / H (mm)	Availability of Clamp Body Materials & Designs Profiled			Code
		Design	Type H	Type RI	
4S (2)	6	○	○	●	4006
	8	○	○	●	4008
	10	○	○	●	4010
	12	○	○	●	4012
	12,7	○	○	●	4012,7
	14	○	○	●	4014
	15	○	●	●	4015
	16	○	○	●	4016
	17,2	○	○	●	4017,2
	18	○	○	●	4018
	19	●	●	●	4019
	19,8	○	●	○	4019,8
	20	●	●	○	4020
	21,3	●	●	○	4021,3
	22	●	●	○	4022
	22,1	○	●	○	4022,1
	25	●	●	○	4025
	25,1	○	●	○	4025,1
	25,4	●	●	○	4025,4
26,9	●	●	○	4026,9	
28	○	●	○	4028	
29,2	○	●	○	4029,2	
30	●	●	○	4030	
5S (3)	20	○	○	●	5020
	21,3	○	○	●	5021,3
	22	○	○	●	5022
	25	○	○	●	5025
	26,9	○	○	●	5026,9
	28	○	○	●	5028
	30	●	●	○	5030
	32	●	●	○	5032
	33,7	●	●	○	5033,7
	35	●	●	○	5035
	38	●	●	○	5038
	40	●	●	○	5040
	41,3	●	●	○	5041,3
42	●	●	○	5042	
6S (4)	32	○	○	●	6032
	33,7	○	○	●	6033,7
	35	○	○	●	6035
	37,8	○	●	○	6037,8
	38	●	●	○	6038
	38,7	○	○	●	6038,7
	40	○	○	●	6040
	42	●	●	●	6042
	44,5	●	●	○	6044,5
	45,5	○	○	●	6045,5
	48	○	○	●	6048
	48,3	●	●	○	6048,3
	48,4	○	●	○	6048,4
	50,8	●	●	○	6050,8
	51	○	○	●	6051
	53,4	○	○	●	6053,4
	54	●	○	○	6054
54,4	○	●	○	6054,4	

② Group Size & Diameter
CONTINUATION

Group STAUFF (DIN)	Outside Diameter P / T / H (mm)	Availability of Clamp Body Materials & Designs Profiled			Code	
		Design	Type H	Type RI		
6S (4)	55	●	●	○	6055	
	56,4	○	○	●	6056,4	
	57	●	●	○	6057	
	57,2	●	●	○	6057,2	
	60,3	●	●	○	6060,3	
	63,5	●	●	○	6063,5	
	65	●	●	○	6065	
	70	●	●	○	6070	
	7S (5)	55	○	○	●	7055
		57	○	○	●	7057
60		○	○	●	7060	
60,3		●	○	○	7060,3	
63,5		○	○	●	7063,5	
65		●	○	●	7065	
70		●	○	●	7070	
72		○	○	●	7072	
73		●	○	○	7073	
75		●	○	○	7075	
76		○	○	●	7076	
76,1		●	○	○	7076,1	
80		●	○	○	7080	
82,5	●	○	○	7082,5		
88,9	●	○	○	7088,9		
8S (6)	80	○	○	●	8080	
	88,9	●	○	●	8088,9	
	100	●	○	○	8100	
	102	●	○	●	8102	
	108	●	○	○	8108	
	114	●	○	○	8114	
	127	●	○	○	8127	
	133	●	○	○	8133	
	9S (7)	114	○	○	●	9114
		127	●	○	○	9127
133		●	○	●	9133	
140		●	○	●	9140	
152		●	○	○	9152	
159		●	○	○	9159	
165		●	○	○	9165	
168	●	○	○	9168		
10S (8)	150	○	○	●	10150	
	165	○	○	●	10165	
	168	●	○	●	10168	
	172	○	○	●	10172	
	177,8	●	○	○	10177,8	
	193,7	●	○	○	10193,7	
	203	●	○	○	10203	
216	●	○	○	10216		
219	●	○	○	10219		
11S (9)	219	●	○	○	11219	
	273	●	○	○	11273	
12S (10)	324	●	○	○	11324	
	356	●	○	○	12356	
406	●	○	○	12406		

● Standard Option

Additional outside diameters are available upon request. Please consult STAUFF for further information.

Please see pages A38 and A39 with detailed order examples for some of the most popular Heavy Series clamp assemblies.

③ Clamp Body Design & Material

Please select the design and material of your clamp body and add the corresponding **Code** to position ③ of the order code for your clamp assembly.

Please check the availability of the selected clamp body design and material according to the matrix table in ②.

Profiled Design



Polypropylene
Code: **PP**



Polyamide
Code: **PA**



Thermoplastic Elastomer (87 Shore-A)
Code: **SA** (for STAUFF Group 3S to 6S only)



Aluminium
Code: **AL**

Type H (Smooth)



Polypropylene
Code: **PPH** (for STAUFF Group 3S to 6S only)



Polyamide
Code: **PAH** (for STAUFF Group 3S to 6S only)



Thermoplastic Elastomer (87 Shore-A)
Code: **SAH** (for STAUFF Group 3S to 6S only)

Type RI (with Rubber Insert)



Polypropylene
Code: **PPR** (for STAUFF Group 4S to 10S only)



Polyamide
Code: **PAR** (for STAUFF Group 4S to 10S only)

See page A86 for material properties and technical information.

Please consult STAUFF for further details on fire-proof and corrosion preventing clamp body materials, tested and approved according to several international fire-protection standards.

④ Mounting & Fitting Combination

Please select the mounting and fitting combination (e.g. bolts, screws, cover plates, etc.) and add the corresponding **Code** to position ④ of the order code for your clamp assembly.

Installation with Cover Plate and Bolts

Cover Plate for Single Clamps DPAL with Hexagon Head Bolts AS
Code: **DPAL-AS**

Cover Plate for Double Clamps DPAS with Hexagon Head Bolts AS
Code: **DPAS-AS**

Cover Plate for Single Clamps DPAL with Socket Cap Screws IS*
Code: **DPAL-IS** (for STAUFF Group 3S to 6S only)

Installation with Locking Plate and Bolts

Safety Locking Plate SIP with Stacking Bolts AF
Code: **SIP-AF**

Installation with Bolts only

Socket Cap Screws IS
Code: **IS**

* Special lengths of Socket Cap Screws IS required. For exact lengths, please see details of Hexagon Head Bolt, type AS (for use with Cover Plates DPAL or DPAS) on page A33.

⑤ Thread Type

Please select the required thread type and add the corresponding **Code** to position ⑤ of the order code for your clamp assembly.

Metric ISO thread
Code: **M**

Unified coarse (UNC) thread
Code: **U**

All threaded parts are available with Metric ISO thread or unified coarse (UNC) thread according to dimension table.

⑥ Material & Surface Finishing

Please select the required material & surface finishing of the metal parts and add the corresponding **Code** to position ⑥ of the order code for your clamp assembly.

Metal parts made of Carbon Steel, untreated **W1**

Metal parts made of Carbon Steel, phosphated **W2**

Metal parts made of Carbon Steel, zinc/nickel-plated **W3**

Metal parts made of Stainless Steel V2A 1.4301 / 1.4305 (AISI 304 / 303) **W4**

Metal parts made of Stainless Steel V4A 1.4401 / 1.4571 (AISI 316 / 316 Ti) **W5**

Weld Plate made of Carbon Steel, phosphated; Other metal parts made of Carbon Steel, zinc/nickel-plated **W10**

Weld Plate and Cover Plate made of Carbon Steel, phosphated; Bolts made of Carbon Steel, untreated **W12**

Mounting Rail Nuts made of Carbon Steel, zinc/nickel-plated; Cover Plate made of Carbon Steel, phosphated; Bolts made of Carbon Steel, untreated **W13**

Weld Plate / Cover Plate made of Carbon Steel, phosphated; Bolts made of Carbon Steel, zinc/nickel-plated **W15**

Mounting Rail Nuts made of Carbon Steel, zinc/nickel-plated; Cover Plate made of Carbon Steel, phosphated; Bolts made of Carbon Steel, zinc/nickel-plated **W16**

Safety Locking Plate made of Carbon Steel, phosphated; Bolts made of Carbon Steel, zinc/nickel-plated **W17**

Safety Locking Plate made of Carbon Steel, untreated; Bolts made of Carbon Steel, phosphated **W18**

Cover Plate made of Carbon Steel, phosphated; Bolts made of Carbon Steel, untreated **W19**

Individual combinations of alternative materials and surface finishings are available upon request. Consult STAUFF for further information.

⑦ Assembling & Kitting

If required, please select an additional assembling and kitting option and add the corresponding **Code** to the last position of the order code for your clamp assembly.

Components supplied separately
Code: **none** (standard option)

Components assembled
Code: **#A** (special option)

Components packed in kits
Code: **#K** (special option)

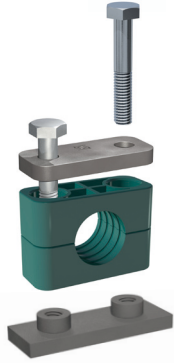

- 2x **Hexagon Head Bolt**
Surface: W1
Thread: Metric
- 1x **Cover Plate for Single Clamps**
Surface: W2
- 1x **Clamp Body** (two halves)
STAUFF Group 3S (DIN 1)
O.D. 6 mm / .24 in
Material: Polypropylene
Profiled inside surface with tension clearance
- 1x **Weld Plate for Single Clamps**
Surface: W2
Thread: Metric

Order Code

SPAL 3006 PP DPAL-AS M W12

W12 (STAUFF Group 3S to 7S) and W1 (STAUFF Group 8S to 12S) are the standard options for this type of installation.



- 4x **Hexagon Head Bolt**
Surface: W1
Thread: Metric
- 1x **Cover Plate for Double Clamps**
Surface: W2
- 2x **Clamp Body** (four halves)
STAUFF Group 3S (DIN 1)
O.D. 6 mm / .24 in
Material: Polypropylene
Profiled inside surface with tension clearance
- 1x **Weld Plate for Double Clamps**
Surface: W2
Thread: Metric

Order Code

SPAS 3006 PP DPAS-AS M W12

W12 (STAUFF Group 3S to 7S) and W1 (STAUFF Group 8S to 12S) are the standard options for this type of installation.



- 2x **Hexagon Head Bolt**
Surface: W1
Thread: Metric
- 1x **Cover Plate for Single Clamps**
Surface: W2
- 1x **Clamp Body** (two halves)
STAUFF Group 3S (DIN 1)
O.D. 6 mm / .24 in
Material: Polypropylene
Profiled inside surface with tension clearance
- 1x **Elongated Weld Plate for Single Clamps**
Surface: W2
Thread: Metric

Order Code

SPAL/DUEB 3006 PP DPAL-AS M W12

W12 (STAUFF Group 3S to 7S) and W1 (STAUFF Group 8S to 12S) are the standard options for this type of installation.

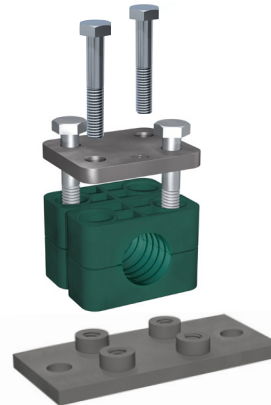

- 4x **Hexagon Head Bolt**
Surface: W1
Thread: Metric
- 1x **Cover Plate for Double Clamps**
Surface: W2
- 2x **Clamp Body** (four halves)
STAUFF Group 3S (DIN 1)
O.D. 6 mm / .24 in
Material: Polypropylene
Profiled inside surface with tension clearance
- 1x **Elongated Weld Plate for Double Clamps**
Surface: W2
Thread: Metric

Order Code

SPAS/DUEB 3006 PP DPAS-AS M W12

W12 (STAUFF Group 3S to 7S) and W1 (STAUFF Group 8S to 12S) are the standard options for this type of installation.

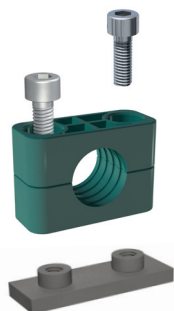

- 2x **Socket Cap Screw**
Surface: W1
Thread: Metric
- 1x **Clamp Body** (two halves)
STAUFF Group 3S (DIN 1)
O.D. 6 mm / .24 in
Material: Polypropylene
Profiled inside surface with tension clearance
- 1x **Weld Plate for Single Clamps**
Surface: W2
Thread: Metric

Order Code

SPAL 3006 PP IS M W12

W12 is the standard option for this type of installation. Available up to STAUFF Group 6S (DIN Group 4) only.

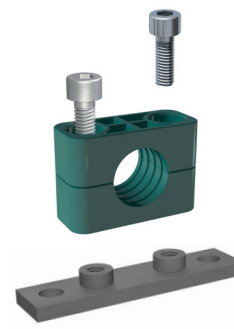

- 2x **Socket Cap Screw**
Surface: W1
Thread: Metric
- 1x **Clamp Body** (two halves)
STAUFF Group 3S (DIN 1)
O.D. 6 mm / .24 in
Material: Polypropylene
Profiled inside surface with tension clearance
- 1x **Elongated Weld Plate for Single Clamps**
Surface: W2
Thread: Metric

Order Code

SPAL/DUEB 3006 PP IS M W12

W12 is the standard option for this type of installation. Available up to STAUFF Group 6S (DIN Group 4) only.



- 2x **Hexagon Head Bolt**
Surface: W1
Thread: Metric
- 1x **Cover Plate for Single Clamps**
Surface: W2
- 1x **Clamp Body** (two halves)
STAUFF Group 3S (DIN 1)
O.D. 6 mm / .24 in
Material: Polypropylene
Profiled inside surface with tension clearance
- 2x **Mounting Rail Nut**
Surface: W3
Thread: Metric

Order Code (Mounting Rail STSV not included.)

GMV 3006 PP DPAL-AS M W13

W13 is the standard option for this type of installation. Available up to STAUFF Group 6S (DIN Group 4) only.



- 2x **Socket Cap Screw**
Surface: W1
Thread: Metric
- 1x **Clamp Body** (two halves)
STAUFF Group 3S (DIN 1)
O.D. 6 mm / .24 in
Material: Polypropylene
Profiled inside surface with tension clearance
- 2x **Mounting Rail Nut**
Surface: W3
Thread: Metric

Order Code (Mounting Rail STSV not included.)

GMV 3006 PP IS M W13

W13 is the standard option for this type of installation. Available up to STAUFF Group 6S (DIN Group 4) only.



- 2x **Hexagon Head Bolt**
Surface: W1
Thread: Metric
- 1x **Cover Plate for Single Clamps**
Surface: W2
- 1x **Clamp Body** (two halves)
STAUFF Group 3S (DIN 1)
O.D. 6 mm / .24 in
Material: Polypropylene
Profiled inside surface with tension clearance

Order Code

3006 PP DPAL-AS M W19

W19 (STAUFF Group 3S to 7S) and **W1** (STAUFF Group 8S to 12S) are the standard options for this type of installation.

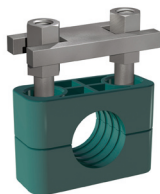

- 2x **Stacking Bolt**
Surface: W2
Thread: Metric
- 1x **Safety Locking Plate**
Surface: W2
- 1x **Clamp Body** (two halves)
STAUFF Group 3S (DIN 1)
O.D. 6 mm / .24 in
Material: Polypropylene
Profiled inside surface with tension clearance

Order Code

3006 PP SIP-AF M W2

W2 (STAUFF Group 3S to 7S) and **W18** (STAUFF Group 8S to 10S) are the standard options for this type of installation. Available up to STAUFF Group 10S (DIN Group 8) only.

Thread codes

All threaded parts are available with Metric ISO thread or unified coarse (UNC) thread according to dimension table.

Metric ISO thread	M
Unified coarse (UNC) thread	U

Material codes

The below listed material codes describe the materials and surface finishings of metal parts that are most relevant for Heavy Series clamp assemblies. Individual combinations of alternative materials and surface finishings are available upon request. Consult STAUFF for further information.

Metal parts made of Carbon Steel, untreated	W1
Metal parts made of Carbon Steel, phosphated	W2
Metal parts made of Carbon Steel, zinc/nickel-plated	W3
Metal parts made of Stainless Steel V2A: 1.4301 / 1.4305 (AISI 304 / 303)	W4
Metal parts made of Stainless Steel V4A: 1.4401 / 1.4571 (AISI 316 / 316 Ti)	W5
Weld Plate made of Carbon Steel, phosphated; Other metal parts made of Carbon Steel, zinc/nickel-plated	W10
Weld Plate and Cover Plate made of Carbon Steel, phosphated; Bolts made of Carbon Steel, untreated	W12
Mounting Rails Nut made of Carbon Steel, zinc/nickel-plated; Cover Plate made of Carbon Steel, phosphated; Bolts made of Carbon Steel, untreated	W13
Weld Plate and Cover Plate made of Carbon Steel, phosphated; Bolts made of Carbon Steel, zinc/nickel-plated	W15
Mounting Rail Nuts made of Carbon Steel, zinc/nickel-plated; Cover Plate made of Carbon Steel, phosphated; Bolts made of Carbon Steel, zinc/nickel-plated	W16
Safety Locking Plate made of Carbon Steel, phosphated; Bolts made of Carbon Steel, zinc/nickel-plated	W17
Safety Locking Plate made of Carbon Steel, untreated; Bolts made of Carbon Steel, phosphated	W18
Cover Plate made of Carbon Steel, phosphated; Bolts made of Carbon Steel, untreated	W19

Clamp Body ▀ Profiled Design

Profiled Inside Surface with Tension Clearance

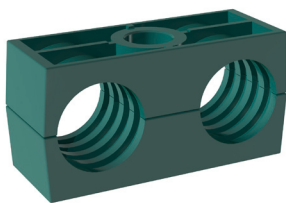

Clamp Body ▀ Type H

Smooth Inside Surface w/o Tension Clearance

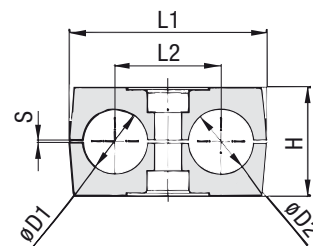
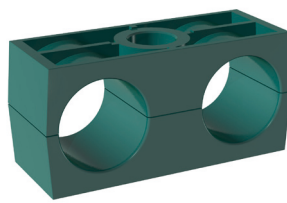

Order Codes

Clamp Body

***1*06/06*PP**

One clamp body is consisting of two clamp halves.

- * 1st Part of STAUFF Group **1**
- * Exact outside diameters Ø D1 / Ø D2 (mm) **06/06**
- * Material code (see below) **PP**

Designs & Standard Materials



Polypropylene ▀ Profiled Design

Profiled inside surface with tension clearance

Colour: Green

Material code: **PP**



Polypropylene ▀ Type H

Smooth inside surface without tension clearance

Colour: Green

Material code: **PPH**



Polyamide ▀ Profiled Design

Profiled inside surface with tension clearance

Colour: Black

Material code: **PA**



Polyamide ▀ Type H

Smooth inside surface without tension clearance

Colour: Black

Material code: **PAH**

See page A86 for properties and technical information.

Special Materials

Please consult STAUFF for further details on fire-proof and corrosion preventing clamp body materials, tested and approved according to several international fire-protection standards.

See page A87 for properties and technical information.

Product Features

- “ Proven, tested and trusted product in various markets
- “ Profiled design recommended for the safe installation of rigid pipes and tubes; type H recommended for the safe installation of hoses and cables
- “ Available for all commonly used pipe and tube outside diameters
- “ Environmental protection due to vibration/noise reducing design
- “ Excellent weathering resistance, even under extreme conditions

Group	STAUFF	DIN	Outside Diameter		Nominal Bore		Order Codes (2 Clamp Halves) (*** = Material)	Dimensions (mm/in)									
			Pipe / Tube / Hose Ø D1 / Ø D2 (mm) (in)		Pipe (in)	Copper Tube (in)		L1	L2	H	S min.	Type H H	Width				
1D	1	6					106/06 ***										
		6,4	1/4				106,4/06,4 ***										
		8	5/16				108/08 ***	36	20	27	0,6	26,5	30				
		9,5	3/8		1/4		109,5/09,5 ***	1.42	.79	1.06	.02	1.04	1.18				
		10			1/8		110/10 ***										
		12					112/12 ***										
2D	2	12,7	1/2		3/8		212,7/12,7 ***										
		13,5			1/4		213,5/13,5 ***										
		14					214/14 ***										
		15					215/15 ***	53	29	27	0,7	26,5	30				
		16	5/8		1/2		216/16 ***	2.09	1.14	1.06	.03	1.04	1.18				
		17,2			3/8		217,2/17,2 ***										
3D	3	18					218/18 ***										
		19	3/4				319/19 ***										
		20					320/20 ***										
		21,3			1/2		321,3/21,3 ***	67	36	37	0,7	36,5	30				
		22			3/4		322/22 ***	2.64	1.42	1.46	.03	1.44	1.18				
		25					325/25 ***										
4D	4	25,4	1				325,4/25,4 ***										
		26,9			3/4		426,9/26,9 ***	80	45	40	0,7	38	30				
		28					428/28 ***	3.15	1.77	1.57	.03	1.46	1.18				
5D	5	30					430/30 ***										
		32	1-1/4				532/32 ***										
		33,7			1		533,7/33,7 ***										
		35			1-1/4		535/35 ***	106	56	53	0,7	52	30				
		38	1-1/2				538/38 ***	4.17	2.20	2.09	.03	2.04	1.18				
		40					540/40 ***										
42			1-1/4		542/42 ***												

Additional outside diameters and combinations of different outside diameters are available upon request. Please consult STAUFF for further information.

Single Weld Plate Type SP

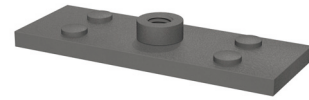
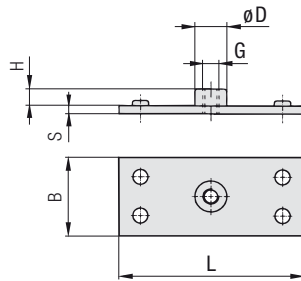

Group STAUFF	DIN	Dimensions (mm/in)						Order Codes (Standard Options)	
		L	B	S	H	ØD	Thread G		
1D	1	37	30	3	6,5	12	M6	SP 1D M W2	
		1.46	1.18	.12	.26	.47	1/4-20 UNC	SP 1D U W2	
2D	2	55	30	5	6	14	M8	SP 2D M W2	
		2.17	1.18	.20	.24	.55	5/16-18 UNC	SP 2D U W2	
3D	3	70	30	5	6	14	M8	SP 3D M W2	
		2.76	1.18	.20	.24	.55	5/16-18 UNC	SP 3D U W2	
4D	4	85	30	5	6	14	M8	SP 4D M W2	
		3.35	1.18	.20	.24	.55	5/16-18 UNC	SP 4D U W2	
5D	5	110	30	5	6	14	M8	SP 5D M W2	
		4.33	1.18	.20	.24	.55	5/16-18 UNC	SP 5D U W2	

All threaded parts are available with Metric ISO thread or unified coarse (UNC) thread according to dimension table. Alternative materials and surface finishings are available upon request. Consult STAUFF for further information.

Order Codes

Weld Plate

***SP*1D*M*W2**

* Single Weld Plate		SP
* STAUFF Group		1D
* Thread code	Metric ISO thread	M
	Unified coarse (UNC) thread	U
* Material code	Carbon Steel, untreated	W1
	Carbon Steel, phosphated	W2
	Carbon Steel, zinc/nickel-plated	W3
	Stainless Steel V2A	W4
	1.4301 / 1.4305 (AISI 304 / 303)	W4
	Stainless Steel V4A	W5
	1.4401 / 1.4571 (AISI 316 / 316 Ti)	W5

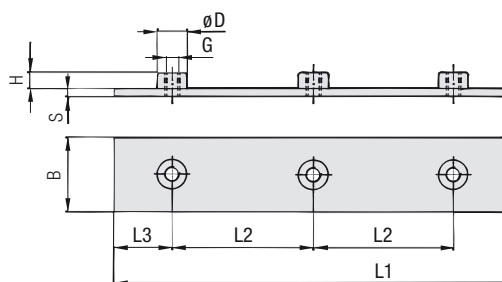

Group Weld Plate Type RAP

Group STAUFF	DIN	Dimensions (mm/in)							Order Codes (Standard Options)		
		L1	L2	L3	B	S	H	ØD	Thread G		
1D	1	196	40	18	30	3	6,5	12	M6	RAP 1D/40/5 M W1	
		7.72	1.57	.71	1.18	.12	.26	.47	1/4-20 UNC	RAP 1D/40/5 U W1	
2D	2	288	58	28	30	5	6	14	M8	RAP 2D/58/5 M W1	
		11.34	2.28	1.10	1.18	.20	.24	.55	5/16-18 UNC	RAP 2D/58/5 U W1	
3D	3	358	72	35	30	5	6	14	M8	RAP 3D/72/5 M W1	
		14.09	2.83	1.37	1.18	.20	.24	.55	5/16-18 UNC	RAP 3D/72/5 U W1	
4D	4	445	90	42	30	5	6	14	M8	RAP 4D/90/5 M W1	
		17.52	3.54	1.65	1.18	.20	.24	.55	5/16-18 UNC	RAP 4D/90/5 U W1	
5D	5	558	112	55	30	5	6	14	M8	RAP 5D/112/5 M W1	
		21.97	4.41	2.16	1.18	.20	.24	.55	5/16-18 UNC	RAP 5D/112/5 U W1	

All threaded parts are available with Metric ISO thread or unified coarse (UNC) thread according to dimension table. Alternative materials and surface finishings are available upon request. Consult STAUFF for further information.

Order Codes

Weld Plate

***RAP*1D/40/5*M*W1**

* Group Weld Plate		RAP
* STAUFF Group		1D
* Pipe Center Spacing L2 (mm)		40
* Number of Clamps		5
* Thread code	Metric ISO thread	M
	Unified coarse (UNC) thread	U
* Material code	Carbon Steel, untreated	W1
	Carbon Steel, phosphated	W2
	Carbon Steel, zinc/nickel-plated	W3
	Stainless Steel V2A	W4
	1.4301 / 1.4305 (AISI 304 / 303)	W4
	Stainless Steel V4A	W5
	1.4401 / 1.4571 (AISI 316 / 316 Ti)	W5

Hexagon Rail Nut

Type SM (for Use with Mounting Rail TS)

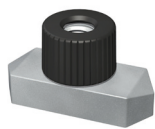

STAUFF Group 1D

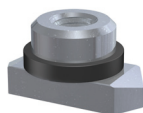

STAUFF Group 2D to 5D

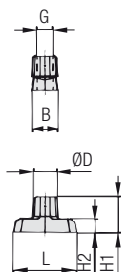

STAUFF Group 1D

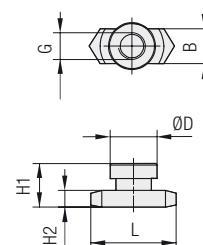

STAUFF Group 2D to 5D

Order Codes

Hexagon Rail Nut ***SM*1-8/1D*M*W1**

* Hexagon Rail Nut		SM
* STAUFF Group	1D (DIN Group 1) 2D to 5D (DIN Group 2 to 5)	1-8/1D 2-5D
* Thread code	Metric ISO thread Unified coarse (UNC) thread	M U
* Material code	Carbon Steel, untreated Carbon Steel, zinc/nickel-plated Stainless Steel V2A 1.4301 / 1.4305 (AISI 304 / 303) Stainless Steel V4A 1.4401 / 1.4571 (AISI 316 / 316 Ti)	W1 W3 W4 W5

Group STAUFF	DIN	Dimensions (mm/m)						Order Codes (Standard Options)
		Thread G	L	B	H1	H2	ØD	
1D	1	M6	25,5	10,2	13,5	5,5	12	SM 1-8/1D M W1
		1/4-20 UNC	1.00	.40	.53	.22	.47	SM 1-8/1D U W3*
2D	2							
3D	3							
4D	4	M8	25,5	10,4	13	5	14	SM 2-5D M W3
		5/16-18 UNC	1.00	.41	.51	.20	.55	SM 2-5D U W3
5D	5							

The Hexagon Rail Nut, type SM 1-8/1D is also suitable for Standard Series, STAUFF Group 1 to 8.

All threaded parts are available with Metric ISO thread or unified coarse (UNC) thread according to dimension table. Alternative materials and surface finishings are available upon request. Consult STAUFF for further information.

* Standard finishing option for Twin Series group size 1D in North America is W3 (Carbon Steel, zinc/nickel-plated).

Mounting Rail

Type TS (for Use with Hexagon Rail Nut SM)

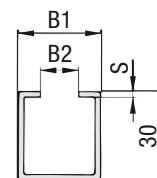
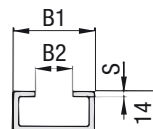
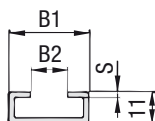
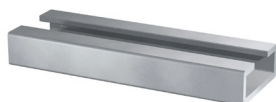

Mounting Rail TS 11

Mounting Rail TS 14

Mounting Rail TS 30

Order Codes

Mounting Rail ***TS*11*-1*W1**

* Mounting Rail		TS
* Height of rail	11 mm / .43 in 14 mm / .55 in 30 mm / 1.18 in	11 14 30
* Length of rail	1 m / 3.28 ft 2 m / 6.56 ft	-1 -2
	Alternative lengths available upon request. Consult STAUFF for further information.	
* Material code	Carbon Steel, untreated Carbon Steel, zinc/nickel-plated Stainless Steel V2A 1.4301 / 1.4305 (AISI 304 / 303) Stainless Steel V4A 1.4401 / 1.4571 (AISI 316 / 316 Ti)	W1 W3 W4 W5

Group STAUFF	DIN	Dimensions (mm/m)			Order Codes (Standard Options)	
		L	B	H1	Length of Rail: 1 m / 3.28ft	Length of Rail: 2 m / 6.56ft
1D	1				Height 11 mm / .43 in TS 11-1 W1	Height 11 mm / .43 in TS 11-2 W1
2D	2					
3D	3	28 1.10	11 .43	2 .08	Height 14 mm / .55 in TS 14-1 W1	Height 14 mm / .55 in TS 14-2 W1
4D	4					
5D	5				Height 30 mm / 1.18 in TS 30-1 W1	Height 30 mm / 1.18 in TS 30-2 W1

Mounting Rails, type TS 11/14/30 are suitable for all Twin Series and Standard Series group sizes.

Alternative materials and surface finishings are available upon request. Consult STAUFF for further information.

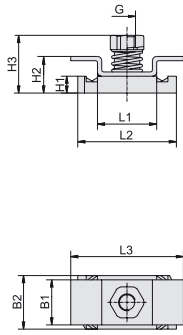
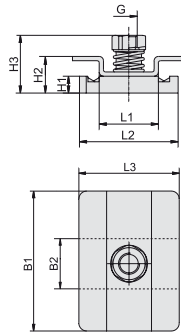
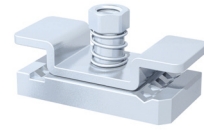
STAUFF Group 1D

STAUFF Group 2-3D / 4-5D

Channel Rail Adaptor (for Use with Various Channel Rails) Type CRA

Group STAUFF	DIN	Dimensions (mm/in)									Order Codes (Standard Options)
		Thread G	L1	L2	L3	B1	B2	H1	H2	H3	
1D	1	M6	21	35	40	16	19	6	13	20,5	CRA 1-8/1D M W3
		1/4-20 UNC	.83	1.38	1.57	.63	.75	.24	.51	.81	CRA 1-8/1D U W3
2D	2	M8	21	35	38	53	19	9	17	23,5	CRA 2-3D M W3
3D	3	5/16-18 UNC	.83	1.38	1.50	2.09	.75	.35	.67	.93	CRA 2-3D U W3
4D	4	M8	21	35	38	80	19	9	17	23,5	CRA 4-5D M W3
5D	5	5/16-18 UNC	.83	1.38	1.50	3.15	.75	.3	.67	.93	CRA 4-5D U W3

Order Codes

Adaptor

***CRA*1-8/1D*M*W3**

* Channel Rail Adaptor		CRA
* STAUFF Group	1D (DIN Group 1)	1-8/1D
	2D to 3D (DIN Group 2 to 3)	2-3D
	4D to 5D (DIN Group 4 to 5)	4-5D
* Thread code	Metric ISO thread	M
	Unified coarse (UNC) thread	U
* Material code	Carbon Steel, zinc/nickel-plated	W3
	Stainless Steel V4A	W5
	1.4401 / 1.4571 (AISI 316 / 316 Ti)	

The Channel Rail Adaptor, type CRA 1-8/1D is also suitable for Standard Series, STAUFF Group 1 to 8.

All threaded parts are available with Metric ISO thread or unified coarse (UNC) thread according to dimension table. Alternative materials and surface finishings are available upon request. Consult STAUFF for further information.



Compatibility with Channel Rails

The STAUFF Channel Rail Adaptor, type CRA, is suitable for various channel rails, including the following types:

HALFEN	HILTI	UNISTRUT®	STAUFF (Cushion Clamp Series)
HM 41/41	MQ-21, MQ-41, MQ-52, MQ-72	P1000, P1000T, P1000V, P1000VT, P1001	SCS-048-1-PL, SCS-048-1-GR
HZA 41/22	MQ-21U, MQ-41U, MQ-72U	P2000, P2000T	SCS-120-1-PL, SCS-120-1-GR
HZM 41/41	MQ-21D, MQ-41D, MQ-52-72D	P3003, P3003T, P3300V, P3300VT, P3301	See page A83 for technical information.
HZM 41/22		P4000, P4000T	
HL 41/41, HL 41/B2		P5000, P5000T, P5001, P5500, P5500T, P5501	

Consult STAUFF to check compatibility with additional types of channel rails.

Cover Plate Type GD

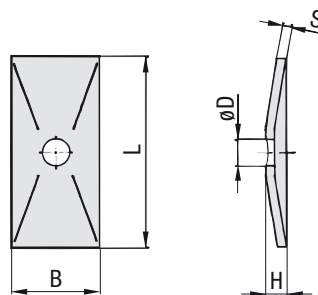
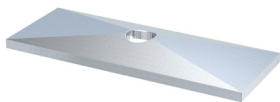

Order Codes

Cover Plate

***GD*1D*W3**

* Cover Plate		GD
* STAUFF Group		1D
* Material code	Carbon Steel, zinc/nickel-plated	W3
	Stainless Steel V2A	W4
	1.4301 / 1.4305 (AISI 304 / 303)	W4
	Stainless Steel V4A	W5
	1.4401 / 1.4571 (AISI 316 / 316 Ti)	W5

Group	STAUFF	DIN	Dimensions (mm/in)				Order Codes (Standard Options)	
			L	B	H	S		ØD
1D	1		34	30	7	3	7	GD 1D W3
			1.34	1.18	.28	.12	.28	
2D	2		52	30	7	3	9	GD 2D W3
			2.05	1.18	.28	.12	.35	
3D	3		65	30	7	3	9	GD 3D W3
			2.56	1.18	.28	.12	.35	
4D	4		79	30	7	3	9	GD 4D W3
			3.11	1.18	.28	.12	.35	
5D	5		102	30	7	3	9	GD 5D W3
			4.02	1.18	.28	.12	.35	

Alternative materials and surface finishings are available upon request. Consult STAUFF for further information.

Hexagon Head Bolt Type AS

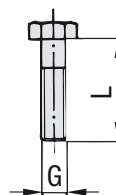

Hexagon Head Bolt AS

(according to DIN 931 / 933 or ANSI / ASME B18.2.1.)

Dimensions applicable only when used with Cover Plate GD

Order Codes

Hexagon Head Bolt

***AS*1D*M*W3**

* Type of bolt	Hexagon Head Bolt (according to DIN 931 / 933 or ANSI / ASME B18.2.1.)	AS
* STAUFF Group		1D
* Thread code	Metric ISO thread	M
	Unified coarse (UNC) thread	U
* Material code	Carbon Steel, zinc/nickel-plated	W3
	Stainless Steel V2A	W4
	1.4301 / 1.4305 (AISI 304 / 303)	W4
	Stainless Steel V4A	W5
	1.4401 / 1.4571 (AISI 316 / 316 Ti)	W5

Group	STAUFF	DIN	Dimensions (mm/in)		Order Codes (Standard Options)
			Thread	G x L	
1D	1		M6 x 35		AS 1D M W3
			1/4-20 UNC x 1-3/8		AS 1D U W3
2D	2		M8 x 35		AS 2D M W3
			5/16-18 UNC x 1-3/8		AS 2D U W3
3D	3		M8 x 45		AS 3D M W3
			5/16-18 UNC x 1-3/4		AS 3D U W3
4D	4		M8 x 50		AS 4D M W3
			5/16-18 UNC x 2		AS 4D U W3
5D	5		M8 x 60		AS 5D M W3
			5/16-18 UNC x 2-1/2		AS 5D U W3

All threaded parts are available with Metric ISO thread or unified coarse (UNC) thread according to dimension table. Alternative materials and surface finishings are available upon request. Consult STAUFF for further information.

Safety Locking Plate

(for Use with Stacking Bolt AF) **Type SI**

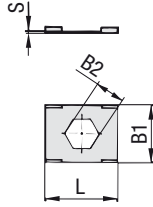
Safety Locking Plate SI

Group STAUFF	DIN	Dimensions (mm/in)				Order Codes (Standard Options)
		L	B	S	H	
1D	1	27	22	11,2	0,5	SI 1D W3
		1.06	.86	.44	.02	
2D	2	27	22	12,2	0,5	SI 2-5D W3
3D	3					
4D	4					
5D	5					
		1.06	.86	.48	.02	

Order Codes

Safety Locking Plate ***SI*1D*W3**

* Safety Locking Plate	SI
* STAUFF Group	1D
1D (DIN Group 1)	2-5D
2D to 5D (DIN Group 2 to 5)	W3
* Material code	W3
Carbon Steel, zinc/nickel-plated	W4
Stainless Steel V2A	W5
1.4301 / 1.4305 (AISI 304 / 303)	
Stainless Steel V4A	
1.4401 / 1.4571 (AISI 316 / 316 Ti)	

Alternative materials and surface finishings are available upon request. Consult STAUFF for further information.

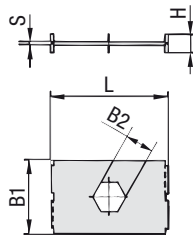

Safety Locking Plate

(for Use with Stacking Bolt AF) **Type SIV**

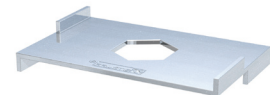
Safety Locking Plate SIV
(Prevents Upper Clamp from Turning)

Group STAUFF	DIN	Dimensions (mm/in)					Order Codes (Standard Options)
		L	B1	B2	S	H	
1D	1	27	28	11,1	1	7	SIV 1D W3
		1.06	1.10	.44	.04	.27	
2D	2	45	28	11,1	1	7	SIV 2-3D W3
3D	3						

Order Codes

Safety Locking Plate ***SIV*1D*W3**

* Safety Locking Plate	SIV
* STAUFF Group	1D
1D (DIN Group 1)	2-3D
2D to 3D (DIN Group 2 to 3)	W3
* Material code	W3
Carbon Steel, zinc/nickel-plated	W4
Stainless Steel V2A	W5
1.4301 / 1.4305 (AISI 304 / 303)	
Stainless Steel V4A	
1.4401 / 1.4571 (AISI 316 / 316 Ti)	

Alternative materials and surface finishings are available upon request. Consult STAUFF for further information.

Stacking Bolt

Type AF (for Use with Safety Locking Plates SI / SIV)

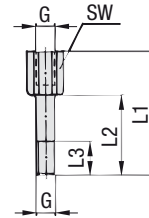

Order Codes		Dimensions (mm / in)					Order Codes (Standard Options)
STAUFF	DIN	Thread G	L1	L2	L3 min.	Hex	
Stacking Bolt	*AF*1D*M*W3	M6	34	20	12	11	AF 1D M W3
		1/4-20 UNC	1.33	.78	.47	.43	AF 1D U W3
* Stacking Bolt	AF						
* STAUFF Group	1D						
* Thread code	Metric ISO thread	M					
	Unified coarse (UNC) thread	U					
* Material code	Carbon Steel, zinc/nickel-plated	W3					
	Stainless Steel V2A	W4					
	1.4301 / 1.4305 (AISI 304 / 303)	W4					
	Stainless Steel V4A	W5					
	1.4401 / 1.4571 (AISI 316 / 316 Ti)	W5					
2D	2	M8	33	20	12	12	AF 2D M W3
		5/16-18 UNC	1.30	.78	.47	.47	AF 2D U W3
3D	3	M8	44	29	12	12	AF 3D M W3
		5/16-18 UNC	1.73	1.14	.47	.47	AF 3D U W3
4D	4	M8	49	34	12	12	AF 4D M W3
		5/16-18 UNC	1.92	1.33	.47	.47	AF 4D U W3
5D	5	M8	61	46	12	12	AF 5D M W3
		5/16-18 UNC	2.40	1.81	.47	.47	AF 5D U W3

All threaded parts are available with Metric ISO thread or unified coarse (UNC) thread according to dimension table. Alternative materials and surface finishings are available upon request. Consult STAUFF for further information.



Please see page A48 with detailed order examples for some of the most popular Twin Series clamp assemblies.

① Type of Installation

Please select the type of installation (e.g. weld plates, rail nuts, etc.) and add the corresponding Code to position ① of the order code for your clamp assembly.

Without Installation Equipment
Code: **none**

Installation on Weld Plate

Single Weld Plate
Code: **SP**

Group Weld Plate
Code: **RAP**

Installation on Mounting / Channel Rail

Mounting Rail Nut
Code: **SM**

Channel Rail Adaptor
Code: **CRA**

③ Clamp Body Design & Material

Please select the design and material of your clamp body and add the corresponding Code to position ③ of the order code for your clamp assembly.

Please check the availability of the selected clamp body design and material according to the matrix table in ②.

Profiled Design

Polypropylene
Code: **PP**

Polyamide
Code: **PA**

Type H (Smooth)

Polypropylene
Code: **PPH**

Polyamide
Code: **PAH**

⑤ Thread Type

Please select the required thread type and add the corresponding Code to position ⑤ of the order code for your clamp assembly.

Metric ISO thread
Code: **M**

Unified coarse (UNC) thread
Code: **U**

All threaded parts are available with Metric ISO thread or unified coarse (UNC) thread according to dimension table.

⑥ Material & Surface Finishing

Please select the required material & surface finishing of the metal parts and add the corresponding Code to position ⑥ of the order code for your clamp assembly.

Metal parts made of Carbon Steel, untreated **W1**

Metal parts made of Carbon Steel, phosphated **W2**

Metal parts made of Carbon Steel, zinc/nickel-plated **W3**

Metal parts made of Stainless Steel V2A
1.4301 / 1.4305 (AISI 304 / 303) **W4**

Metal parts made of Stainless Steel V4A
1.4401 / 1.4571 (AISI 316 / 316 Ti) **W5**

Weld Plate made of Carbon Steel, phosphated; Other metal parts made of Carbon Steel, zinc/nickel-plated **W10**

Rail Nut made of Carbon Steel, untreated; Other metal parts made of Carbon Steel, zinc/nickel-plated **W11**

Individual combinations of alternative materials and surface finishings are available upon request. Consult STAUFF for further information.

② Group Size & Diameters

Please select the required group size and diameter and add the corresponding Code to position ② of the order code for your clamp assembly.

Group STAUFF (DIN)	Outside Diameter P / T / H (mm)	Availability of Clamp Body Materials & Designs		Code
		Profiled Design	Type H	
1D (1)	6	●	●	106/06
	6,4	●	●	106,4/06,4
	8	●	●	108/08
	9,5	●	●	109,5/09,5
	10	●	●	110/10
	12	●	●	112/12
2D (2)	12,7	●	●	212,7/12,7
	13,5	●	●	213,5/13,5
	14	●	●	214/14
	15	●	●	215/15
	16	●	●	216/16
	17,2	●	●	217,2/17,2
3D (3)	18	●	●	218/18
	19	●	●	319/19
	20	●	●	320/20
	21,3	●	●	321,3/21,3
	22	●	●	322/22
	25	●	●	325/25
4D (4)	25,4	●	●	325,4/25,4
	26,9	●	●	426,9/26,9
	28	●	●	428/28
5D (5)	30	●	●	430/30
	32	●	●	532/32
	33,7	●	●	533,7/33,7
	35	●	●	535/35
	38	●	●	538/38
	40	●	●	540/40
	42	●	●	542/42

④ Mounting & Fitting Combination

Please select the mounting and fitting combination (e.g. Bolts, Cover Plates, etc.) and add the corresponding Code to position ④ of the order code for your clamp assembly.

Installation with Cover Plate and Bolt

**Cover Plate GD with
Hexagon Head Bolt AS**
Code: **GD-AS**

Installation with Locking Plate and Bolt

**Safety Locking Plate SI with
Stacking Bolt AF**
Code: **SI-AF**

● Standard Option

Additional outside diameters and combinations of different outside diameters are available upon request. Please consult STAUFF for further information.

⑦ Assembling & Kitting

If required, please select an additional assembling and kitting option and add the corresponding Code to the last position of the order code for your clamp assembly.

Components supplied separately
Code: **none** (standard option)

Components assembled
Code: **#A** (special option)

Components packed in kits
Code: **#K** (special option)

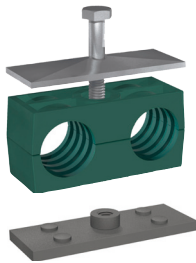

- 1x **Hexagon Head Bolt**
Surface: W3
Thread: Metric
- 1x **Cover Plate**
Surface: W3
- 1x **Clamp Body** (two halves)
STAUFF Group 1D (DIN 1)
both O.D. 6 mm / .24 in
Material: Polypropylene
Profiled inside surface
with tension clearance
- 1x **Weld Plate**
Surface: W2
Thread: Metric

Order Code

SP 106/06 PP GD-AS M W10

W10 is the standard option for this type of installation.

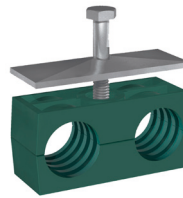

- 1x **Hexagon Head Bolt**
Surface: W3
Thread: Metric
- 1x **Cover Plate**
Surface: W3
- 1x **Clamp Body** (two halves)
STAUFF Group 1D (DIN 1)
both O.D. 6 mm / .24 in
Material: Polypropylene
Profiled inside surface
with tension clearance

Order Code

106/06 PP GD-AS M W3

W3 is the standard option for this type of installation.



- 1x **Stacking Bolt**
Surface: W3
Thread: Metric
- 1x **Safety Locking Plate (Type SI)**
Surface: W3
Thread: Metric
- 1x **Clamp Body** (two halves)
STAUFF Group 1D (DIN 1)
both O.D. 6 mm / .24 in
Material: Polypropylene
Profiled inside surface
with tension clearance

Order Code

106/06 PP SI-AF M W3

W3 is the standard option for this type of installation.

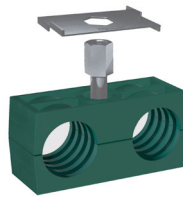

- 1x **Stacking Bolt**
Surface: W3
Thread: Metric
- 1x **Safety Locking Plate (Type SIV)**
Surface: W3
Thread: Metric
- 1x **Clamp Body** (two halves)
STAUFF Group 1D (DIN 1)
both O.D. 6 mm / .24 in
Material: Polypropylene
Profiled inside surface
with tension clearance

Order Code

106/06 PP SIV-AF M W3

W3 is the standard option for this type of installation.
This type of installation is available up to STAUFF Group 3D only.

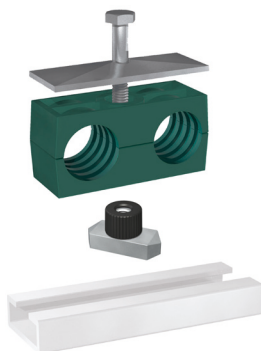

- 1x **Hexagon Head Bolt**
Surface: W3
Thread: Metric
- 1x **Cover Plate**
Surface: W3
- 1x **Clamp Body** (two halves)
STAUFF Group 1D (DIN 1)
both O.D. 6 mm / .24 in
Material: Polypropylene
Profiled inside surface
with tension clearance
- 1x **Hexagon Rail Nut**
Surface: W1
Thread: Metric

Order Code (Mounting Rail TS not included.)

SM 106/06 PP GD-AS M W11

W11 (STAUFF Group 1D) and W3 (STAUFF Group 2D to 5D) are the standard options for this type of installation.

Thread Codes

All threaded parts are available with Metric ISO thread or unified coarse (UNC) thread according to dimension table.

Metric ISO thread	M
Unified coarse (UNC) thread	U

Material Codes

The below listed material codes describe the materials and surface finishings of metal parts that are most relevant for Twin Series clamp assemblies. Individual combinations of alternative materials and surface finishings are available upon request. Consult STAUFF for further information.

Metal parts made of Carbon Steel, untreated	W1
Metal parts made of Carbon Steel, phosphated	W2
Metal parts made of Carbon Steel, zinc/nickel-plated	W3
Metal parts made of Stainless Steel V2A: 1.4301 / 1.4305 (AISI 304 / 303)	W4
Metal parts made of Stainless Steel V4A: 1.4401 / 1.4571 (AISI 316 / 316 Ti)	W5
Weld Plate made of Carbon Steel, phosphated;	W10
Other metal parts made of Carbon Steel, zinc/nickel-plated	W10
Rail Nut made of Carbon Steel, untreated;	W11
Other metal parts made of Carbon Steel, zinc/nickel-plated	W11

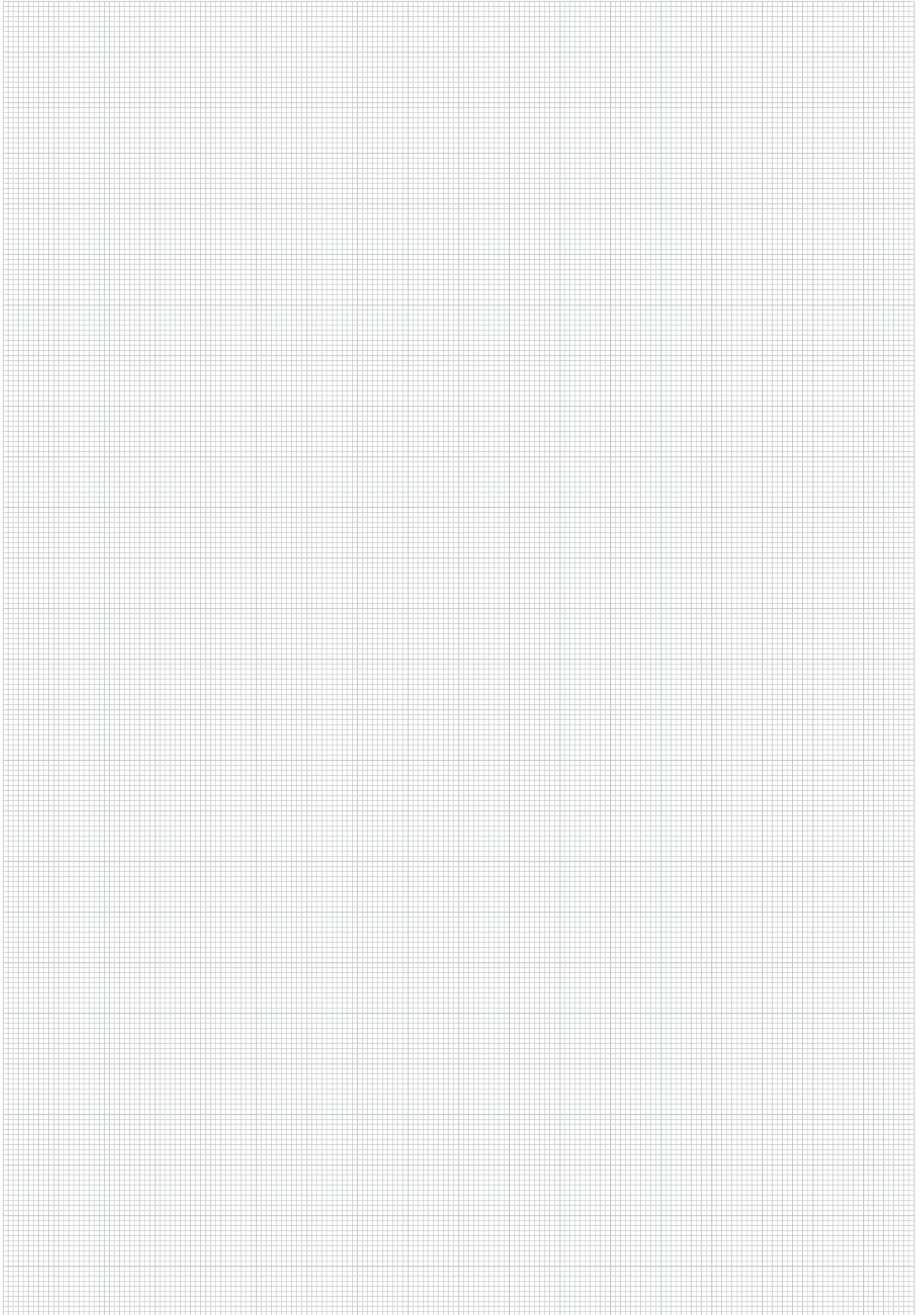

Clamp Body - Profiled Design

Profiled Inside Surface with Tension Clearance

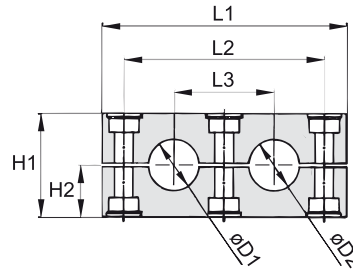
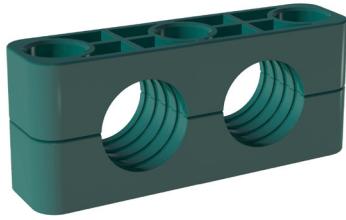

Order Codes

Clamp Body *4*012,7/12,7*PP

One clamp body is consisting of two clamp halves.

- * 1st part of STAUFF Group **4**
- * Exact outside diameters Ø D1 / Ø D2 (mm) **012,7/12,7**
- * Material code (see below) **PP**

Standard Materials



Polypropylene
Colour: Green
Material code: **PP**



Polyamide
Colour: Black
Material code: **PA**

See page A86 for material properties and technical information.

Group	Outside Diameter		Nominal Bore	Copper Tube	Order Codes (2 Clamp Halves)	Dimensions (mm/in)					
	Pipe / Tube	Ø D1 / Ø D2				Pipe	Tube	L1	L2	L3	H1
STAUFF	12,7	1/2		3/8	4012,7/12,7 **						
	19	3/4			4019/19 **						
	20				4020/20 **						
	21,3		1/2		4021,3/21,3 **						
	22			3/4	4022/22 **						
	25,4	1			4025,4/25,4 **						
4S-D	26,9		3/4		4026,9/26,9 **						
	32	1-1/4			5032/32 **						
	33,7		1		5033,7/33,7 **	115	90	45	48	24	30
	38	1-1/2			5038/38 **	4.53	3.54	1.77	1.89	0.94	1.18
	42		1-1/4		5042/42 **						
	5S-D										

Additional outside diameters and Clamp Bodies, type H (smooth inside surface without tension clearance) are available upon request. Please consult STAUFF for further information.

Clamp Body with Rubber Inserts Type RI

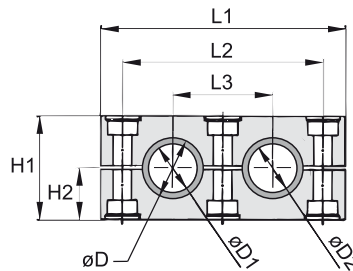

For use with Rubber Inserts of the Heavy Series, STAUFF Group 4S and 5S (see page A27 for details)

Order Codes

Clamp Assembly *4*006/06*PPR

One assembly is consisting of one clamp body and two inserts.

- * 1st part of STAUFF Group **4**
- * Exact outside diameters Ø D1 / Ø D2 (mm) **006/06**
- * Material code (see below) **PPR**

Standard Materials



Polypropylene
Colour: Black
Material code: **PPR**



Polyamide
Colour: Black
Material code: **PAR**



Rubber Inserts
Thermoplastic Elastomer (73 Shore-A)
Colour: Black

See page A86 for properties and technical information.

Group	Outside Diameter		Order Codes (Clamp Assembly)	Dimensions (mm/in)						
	Pipe / Tube / Hose	Ø D1 / Ø D2		Ø D	L1	L2	L3	H1	H2	Width
STAUFF	6		4006/06 **R							
	8	5/16	4008/08 **R							
	10		4010/10 **R							
	12		4012/12 **R							
	12,7	1/2	4012,7/12,7 **R							
	14		4014/14 **R							
	15		4015/15 **R							
	16	5/8	4016/16 **R							
	17,2		4017,2/17,2 **R							
	18		4018/18 **R							
4S-D	19	3/4	4019/19 **R							
	20		5020/20 **R							
	21,3		5021,3/21,3 **R	25	115	90	45	48	24	30
	22	7/8	5022/22 **R	.98	4.53	3.54	1.77	1.89	0.94	1.18
	25		5025/25 **R							
	26,9		5026,9/26,9 **R							
	28		5028/28 **R							
	30		5030/30 **R							
	32	1-1/4	5032/32 **R							
	5S-D				1.50	5.71	4.72	2.36	2.36	1.18

Additional outside diameters are available upon request. Please consult STAUFF for further information.

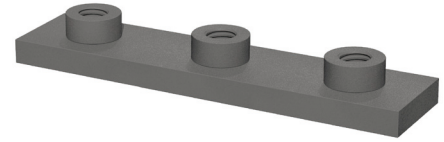
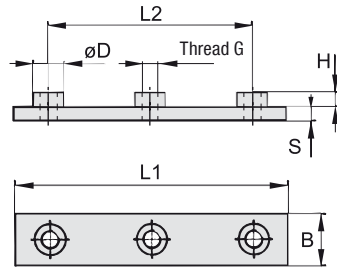
**Weld Plate
Type SPAD**

Group STAUFF	Dimensions (mm/in)							Order Codes (Standard Options)
	L1	L2	B	S	H	Thread G	ØD	
4S-D	115	90	30	8	8,5	M10	18	SPAD 4S M W1
	4.53	3.54	1.18	.31	.33	3/8-16 UNC	.71	SPAD 4S U W2*
5S-D	145	120	30	8	8,5	M10	18	SPAD 5S M W1
	5.71	4.72	1.18	.31	.33	3/8-16 UNC	.71	SPAD 5S U W2*

All threaded parts are available with Metric ISO thread or unified Coarse (UNC) thread according to dimension table. Alternative materials and surface finishings are available upon request. Consult STAUFF for further information.

* Standard finishing option in North America is W2 (Carbon Steel, phosphated).

Order Codes
Weld Plate
***SPAD*4S*M*W1**

* Weld Plate		SPAD
* STAUFF Group	4S-D	4S
	5S-D	5S
* Thread code	Metric ISO thread	M
	Unified coarse (UNC) thread	U
* Material code	Carbon Steel, untreated	W1
	Carbon Steel, phosphated	W2
	Carbon Steel, zinc/nickel-plated	W3
	Stainless Steel V2A	W4
	1.4301 / 1.4305 (AISI 304 / 303)	W4
	Stainless Steel V4A	W5
	1.4401 / 1.4571 (AISI 316 / 316 Ti)	W5

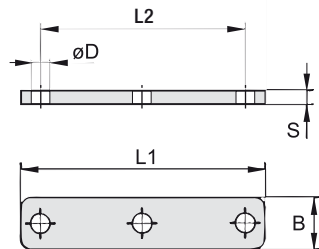
**Cover Plate
Type DPAD**

Group STAUFF	Dimensions (mm/in)					Order Codes (Standard Options)
	L1	L2	B	S	ØD	
4S	115	90	30	8	11	DPAD 4S W1
	4.53	3.54	1.18	.31	.43	DPAD 4S W2*
5S	145	120	30	8	11	DPAD 5S W1
	5.71	4.72	1.18	.31	.43	DPAD 5S W2*

All threaded parts are available with Metric ISO thread or unified Coarse (UNC) thread according to dimension table. Alternative materials and surface finishings are available upon request. Consult STAUFF for further information.

* Standard finishing option in North America is W2 (Carbon Steel, phosphated).

Order Codes
Cover Plate
***DPAD*4S*W1**

* Cover Plate		DPAD
* STAUFF Group	4S-D	4S
	5S-D	5S
* Material code	Carbon Steel, untreated	W1
	Carbon Steel, phosphated	W2
	Carbon Steel, zinc/nickel-plated	W3
	Stainless Steel V2A	W4
	1.4301 / 1.4305 (AISI 304 / 303)	W4
	Stainless Steel V4A	W5
	1.4401 / 1.4571 (AISI 316 / 316 Ti)	W5

**Hexagon Head Bolt
Type AS**

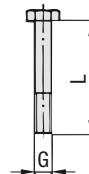

Hexagon Head Bolt AS

(according to DIN 931 / 933 or ANSI / ASME B18.2.1.)
Dimensions applicable only when used with Cover Plate DPAD

Order Codes	
Hexagon Head Bolt	*AS*4S*M*W1
* Type of bolt	Hexagon Head Bolt (according to DIN 931 / 933 or ANSI / ASME B18.2.1.) AS
* STAUFF Group	4S-D 4S 5S-D 5S
* Thread code	Metric ISO thread M Unified coarse (UNC) thread U
* Material code	Carbon Steel, untreated W1 Carbon Steel, zinc/nickel-plated W3 Stainless Steel V2A W4 1.4301 / 1.4305 (AISI 304 / 303) W4 Stainless Steel V4A W5 1.4401 / 1.4571 (AISI 316 / 316 Ti) W5

Group STAUFF	DIN	Dimensions (mm / in) Thread G x L	Order Codes (Standard Options)
4S	2	M10 x 60	AS 4S M W1
		3/8-16 UNC x 2-1/4	AS 4S U W3*
5S	3	M10 x 70	AS 5S M W1
		3/8-16 UNC x 2-3/4	AS 5S U W3*

All threaded parts are available with Metric ISO thread or unified coarse (UNC) thread according to dimension table. Alternative materials and surface finishings are available upon request. Consult STAUFF for further information.

If required, use Safety Washers, type SI as locking devices to prevent Hexagon Head Bolts, type AS from loosening. See page A34 for details.

* Standard finishing option in North America is W3 (Carbon Steel, zinc/nickel-plated).

Further Metal Hardware

For Use with the Heavy Twin Series



**Mounting Rail Nut
Type GMV**

Heavy Series, STAUFF Group 4S and 5S
(See page A30 for details)



**Mounting Rail
Type STSV**

Heavy Series
(See page A30 for details)

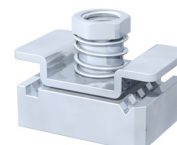

**Channel Rail Adaptor
Type CRA**

Heavy Series, STAUFF Group 4S and 5S
(See page A31 for details)



**Socket Cap Screw
Type IS**

Heavy Series, STAUFF Group 4S and 5S
(See page A33 for details)

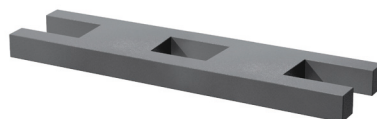

**Safety Locking Plate
Type SIPD**

Heavy Twin Series, STAUFF Group 4S-D and 5S-D
(Consult STAUFF for details)



**Stacking Bolt
Type AF**

Heavy Series, STAUFF Group 4S and 5S
(See page A34 for details)



① Type of Installation

Please select the type of installation (e.g. Weld Plates, Rail Nuts, etc.) and add the corresponding Code to position ① of the order code for your clamp assembly.

Without Installation Equipment
Code: **none**

Installation on Weld Plate

Single Weld Plate
Code: **SPAD**

Installation on Mounting / Channel Rail

Mounting Rail Nut
Code: **GMV**

Channel Rail Adaptor
Code: **CRA**

② Group Size & Diameters

Please select the required group size and diameter and add the corresponding Code to position ② of the order code for your clamp assembly.

Group	Outside Diameter P / T / H (mm)	Availability of Clamp Body Materials & Designs		Code
		Profiled Design	Type RI	
4S-D	6	○	●	4006/06
	8	○	●	4008/08
	10	○	●	4010/10
	12	○	●	4012/12
	12,7	●	●	4012,7/12,7
	14	○	●	4014/14
	15	○	●	4015/15
	16	○	●	4016/16
	17,2	○	●	4017,2/17,2
	18	○	●	4018/18
	19	●	●	4019/19
	20	●	○	4020/20
	21,3	●	○	4021,3/21,3
	22	●	○	4022/22
	25,4	●	○	4025,4/25,4
26,9	●	○	4026,9/26,9	
5S-D	20	○	●	5020/20
	21,3	○	●	5021,3/21,3
	22	○	●	5022/22
	25	○	●	5025/25
	26,9	○	●	5026,9/26,9
	28	○	●	5028/28
	30	○	●	5030/30
	32	●	●	5032/32
	33,7	●	○	5033,7/33,7
	38	●	○	5038/38
42	●	○	5042/42	

● Standard Option

Additional outside diameters and combinations of different outside diameters are available upon request. Please consult STAUFF for further information.

③ Clamp Body Design & Material

Please select the design and material of your clamp body and add the corresponding Code to position ③ of the order code for your clamp assembly.

Please check the availability of the selected clamp body design and material according to the matrix table in ②.

Profiled Design

Polypropylene
Code: **PP**

Polyamide
Code: **PA**

Type RI (with Rubber Insert)

Polypropylene
Code: **PPR**

Polyamide
Code: **PAR**

Clamp Bodies, Type H (smooth Inside surface without tension clearance) are available upon request. Please consult STAUFF for further information.

④ Mounting & Fitting Combination

Please select the mounting and fitting combination (e.g. Bolts, Cover Plates, etc.) and add the corresponding Code to position ④ of the order code for your clamp assembly.

Installation with Cover Plate and Bolts

Cover Plate DPAD with Hexagon Head Bolt AS
Code: **DPAD-AS**

Installation with Locking Plate and Bolts

Safety Locking Plate SIPD with Stacking Bolt AF
Code: **SIPD-AF**

⑤ Thread Type

Please select the required thread type and add the corresponding Code to position ⑤ of the order code for your clamp assembly.

Metric ISO thread
Code: **M**

Unified coarse (UNC) thread
Code: **U**

All threaded parts are available with Metric ISO thread or unified coarse (UNC) thread according to dimension table.

⑥ Material & Surface Finishing

Please select the required material & surface finishing of the metal parts and add the corresponding Code to position ⑥ of the order code for your clamp assembly.

Metal parts made of Carbon Steel, untreated **W1**

Metal parts made of Carbon Steel, phosphated **W2**

Metal parts made of Carbon Steel, zinc/nickel-plated **W3**

Metal parts made of Stainless Steel V2A 1.4301 / 1.4305 (AISI 304 / 303) **W4**

Metal parts made of Stainless Steel V4A 1.4401 / 1.4571 (AISI 316 / 316 Ti) **W5**

Weld Plate made of Carbon Steel, phosphated; Other metal parts made of Carbon Steel, zinc/nickel-plated **W10**

Weld Plate and Cover Plate made of Carbon Steel, phosphated; Bolts made of Carbon Steel, untreated **W12**

Mounting Rail Nuts made of Carbon Steel, zinc/nickel-plated; Cover Plate made of Carbon Steel, phosphated; Bolts made of Carbon Steel, untreated **W13**

Weld Plate / Cover Plate made of Carbon Steel, phosphated; Bolts made of Carbon Steel, zinc/nickel-plated **W15**

Mounting Rail Nuts made of Carbon Steel, zinc/nickel-plated; Cover Plate made of Carbon Steel, phosphated; Bolts made of Carbon Steel, zinc/nickel-plated **W16**

Safety Locking Plate made of Carbon Steel, phosphated; Bolts made of Carbon Steel, zinc/nickel-plated **W17**

Safety Locking Plate made of Carbon Steel, untreated; Bolts made of Carbon Steel, phosphated **W18**

Cover Plate made of Carbon Steel, phosphated; Bolts made of Carbon Steel, untreated **W19**

Individual combinations of alternative materials and surface finishings are available upon request. Consult STAUFF for further information.

⑦ Assembling & Kitting

If required, please select an additional assembling and kitting option and add the corresponding Code to the last position of the order code for your clamp assembly.

Components Supplied Separately
Code: **none** (Standard Option)

Components Assembled
Code: **#A** (Special Option)

Components Packed in Kits
Code: **#K** (Special Option)

Compact Twin Series: Clamp Body Type DS

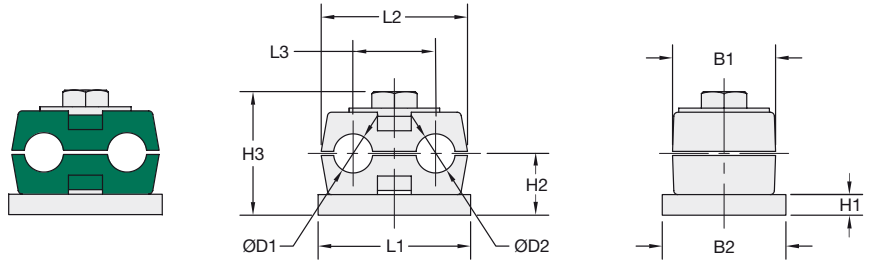

Order Codes

Clamp Body

***DS1*06/06*PP**

One clamp body is consisting of two clamp halves.

- * Compact Twin Series, STAUFF Group 1 **DS 1**
- * Exact outside diameters Ø D1 / Ø D2 (mm) **06/06**
- * Clamp Body Material (Polypropylene) **PP**

Group	Outside Diameter Pipe / Tube Ø D1 / Ø D2		Nominal Bore Pipe (in)	Copper Tube (in)	Order Codes (2 Clamp Halves)	Dimensions (mm/in)								
	(mm)	(in)				L1	L2	L3	H1	H2	H3	B1	B2	
DS 1	6				DS106/06 PP									
	6,4	1/4			DS106,4/06,4 PP									
	8	5/16			DS108/08 PP	37	35,5	20	5	15	30	25	30	
	9,5	3/8		1/4	DS109,5/09,5 PP	1.46	1.40	.79	.20	.59	1.18	.98	1.18	
	10		1/8		DS110/10 PP									

Additional outside diameters are available upon request. Please consult STAUFF for further information.

Compact Twin Series: Metal Hardware

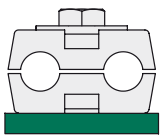

Weld Plate, Type SP DS1

SP DS1 U W2 (unified coarse thread)
Thread size: 1/4–20 UNC
Made of Carbon Steel, phosphated

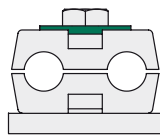

Cover Plate, Type US DS1

US DS1 W3
Made of Carbon Steel, zn/ni-plated

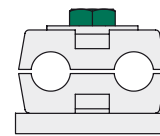

Hexagon Bolt, Type AS DS1

AS DS1 U W3 (unified coarse thread)
Bolt size: 1/4–20 UNC x 1
Made of Carbon Steel, zn/ni-plated

All threaded parts are only available with unified coarse (UNC) thread.
Rail mount and stacking assemblies as well as alternative materials and surface finishings are available upon request.
Consult STAUFF for further information.

Agriculture Twin Series: Clamp Body Type AG

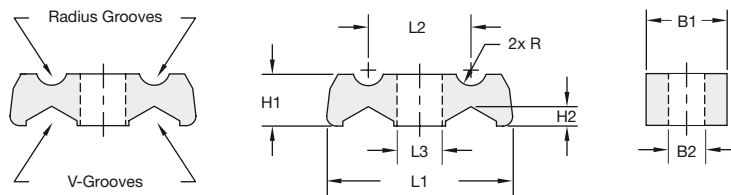

Order Codes

Clamp Body

***AG*2**

- * Agriculture Twin Series **AG 2**
- * STAUFF Group **2**

Group	Min/Max Outside Diameters Pipe / Tube				Order Codes (1 Clamp Body)	Dimensions (mm/in)							
	using Radius Grooves (mm) (in)		using V-Grooves (mm) (in)			L1	L2	L3	H1	H2	B1	B2	R
2	3 ... 10	.1239	4 ... 15	.2659	AG 2	57,5	31,7	14,0	16,0	7,1	25,0	11,0	4,8
						2.26	1.25	.55	.63	.24	.98	.43	.19
3	4 ... 25	.1698	7 ... 20	.2879	AG 3	62,0	34,5	14,0	19,0	7,1	32,0	11,0	12,4
						2.48	1.36	.55	.75	.28	1.26	.43	.49

Standard Material



Polypropylene
Colour: Black

See page A86 for properties and technical information.

Additional outside diameters are available upon request. Please consult STAUFF for further information.

Product Features

- Flip the clamp body to choose between the radius grooved or the v-grooved design (suitable for a range of diameters)
- Use M10 or 3/8–16 UNC bolts or screws (preferably with washers) to fasten clamp bodies directly to the machine
- Clamp bodies can be stacked for multi-level assembly

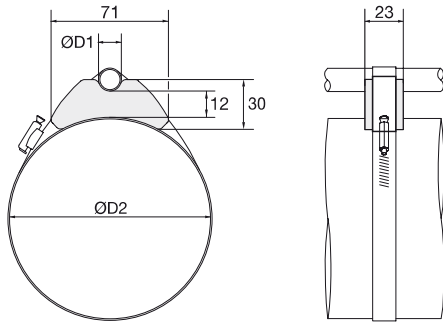

Saddle Clamp for Cylinder Supply Lines Type ZR 518



Min/Max Outside Diameters Pipe / Tube				Steel Strap Dimensions (Not Included in Scope of Delivery)			
Ø D1		Ø D2		Length		Width	
(mm)	(in)	(mm)	(in)	(mm)	(in)	(mm)	(in)
10 ... 22	.3987	50 ... 70	1.96 ... 2.76	196 ... 254	7.71 ... 10.00	13	.51
		60 ... 80	2.36 ... 3.15	225 ... 284	8.86 ... 11.18		
		70 ... 90	2.76 ... 3.54	254 ... 314	10.00 ... 12.36		
		80 ... 105	3.15 ... 4.13	284 ... 359	11.18 ... 14.13		
		90 ... 120	3.54 ... 4.72	314 ... 404	12.36 ... 15.90		
		105 ... 140	4.13 ... 5.51	359 ... 464	14.13 ... 18.27		
		125 ... 160	4.92 ... 6.30	419 ... 525	16.50 ... 20.66		
		145 ... 180	5.71 ... 7.09	479 ... 586	18.86 ... 23.07		
165 ... 200	6.50 ... 7.87	540 ... 647	21.26 ... 25.47				

Order Code

Saddle Clamp ZR 518 Black 9005

Standard Material



Thermoplastic Elastomer (75±5 Shore-A)
Colour: Black

See page A86 for properties and technical information.



Custom-Designed Plastic Saddle Clamps

Custom-designed Plastic Saddle Clamps according to customer's specifications or based on STAUFF developments are available upon request.

Consult STAUFF for further information.

Machined Versions

Custom-designed clamping systems for pipes, tubes, hoses, cables and other components according to customer's specifications or based on STAUFF developments, made of thermoplastics, metals and non-ferrous metals.

Accessories such as weld plates, cover plates, bolts as well as rubber inserts are available on request.

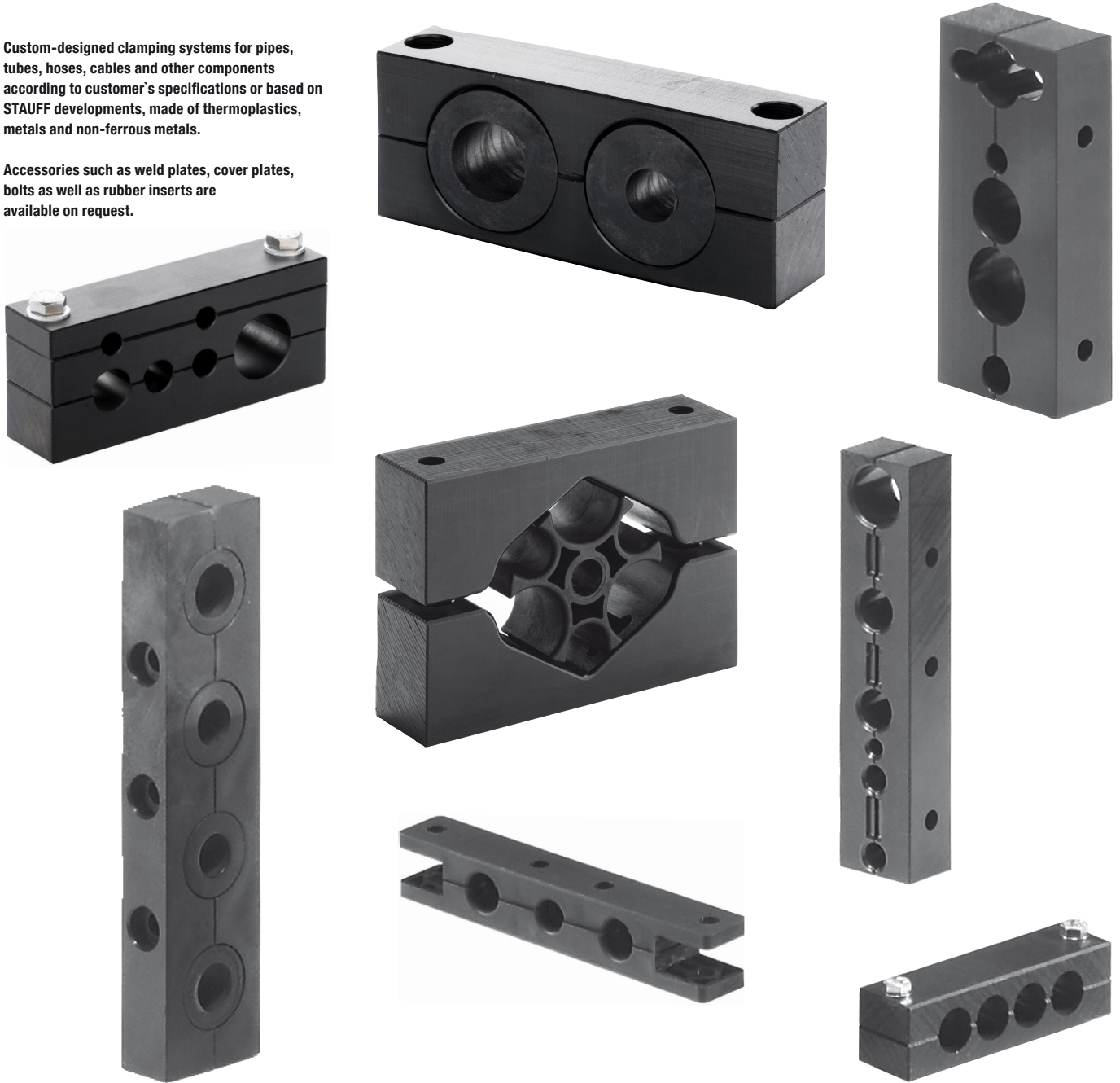

www.stauff.com/configurator

Online Configurator for Custom-Designed Clamps

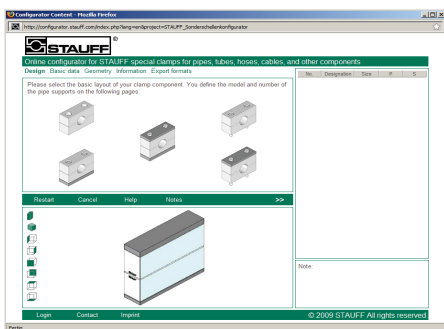

Select the basic design of your clamp assembly.

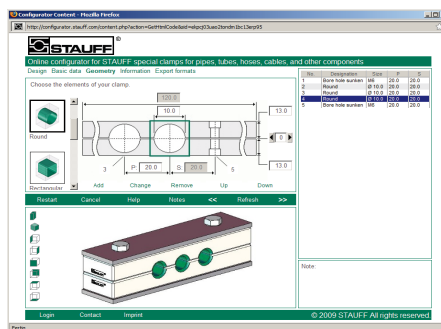

Define the exact geometry of your clamp body.

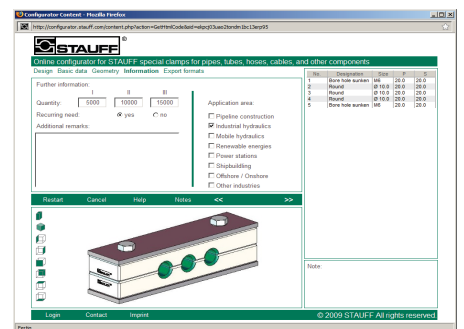

Request a quotation and download 2D or 3D CAD file.

Injection Moulded Versions (Flexi Clamps)

Custom-designed clamping systems for pipes, tubes, hoses, cables and other components according to customer's specifications or based on STAUFF developments, made of Polypropylene, Polyamide and other thermoplastics.

Accessories such as weld plates, cover plates, bolts as well as rubber inserts are available on request.

STAUFF
Clamps
A



Clamp Body - Single Design

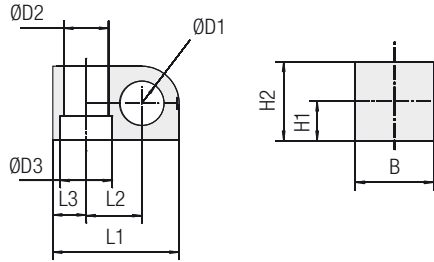

Order Codes

Clamp Body *LBBU*1*06*SA*M8-U5/16

- * Light Series LBBU **LBBU**
- * STAUFF Group **1**
- * Exact outside diameter Ø D1 (mm) **06**
- * Material code (see below) **SA**
- * Thread code (suitable for bolts M8 and U5/16) **M8-U5/16**

Standard Materials



Thermoplastic Elastomer (87 Shore-A)
 Colour: Black
 Material code: **SA**

See page A86 for material properties and technical information.

Alternative materials are available upon request.
 Please consult STAUFF for further information.

Product Features

- Compact and light-weight design for applications in which space is limited
- Available in 3 different sizes and covering all standard metric and imperial diameters between 4 mm and 32 mm
- Vibration-damping and noise-reducing clamp body material with UV, ozone and weathering-resistant characteristics
- Advanced design with a film hinge allows the top part of the Plastic clamp body to open up and insert or replace the pipe, tube or hose without the use of force
- Embedded metal sleeve to ensure stability of the clamp assembly

Group	Outside Diameter Pipe / Tube / Hose Ø D1		Nominal Bore Pipe (in)	Order Codes (1 Clamp Body)	Dimensions (mm/in)										
	(mm)	(in)			Ø D2	Ø D3	L1	L2	L3	H1	H2	B			
1	6			LBBU 106 SA M8-U5/16											
	6,4	1/4		LBBU 106,4 SA M8-U5/16											
	8	5/16		LBBU 108 SA M8-U5/16											
	9,5	3/8		LBBU 109,5 SA M8-U5/16	12	14	34	15	9	10	20	20			
	10		1/8	LBBU 110 SA M8-U5/16	.47	.55	1.34	.59	.35	.39	.79	.79			
	11			LBBU 111 SA M8-U5/16											
	12			LBBU 112 SA M8-U5/16											
	12,7	1/2		LBBU 112,7 SA M8-U5/16											
	2	4			LBBU 204 SA M8-U5/16										
		6			LBBU 206 SA M8-U5/16										
6,4		1/4		LBBU 206,4 SA M8-U5/16											
8		5/16		LBBU 208 SA M8-U5/16											
9,5		3/8		LBBU 209,5 SA M8-U5/16											
10			1/8	LBBU 210 SA M8-U5/16											
11				LBBU 211 SA M8-U5/16											
12				LBBU 212 SA M8-U5/16	12	14	39	18	9	12	24	20			
12,7		1/2		LBBU 212,7 SA M8-U5/16	.47	.55	1.54	.71	.35	.47	.94	.79			
13,5			1/4	LBBU 213,5 SA M8-U5/16											
14				LBBU 214 SA M8-U5/16											
15				LBBU 215 SA M8-U5/16											
16		5/8		LBBU 216 SA M8-U5/16											
17,2		3/8	LBBU 217,2 SA M8-U5/16												
18			LBBU 218 SA M8-U5/16												
19	3/4		LBBU 219 SA M8-U5/16												
20			LBBU 220 SA M8-U5/16												
3	21,3			LBBU 321,3 SA M8-U5/16											
	22	7/8		LBBU 322 SA M8-U5/16											
	23			LBBU 323 SA M8-U5/16											
	25			LBBU 325 SA M8-U5/16	12	14	57,5	23,5	15	20	40	30			
	25,4	1		LBBU 325,4 SA M8-U5/16	.47	.55	2.26	.93	.59	.79	1.57	1.18			
	28			LBBU 328 SA M8-U5/16											
	30			LBBU 330 SA M8-U5/16											
	32	1-1/4		LBBU 332 SA M8-U5/16											

Additional outside diameters are available upon request. Please consult STAUFF for further information.

Light Series LBBU

Clamp Assemblies: Types of Mounting / Order Examples



Type of Mounting SP
(with Weld Plate LBBU-SP)

Clamp assembly consisting of:

- 1 Hexagon Head Bolt AS
- 1 Cover Plate LBBU-DP
- 1 Sleeve LBBU-HUE
- 1 Clamp Body LBBU
- 1 Weld Plate LBBU-SP

Order Code

LBBU-SP 216 SA DP-AS M8 W10

W10 (Weld Plate made of Carbon Steel, phosphated; Other metal parts made of Carbon Steel, zinc/nickel-plated) is the standard option for this type of installation.
 For UNC threads / bolts, please replace M8 by U5/16.



Type of Mounting SM
(with Hexagon Rail Nut SM 2-5D)

Clamp assembly consisting of:

- 1 Hexagon Head Bolt AS
- 1 Cover Plate LBBU-DP
- 1 Sleeve LBBU-HUE
- 1 Clamp Body LBBU
- 1 Hexagon Rail Nut SM 2-5D (for use with Mounting Rail TS, see page A14 for details)

Order Code (Mounting Rail TS not included.)
LBBU-SM 216 SA DP-AS M8 W3

W3 (Metal parts made of Carbon Steel, zinc/nickel-plated) is the standard option for this type of installation.
 For UNC threads / bolts, please replace M8 by U5/16.



Type of Mounting PM
(for panel mounting without Weld Plate or Hexagon Rail Nut)

Clamp assembly consisting of:

- 1 Hexagon Head Bolt AS
- 1 Cover Plate LBBU-DP
- 1 Sleeve LBBU-HUE
- 1 Clamp Body LBBU

Order Code

LBBU-PM 216 SA DP-AS M8 W3

W3 (Metal parts made of Carbon Steel, zinc/nickel-plated) is the standard option for this type of installation.
 For UNC threads / bolts, please replace M8 by U5/16.

Clamp Body - Twin Design

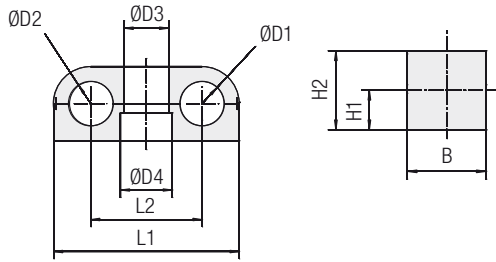

Group	Outside Diameters		Nominal Bore Pipe	Order Codes (1 Clamp Body)	Dimensions (mm/in)						
	Ø D1 / Ø D2	Ø D2			Ø D3	Ø D4	L1	L2	H1	H2	B
1D	4			LBBU 104/04 SA M8-U5/16	12	14	50	30	10	20	20
	6			LBBU 106/06 SA M8-U5/16							
	6,4	1/4		LBBU 106,4/06,4 SA M8-U5/16							
	8	5/16		LBBU 108/08 SA M8-U5/16							
	9,5	3/8		LBBU 109,5/09,5 SA M8-U5/16							
	10		1/8	LBBU 110/10 SA M8-U5/16							
	11			LBBU 111/11 SA M8-U5/16							
	12			LBBU 112/12 SA M8-U5/16							
	12,7	1/2		LBBU 112,7/12,7 SA M8-U5/16							
2D	4			LBBU 204/04 SA M8-U5/16	12	14	59	35	12	24	20
	6			LBBU 206/06 SA M8-U5/16							
	8	5/16		LBBU 208/08 SA M8-U5/16							
	9,5	3/8		LBBU 209,5/9,5 SA M8-U5/16							
	10		1/8	LBBU 210/10 SA M8-U5/16							
	11			LBBU 211/11 SA M8-U5/16							
	12			LBBU 212/12 SA M8-U5/16							
	12,7	1/2		LBBU 212,7/12,7 SA M8-U5/16							
	13,5		1/4	LBBU 213,5/13,5 SA M8-U5/16							
	14			LBBU 214/14 SA M8-U5/16							
	15			LBBU 215/15 SA M8-U5/16							
	16	5/8		LBBU 216/16 SA M8-U5/16							
	17,2		3/8	LBBU 217,2/17,2 SA M8-U5/16							
18			LBBU 218/18 SA M8-U5/16								
19	3/4		LBBU 219/19 SA M8-U5/16								
20			LBBU 220/20 SA M8-U5/16								
3D	21,3			LBBU 321,321,3 SA M8-U5/16	12	14	86	47	20	40	30
	22	7/8		LBBU 322/22 SA M8-U5/16							
	23			LBBU 323/23 SA M8-U5/16							
	25			LBBU 325/25 SA M8-U5/16							
	25,4	1		LBBU 325,4/25,4 SA M8-U5/16							
	28			LBBU 328/28 SA M8-U5/16							
	30			LBBU 330/30 SA M8-U5/16							
	32	1-1/4		LBBU 332/32 SA M8-U5/16							

Order Codes

Clamp Body *LBBU*1*06/06*SA*M8-U5/16

- * Light Series LBBU LBBU
- * 1st Part of STAUFF Group 1
- * Exact outside diameters Ø D1 / Ø D2 (mm) 06/06
- * Material code (see below) SA
- * Thread code (suitable for bolts M8 and U5/16) M8-U5/16

Standard Materials

- Thermoplastic Elastomer** (87 Shore-A)
- Colour: Black
- Material code: **SA**

See page A86 for material properties and technical information.

Alternative materials are available upon request. Please consult STAUFF for further information.

Product Features

- Compact and light-weight design for applications in which space is limited
- Available in 3 different sizes and covering all standard metric and imperial diameters between 4 mm and 32 mm
- Vibration-damping and noise-reducing clamp body material with UV, ozone and weathering-resistant characteristics
- Advanced design with a film hinge allows the top part of the Plastic clamp body to open up and insert or replace the pipe, tube or hose without the use of force
- Embedded metal sleeve to ensure stability of the clamp assembly

 Please also ask for the **Anti-Twist Feature** to prevent turning of the components. Consult STAUFF for further information.

Additional outside diameters and combinations of different outside diameters are available upon request. Please consult STAUFF for further information.

Clamp Assemblies: Types of Mounting / Order Examples

Light Series LBBU

Type of Mounting SP
(with Weld Plate LBBU-SP)

Clamp assembly consisting of:

- 1 Hexagon Head Bolt AS
- 1 Cover Plate LBBU-DP
- 1 Sleeve LBBU-HUE
- 1 Clamp Body LBBU
- 1 Weld Plate LBBU-SP

Order Code
LBBU-SP 216/16 SA DP-AS M8 W10

W10 (Weld Plate made of Carbon Steel, phosphated; Other metal parts made of Carbon Steel, zinc/nickel-plated) is the standard option for this type of installation. For UNC threads / bolts, please replace M8 by U5/16.

Type of Mounting SM
(with Hexagon Rail Nut SM 2-5D)

Clamp assembly consisting of:

- 1 Hexagon Head Bolt AS
- 1 Cover Plate LBBU-DP
- 1 Sleeve LBBU-HUE
- 1 Clamp Body LBBU
- 1 Hexagon Rail Nut SM 2-5D (for use with Mounting Rail TS, see page A14 for details)

Order Code (Mounting Rail TS not included.)
LBBU-SM 216/16 SA DP-AS M8 W3

W3 (Metal parts made of Carbon Steel, zinc/nickel-plated) is the standard option for this type of installation. For UNC threads / bolts, please replace M8 by U5/16.

Type of Mounting PM
(for panel mounting without Weld Plate or Hexagon Rail Nut)

Clamp assembly consisting of:

- 1 Hexagon Head Bolt AS
- 1 Cover Plate LBBU-DP
- 1 Sleeve LBBU-HUE
- 1 Clamp Body LBBU

Order Code
LBBU-PM 216/16 SA DP-AS M8 W3

W3 (Metal parts made of Carbon Steel, zinc/nickel-plated) is the standard option for this type of installation. For UNC threads / bolts, please replace M8 by U5/16.

Weld Plate
Type LBBU-SP

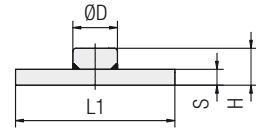
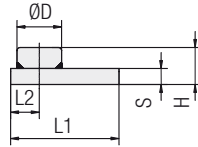

STAUFF Group 1 to 3

STAUFF Group 1D to 3D

Order Codes

Weld Plate *LBBU-SP*1D*M8*W2

- * Light Series LBBU LBBU
- * Weld Plate -SP
- * STAUFF Group 1D
- * Thread code Metric ISO thread: M8 M8
 UNC thread: 5/16-18 UNC U5/16
- * Material code Carbon Steel, phosphated W2

Group STAUFF	Dimensions (mm/in)						Thread G	Order Codes (Standard Options)
	Ø D	L1	L2	H	S			
1	14	34	9	10,3	5	M8	LBBU-SP 1 M8 W2	
	.55	1.34	.35	.41	.20	5/16-18 UNC	LBBU-SP 1 U5/16 W2	
2	14	39	9	10,3	5	M8	LBBU-SP 2 M8 W2	
	.55	1.54	.35	.41	.20	5/16-18 UNC	LBBU-SP 2 U5/16 W2	
3	14	57,5	15	10,3	5	M8	LBBU-SP 3 M8 W2	
	.55	2.26	.59	.41	.20	5/16-18 UNC	LBBU-SP 3 U5/16 W2	
1D	14	50	X	10,3	5	M8	LBBU-SP 1D M8 W2	
	.55	1.97		.41	.20	5/16-18 UNC	LBBU-SP 1D U5/16 W2	
2D	14	59	X	10,3	5	M8	LBBU-SP 2D M8 W2	
	.55	2.32		.41	.20	5/16-18 UNC	LBBU-SP 2D U5/16 W2	
3D	14	86	X	10,3	5	M8	LBBU-SP 3D M8 W2	
	.55	3.39		.41	.20	5/16-18 UNC	LBBU-SP 3D U5/16 W2	



Please also ask for the **Anti-Twist Feature** to prevent turning of the components. Consult STAUFF for further information.

All threaded parts are available with Metric ISO thread or unified coarse (UNC) thread according to dimension table. **Alternative sizes (e.g. for bolts M6 and 1/4-20 UNC), materials and surface finishings are available upon request.**

Sleeve
Type LBBU-HUE

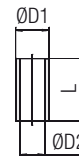

Dimensions applicable only when used with Weld Plate LBBU-SP (**Type of Mounting SP**)

Dimensions applicable only when used with Hexagon Rail Nut SM 2-5D (**Type of Mounting SM**)

Dimensions applicable only when used for panel mounting without Weld Plate or Hexagon Rail Nut (**Type of Mounting PM**)

Group STAUFF	Dimensions (mm/in)			Order Codes (Standard Options)
	ØD1	ØD2	L	
1	12	9	13,5	LBBU-HUE 1/1D SP
	.47	.35	.53	M8-U5/16 W3
2	12	9	17,5	LBBU-HUE 2/2D SP
	.47	.35	.69	M8-U5/16 W3
3	12	9	33,5	LBBU-HUE 3/3D SP
	.47	.35	1.32	M8-U5/16 W3
1D	12	9	13,5	LBBU-HUE 1/1D SP
	.47	.35	.53	M8-U5/16 W3
2D	12	9	17,5	LBBU-HUE 2/2D SP
	.47	.35	.69	M8-U5/16 W3
3D	12	9	13,5	LBBU-HUE 3/3D SP
	.47	.35	1.32	M8-U5/16 W3

Group STAUFF	Dimensions (mm/in)			Order Codes (Standard Options)
	ØD1	ØD2	L	
1	12	9	12,8	LBBU-HUE 1/1D SM
	.47	.35	.50	M8-U5/16 W3
2	12	9	16,8	LBBU-HUE 2/2D SM
	.47	.35	.66	M8-U5/16 W3
3	12	9	32,8	LBBU-HUE 3/3D SM
	.47	.35	1.29	M8-U5/16 W3
1D	12	9	12,8	LBBU-HUE 1/1D SM
	.47	.35	.50	M8-U5/16 W3
2D	12	9	16,8	LBBU-HUE 2/2D SM
	.47	.35	.66	M8-U5/16 W3
3D	12	9	32,8	LBBU-HUE 3/3D SM
	.47	.35	1.29	M8-U5/16 W3

Group STAUFF	Dimensions (mm/in)			Order Codes (Standard Options)
	ØD1	ØD2	L	
1	12	9	18,8	LBBU-HUE 1/1D PM
	.47	.35	.74	M8-U5/16 W3
2	12	9	22,7	LBBU-HUE 2/2D PM
	.47	.35	.89	M8-U5/16 W3
3	12	9	38,8	LBBU-HUE 3/3D PM
	.47	.35	1.53	M8-U5/16 W3
1D	12	9	18,8	LBBU-HUE 1/1D PM
	.47	.35	.74	M8-U5/16 W3
2D	12	9	22,7	LBBU-HUE 2/2D PM
	.47	.35	.89	M8-U5/16 W3
3D	12	9	38,8	LBBU-HUE 3/3D PM
	.47	.35	1.53	M8-U5/16 W3

Alternative sizes (e.g. for bolts M6 and 1/4-20 UNC), materials and surface finishings are available upon request.

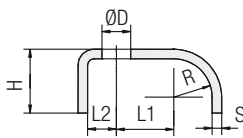
Cover Plate
Type LBBU-DP

STAUFF Group 1 to 3

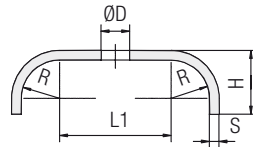

STAUFF Group 1D to 3D



Group STAUFF	Dimensions (mm/in)						Order Codes (Standard Options)
	Ø D	L1	L2	R	H	S	
1	9	15	9	10	16	3	LBBU-DP 1 M8-U5/16 W3
	.35	.59	.35	.39	.63	.12	
2	9	18	9	12	20	3	LBBU-DP 2 M8-U5/16 W3
	.35	.71	.35	.47	.79	.12	
3	9	23,5	15	19,5	28	3	LBBU-DP 3 M8-U5/16 W3
1D	9	30	X	10	16	3	LBBU-DP 1D M8-U5/16 W3
	.35	1.18		.39	.63	.12	
2D	9	35		12	20	3	LBBU-DP 2D M8-U5/16 W3
	.35	1.38		.47	.79	.12	
3D	9	47	19,5	28	3	LBBU-DP 3D M8-U5/16 W3	
	.35	1.85	.77	.63	.12		

Alternative sizes (e.g. for bolts M6 and 1/4–20 UNC), materials and surface finishings are available upon request.

Order Codes

Cover Plate *LBBU-DP*1D*M8-U5/16*W3

* Light Series LBBU	LBBU
* Cover Plate	-DP
* STAUFF Group	1D
* Thread code (suitable for bolts M8 and U5/16)	M8-U5/16
* Material code Carbon Steel, zinc/nickel-plated	W3

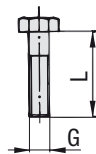

Please also ask for the **Anti-Twist Feature** to prevent turning of the components. Consult STAUFF for further information.

 Hexagon Head Bolt
Type AS

Hexagon Head Bolt AS

(according to DIN 931 / 933 or ANSI / ASME B18.2.1.)

Dimensions applicable only when used with
Weld Plate LBBU-SP (Type of Mounting SP)
or Hexagon Rail Nut SM 2-5D (Type of Mounting SM)

Hexagon Head Bolt AS

(according to DIN 931 / 933 or ANSI / ASME B18.2.1.)

Dimensions applicable only when used for panel mounting
without Weld Plate or Hexagon Rail Nut
(Type of Mounting PM)



Group STAUFF	Dimensions (mm/in)		Order Codes (Standard Options)
	Thread	G x L	
1	M8 x 25		AS M8x25 W3
	5/16–18 UNC x 1		AS U5/16-18x1 W3
2	M8 x 28		AS M8x28 W3
	5/16–18 UNC x 1-1/8		AS U5/16-18x1-1/8 W3
3	M8 x 45		AS M8x45 W3
	5/16–18 UNC x 1-3/4		AS U5/16-18x1-3/4 W3
1D	M8 x 25		AS M8x25 W3
	5/16–18 UNC x 1		AS U5/16-18x1 W3
2D	M8 x 28		AS M8x28 W3
	5/16–18 UNC x 1-1/8		AS U5/16-18x1-1/8 W3
3D	M8 x 45		AS M8x45 W3
	5/16–18 UNC x 1-3/4		AS U5/16-18x1-3/4 W3

Group STAUFF	Dimensions (mm/in)		Order Codes (Standard Options)
	Thread	G x L	
1	M8 x 30		AS M8x30 W3
	5/16–18 UNC x 1-1/4		AS U5/16-18x1-1/4 W3
2	M8 x 35		AS M8x28 W3
	5/16–18 UNC x 1-3/8		AS U5/16-18x1-3/8 W3
3	M8 x 50		AS M8x45 W3
	5/16–18 UNC x 2		AS U5/16-18x2 W3
1D	M8 x 30		AS M8x30 W3
	5/16–18 UNC x 1-1/4		AS U5/16-18x1-1/4 W3
2D	M8 x 35		AS M8x28 W3
	5/16–18 UNC x 1-3/8		AS U5/16-18x1-3/8 W3
3D	M8 x 50		AS M8x45 W3
	5/16–18 UNC x 2		AS U5/16-18x2 W3

Order Codes

Hexagon Head Bolt *AS*M8x25*W3

* Type of bolt	Hexagon Head Bolt (according to DIN 931 / 933 or ANSI / ASME B18.2.1.)	AS
* Thread code	Thread dimension according to dimension table	M8x25
* Material code	Carbon Steel, zinc/nickel-plated	W3

All threaded parts are available with Metric ISO thread or unified coarse (UNC) thread according to dimension table.

Alternative sizes (e.g. for bolts M6 and 1/4–20 UNC), materials and surface finishings are available upon request.

Clamp Body - Single Design

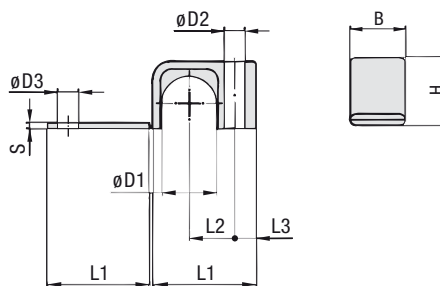
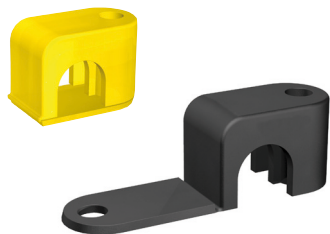

Order Codes

Clamp Body

***LB*1*03,2*PP**

- * Light Series: Clamp Body / Single Design **LB**
- * STAUFF Group **1**
- * Exact outside diameter Ø D1 (mm) **03,2**
- * Material code (see below) **PP**

Standard Materials



Polypropylene
Colour: Black
Material code: **PP**



Polyamide
Colour: Yellow
Material code: **PA**

See page A86 for material properties and technical information.

Alternative materials are available upon request.
Please consult STAUFF for further information.

Applications

- Pneumatics, Instrumentation and Automotive Technology,
Machine Tool Industry, Lubrication, Mechanical Engineering

Group	Outside Diameter		Nominal Bore Pipe	Order Codes (1 Clamp Body)	Dimensions (mm/in)									
	Pipe / Tube / Hose	Ø D1			(mm)	(in)	(** = Material)	L1	L2	L3	B	H	S	Ø D2
1		3,2	1/8		LB 103,2 **									
		6			LB 106 **	22	9	6,5	12	10,5	2	6,8	7	
		6,4	1/4		LB 106,4 **	.87	.35	.26	.47	.41	.08	.27	.28	
		8			LB 108 **									
2		9,5	3/8		LB 209,5 **									
		10		1/8	LB 210 **	27	11	7	16	15	2	6,8	7	
		11,1			LB 211,1 **	1.06	.43	.28	.63	.59	.08	.27	.28	
		12			LB 212 **									
3		12,7	1/2		LB 312,7 **									
		13,5		1/4	LB 313,5 **									
		14			LB 314 **									
		15			LB 315 **	34	15	7	20	22,5	2	6,8	7	
		16	5/8		LB 316 **	1.34	.59	.28	.79	.89	.08	.27	.28	
		17,2		3/8	LB 317,2 **									
4		18			LB 318 **									
		19	3/4		LB 419 **									
		20			LB 420 **									
		21,3		1/2	LB 421,3 **	42	19	7	20	30	2	6,8	7	
		22			LB 422 **	1.65	.75	.28	.79	1.18	.08	.27	.28	
		25			LB 425 **									
	25,4	1		LB 425,4 **										

Additional outside diameters are available upon request. Please consult STAUFF for further information.

Clamp Body - Twin Design

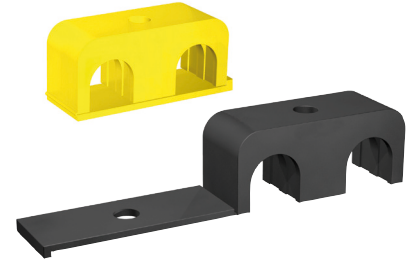
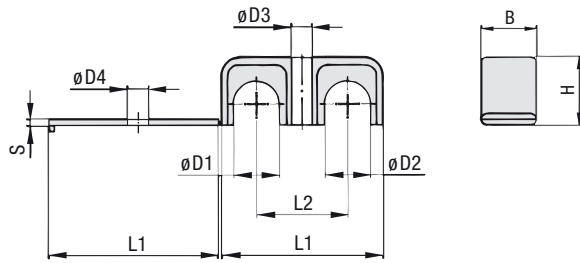

Group	Outside Diameters		Nominal Bore Pipe	Order Codes (1 Clamp Body)	Dimensions (mm/in)						
	Pipe / Tube / Hose Ø D1 / Ø D2				(** = Material)	L1	L2	B	H	S	Ø D3
1	3,2	1/8		LBG 103,2/03,2 **	31	18	12	10,5	2	6,8	7
	6			LBG 106/06 **	1.22	.71	.47	.41	.08	.27	.28
	6,4	1/4		LBG 106,4/06,4 **							
	8			LBG 108/08 **							
2	9,5	3/8		LBG 209,5/09,5 **	39	22	16	15	2	6,8	7
	10		1/8	LBG 210/10 **	1.54	.87	.63	.59	.08	.27	.28
	11,1			LBG 211,1/11,1 **							
	12			LBG 212/12 **							
3	12,7	1/2		LBG 312,7/12,7 **	53	30	20	22,5	2	6,8	7
	13,5		1/4	LBG 313,5/13,5 **	2.09	1.18	.79	.89	.08	.27	.28
	14			LBG 314/14 **							
	15			LBG 315/15 **							
	16	5/8		LBG 316/16 **							
	17,2		3/8	LBG 317,2/17,2 **							
4	18			LBG 318/18 **							
	19	3/4		LBG 419/19 **	70	38	20	30	2	6,8	7
	20			LBG 420/20 **	2.76	1.50	.79	1.18	.08	.27	.28
	21,3		1/2	LBG 421,3/21,3 **							
	22			LBG 422/22 **							
	25			LBG 425/25 **							
	25,4	1		LBG 425,4/25,4 **							

Order Codes

Clamp Body *LBG*1*03,2/03,2*PP

- * Light Series: Clamp Body / Twin Design with identical diameters **LBG**
- Clamp Body / Twin Design with different diameters **LBU**
- * STAUFF Group **1**
- * Exact outside diameters Ø D1 / Ø D2 (mm) **03,2/03,2**
- * Material code (see below) **PP**

Standard Materials

Polypropylene
 Colour: Black
 Material code: **PP**

Polyamide
 Colour: Yellow
 Material code: **PA**

See page A86 for material properties and technical information.

 Alternative materials are available upon request.
 Please consult STAUFF for further information.

Applications

- Pneumatics, Instrumentation and Automotive Technology, Machine Tool Industry, Lubrication, Mechanical Engineering

Additional outside diameters and combinations of different outside diameters (Clamp Body, Type LBU) are available upon request.
 Please consult STAUFF for further information.

Clamp Body - Single Design

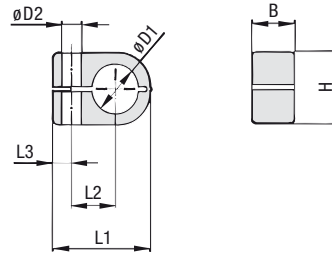
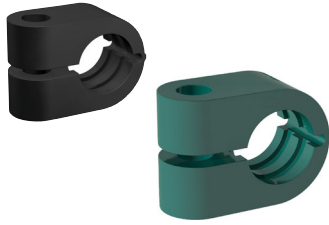

Order Codes

Clamp Body

*LN*1*06*PP

- * Light Series: Clamp Body / Single Design **LN**
- * STAUFF Group **1**
- * Exact outside diameter Ø D1 (mm) **06**
- * Material code (see below) **PP**

Standard Materials



Polypropylene
Colour: Green
Material code: **PP**



Polyamide
Colour: Black
Material code: **PA**

See page A86 for material properties and technical information.

Alternative materials are available upon request. Please consult STAUFF for further information.

Applications

- Pneumatics, Instrumentation and Automotive Technology, Machine Tool Industry, Lubrication, Mechanical Engineering

Group	Outside Diameter Pipe / Tube / Hose Ø D1		Nominal Bore Pipe (in)	Order Codes (1 Clamp Body) (* = Material)	Dimensions (mm/in)					
	(mm)	(in)			L1	L2	L3	B	H	Ø D2
1	6			LN 106 **	22	9	7	14,5	13,5	6,8
	6,4	1/4		LN 106,4 **	.87	.35	.28	.57	.53	.27
	8			LN 108 **						
2	8			LN 208 **						
	9,5	3/8		LN 209,5 **	27	11	7	14,5	18,5	6,8
	10		1/8	LN 210 **	1.06	.43	.28	.57	.59	.27
	12			LN 212 **						
3	12,7	1/2		LN 212,7 **						
	10		1/8	LN 310 **						
	12			LN 312 **						
	12,7	1/2		LN 312,7 **						
	13,5		1/4	LN 313,5 **	33	15	7	14,5	23,5	6,8
	14			LN 314 **	1.30	.59	.28	.57	.93	.27
4	15			LN 315 **						
	16	5/8		LN 316 **						
	14			LN 414 **						
	15			LN 415 **						
	16	5/8		LN 416 **						
	17,2		3/8	LN 417,2 **	40	19	7	14,5	30,5	6,8
	18			LN 418 **	1.57	.75	.28	.57	1.20	.27
	19	3/4		LN 419 **						
20			LN 420 **							
21,3		1/2	LN 421,3 **							
22			LN 422 **							

Additional outside diameters are available upon request. Please consult STAUFF for further information.

Clamp Body ▪ Twin Design

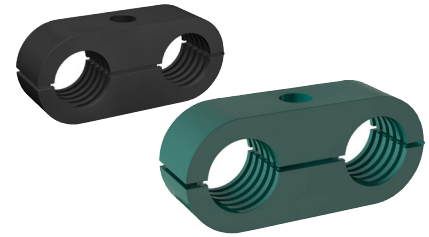
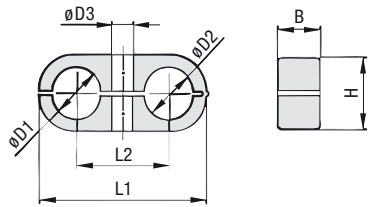

Group STAUFF	Outside Diameters Pipe / Tube / Hose Ø D1 / Ø D2		Nominal Bore Pipe (in)	Order Codes (1 Clamp Body) (** = Material)	Dimensions (mm/in)				
	(mm)	(in)			L1	L2	B	H	Ø D2
1	6			LNGF 106/06 **	32	18	14,5	13,5	6,8
	6,4	1/4		LNGF 106,4/06,4 **	1.26	.70	.57	.53	.27
	8			LNGF 108/08 **					
2	8			LNGF 208/08 **					
	9,5	3/8		LNGF 209,5/09,5 **	41	22	14,5	18,5	6,8
	10		1/8	LNGF 210/10 **	1.61	.86	.57	.59	.27
	12			LNGF 212/12 **					
3	12,7	1/2		LNGF 212,7/12,7 **					
	10		1/8	LNGF 310/10 **					
	12			LNGF 312/12 **					
	12,7	1/2		LNGF 312,7/12,7 **	54	30	14,5	23,5	6,8
	13,5		1/4	LNGF 313,5/13,5 **	2.13	1.18	.57	.93	.27
	14			LNGF 314/14 **					
4	15			LNGF 315/15 **					
	16	5/8		LNGF 316/16 **					
	14			LNGF 414/14 **					
	15			LNGF 415/15 **					
	16	5/8		LNGF 416/16 **					
	17,2		3/8	LNGF 417,2/17,2 **	70	37	14,5	30,5	6,8
	18			LNGF 418/18 **	2.76	1.50	.57	1.20	.27
	19	3/4		LNGF 419/19 **					
20			LNGF 420/20 **						
21,3		1/2	LNGF 421,3/21,3 **						
22			LNGF 422/22 **						

Order Codes

Clamp Body

***LNGF*1*06/06*PP**

- * Light Series: Clamp Body / Twin Design with identical diameters **LNGF**
- Clamp Body / Twin Design with different diameters **LNUF**
- * STAUFF Group **1**
- * Exact outside diameters Ø D1 / Ø D2 (mm) **06/06**
- * Material code (see below) **PP**

Standard Materials

Polypropylene
Colour: Green
Material code: **PP**

Polyamide
Colour: Black
Material code: **PA**

See page A86 for material properties and technical information. Alternative materials are available upon request. Please consult STAUFF for further information.

Applications

- Pneumatics, Instrumentation and Automotive Technology, Machine Tool Industry, Lubrication, Mechanical Engineering

Additional outside diameters and combinations of different outside diameters (Clamp Body, type LNUF) are available upon request. Please consult STAUFF for further information.

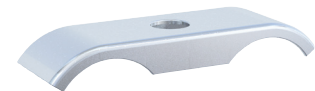
 Cover Plate
Type DPL

Group STAUFF	Dimensions (mm/in)			Order Codes (Standard Options)
	L4	B2	Ø D4	
1	29,5	15,5	6,8	DPL 1 W3
	1.16	.61	.27	
2	40	15,5	6,8	DPL 2 W3
	1.57	.61	.27	
3	51	16	6,8	DPL 3 W3
	2.01	.63	.27	
4	63,5	16	6,8	DPL 4 W3
	2.50	.63	.27	

Order Codes

Cover Plate

***DPL*1*W3**

- * Cover Plate for Clamp Body / Twin Design **DPL**
- * STAUFF Group **1**
- * Material code Carbon Steel, zinc/nickel-plated **W3**

Alternative materials and surface finishings are available upon request. Consult STAUFF for further information. Please note: The maximum tightening torque for bolts is 2,5 N·m (1.85 ft·lb).

Construction Series
Types KS (Single Version) / DKS (Double Version)

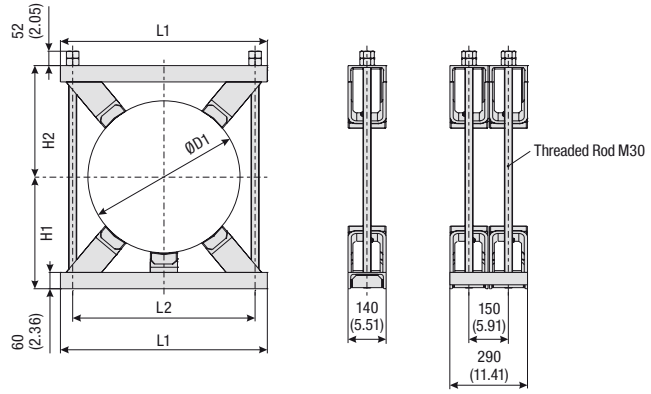
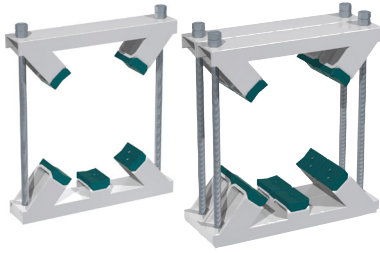

Order Codes

Construction Series *KS*220*W7*PP

* Version Single version **KS**
 Double version **DKS**

* Exact outside diameter ØD1 (mm) **220**

* Material Code Steel, prime coated **W7**
 Steel, hot-dip galvanised **W40**

* Material of Plastic Pads (see below) **PP**

Please note: All items are supplied non-assembled.

Standard Materials for Plastic Pads

Polypropylene
Colour: Green
Material Code: **PP**

Polyamide
Colour: Black
Material Code: **PA**

See page A86 for material properties and technical information.

Group	Outside Diameter ØD1 Pipe / Tube		Standard Diameters		Dimensions (mm/in)				No. of Plastic Pads
	STAUFF	(mm)	(in)	(mm)	(in)	L1	L2	H1	
1	220 ... 275	8.66 ... 10.85	220	8.66	420	330	220	220	4
			247	9.72					
			267	10.51					
			273	10.75					
2	276 ... 325	10.87 ... 12.80	280	11.02	460	370	240	240	4
			300	11.81					
			318	12.52					
			323,9	12.75					
3	326 ... 370	12.83 ... 14.57	355,6	14.00	510	420	260	260	4
			368	14.49					
4	371 ... 425	14.61 ... 16.73	390	15.35	570	480	290	290	4
			406,4	16.00					
5	426 ... 485	16.77 ... 19.09	457,2	18.00	620	530	305	305	4
			470	18.50					
6	486 ... 550	19.13 ... 21.65	490	19.29	680	590	370	370	4
			508	20.00					
			521	20.51					
			546	21.50					
7	551 ... 630	21.69 ... 24.80	558,8	22.00	760	670	410	410	5
			609,6	24.00					
8	631 ... 715	24.84 ... 28.15	711	28.00	845	755	452	452	5
					33.27	29.72	17.80	17.80	
9	716 ... 800	28.19 ... 31.50	762	30.00	940	850	495	495	5
					37.00	33.46	19.49	19.49	
10			813	32.00	990	900	500	500	5
					38.97	35.43	19.69	19.69	
11			1000	39.37	1200	1100	591,5	593	5
					47.24	43.30	23.29	23.34	
12			1016	40.00	1200	1100	602	602	5
					47.24	43.30	23.70	23.70	

Alternative outside diameters, materials and surface finishings are available upon request. Consult STAUFF for further information.

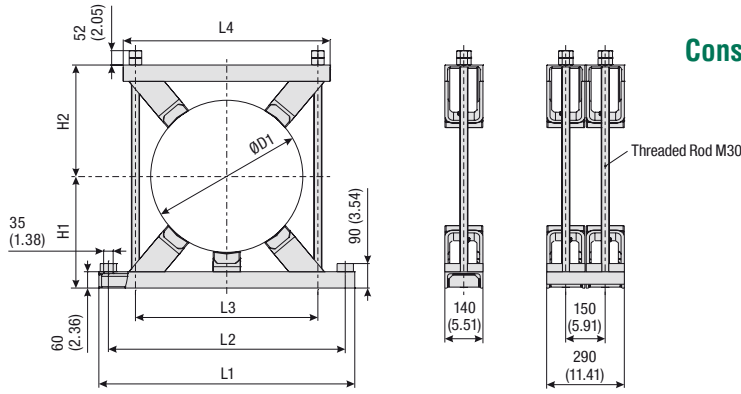
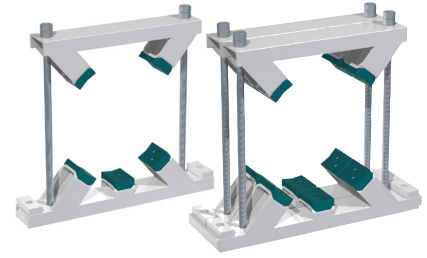
Construction Series for Anchor Bolt Fastening Types KSV (Single) / DKSV (Double)

Group STAUFF	Outside Diameter ØD1 Pipe / Tube Diameter Range		Standard Diameters		Dimensions (mm/in)						No. of Plastic Pads
	(mm)	(in)	(mm)	(in)	L1	L2	L3	L4	H1	H2	
1	220 ... 275	8.66 ... 10.85	220	8.66	580	330	490	420	220	220	4
			247	9.72							
			267	10.51							
			273	10.75							
2	276 ... 325	10.87 ... 12.80	280	11.02	620	370	530	460	240	240	4
			300	11.81							
			318	12.52							
			323,9	12.75							
3	326 ... 370	12.83 ... 14.57	355,6	14.00	670	420	580	510	260	260	4
			368	14.49							
4	371 ... 425	14.61 ... 16.73	390	15.35	750	480	640	570	290	290	4
			406,4	16.00							
5	426 ... 485	16.77 ... 19.09	457,2	18.00	800	530	730	620	305	305	4
			470	18.50							
6	486 ... 550	19.13 ... 21.65	490	19.29	860	590	790	680	370	370	4
			508	20.00							
			521	20.51							
			546	21.50							
7	551 ... 630	21.69 ... 24.80	558,8	22.00	940	670	870	760	410	410	5
			609,6	24.00							
8	631 ... 715	24.84 ... 28.15	711	28.00	1025	755	955	845	452	452	5
					40.31	29.72	37.60	33.27	17.80	17.80	
9	716 ... 800	28.19 ... 31.50	762	30.00	1120	850	1050	940	495	495	5
					44.09	33.46	41.33	37.00	19.49	19.49	
10			813	32.00	1170	900	1100	990	500	500	5
					46.06	35.43	43.30	38.97	19.69	19.69	
11			1000	39.37	1400	1100	1300	1200	591,5	593	5
					55.12	43.30	51.18	47.24	23.29	23.34	
12			1016	40.00	1400	1100	1300	1200	602	602	5
					55.12	43.30	51.18	47.24	23.70	23.70	

Order Codes
Construction Series *KSV*220*W7*PP

* Version	Single version	KSV
	Double version	DKSV
* Exact outside diameter ØD1 (mm)		220
* Material Code	Steel, prime coated	W7
	Steel, hot-dip galvanised	W40
* Material of Plastic Pads (see below)		PP

Please note: All items are supplied non-assembled.

Standard Materials for Plastic Pads
Polypropylene
 Colour: Green
 Material Code: **PP**
Polyamide
 Colour: Black
 Material Code: **PA**

See page A86 for material properties and technical information.

Alternative outside diameters, materials and surface finishings are available upon request. Consult STAUFF for further information.

Flat Steel U-Bolt with Plastic Pipe Saddle (Short) and U-Profile
Type FB+RUK (To be used as Fixed Point Clamps only)

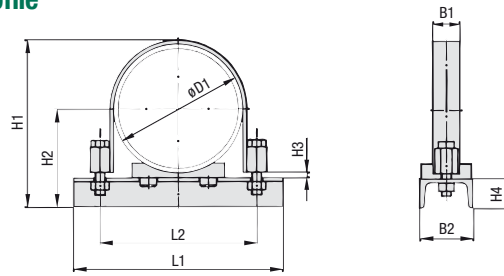
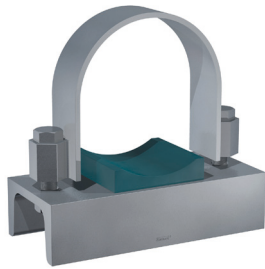

Flat Steel U-Bolt (type FB) with Plastic Pipe Saddle (type RUK), U-Profile and Hexagon Head Bolts

Order Codes

Clamp Assembly *FB+RUK*PP*48,3*W1

One clamp assembly is consisting of one Flat Steel U-Bolt (type FB), one Plastic Pipe Saddle (type RUK), one U-Profile (to DIN 1026) with two Nuts (to DIN EN ISO 4032) and two Hexagon Head Bolts (to DIN EN ISO 4014 / 4017).

- * Clamp Assembly (as listed above) **FB+RUK**
- * Material of Pipe Saddle (see below) **PP**
- * Exact outside diameter Ø D1 (mm) **48,3**
- * Material code Carbon Steel, untreated **W1**
 Carbon Steel, zinc-plated (Fe/Zn 8 C) **W3**
 Stainless Steel V4A **W5**
 1.4401 / 1.4571 (AISI 316 / 316 Ti) **W5**
 Carbon Steel, Plastic coated **W6**

Please note: All items are supplied non-assembled.

Standard Materials for Plastic Pipe Saddles

Polypropylene
 Colour: Green
 Material code: **PP**

Polyamide
 Colour: Black
 Material code: **PA**

See page A86 for material properties and technical information.

Alternative materials are available upon request.
 Please consult STAUFF for further information.

Diameter Nominal DN	Outside Diameter Pipe / Tube Ø D1		Nominal Bore Pipe (in)	Dimensions (mm/in)						U-Profile (DIN 1026) B2 x H4
	(mm)	(in)		Flat Steel U-Bolt (Type FB)						
40	48,3	1.93	1-1/2	100	76	95	67	5	20 x 3	50 x 38
				3.94	2.99	3.74	2.64	.20	.78 x .12	1.97 x 1.50
50	57	2.28	2	115	85	103	71,5	5	20 x 3	50 x 38
				4.53	3.35	4.06	2.81	.20	.78 x .12	1.97 x 1.50
65	60,3	2.41	2	115	88	106	73,2	5	20 x 3	50 x 38
				4.53	3.46	4.17	2.88	.20	.78 x .12	1.97 x 1.50
80	76,1	3.04	2-1/2	132	104	122	81	5	20 x 3	50 x 38
				5.20	4.09	4.80	3.19	.20	.78 x .12	1.97 x 1.50
100	88,9	3.56	3	160	122	146	97,5	8	40 x 4	80 x 45
				6.30	4.80	5.75	3.84	.31	1.57 x .16	3.15 x 1.77
125	108	4.32	4	170	140	165	107	8	40 x 4	80 x 45
				6.69	5.51	6.50	4.21	.31	1.57 x .16	3.15 x 1.77
150	114,3	4.57	4	180	147	171	110	8	40 x 4	80 x 45
				7.09	5.79	6.73	4.33	.31	1.57 x .16	3.15 x 1.77
175	133	5.32	5	210	165	190	119,5	8	40 x 4	80 x 45
				8.27	6.50	7.48	4.70	.31	1.57 x .16	3.15 x 1.77
200	139,7	5.59	5	210	172	197	123	8	40 x 4	80 x 45
				8.27	6.77	7.76	4.84	.31	1.57 x .16	3.15 x 1.77
250	159	6.36	6	265	201	220	132,5	8	40 x 6	80 x 45
				1.43	7.91	8.66	5.22	.31	1.57 x .24	3.15 x 1.77
300	168,3	6.73	6	275	211	230	137	8	40 x 6	80 x 45
				1.83	8.31	9.06	5.39	.31	1.57 x .24	3.15 x 1.77
350	193,7	7.75	8	305	236	255	150	8	40 x 6	80 x 45
				12.01	9.29	1.04	5.91	.31	1.57 x .24	3.15 x 1.77
400	216	8.64	8	320	260	277	161	8	40 x 6	80 x 45
				12.60	1.24	1.91	6.34	.31	1.57 x .24	3.15 x 1.77
450	219,1	8.76	8	320	261	280	162,5	8	40 x 6	80 x 45
				12.60	1.28	11.02	6.40	.31	1.57 x .24	3.15 x 1.77
500	267	10.68	10	380	325	328	186,5	8	40 x 8	80 x 45
				14.96	12.80	12.91	7.34	.31	1.57 x .31	3.15 x 1.77
550	273	10.92	10	385	330	334	189,5	8	40 x 8	80 x 45
				15.16	12.99	13.15	7.46	.31	1.57 x .31	3.15 x 1.77
600	318	12.72	12	440	375	382	212	8	40 x 8	80 x 45
				17.32	14.76	15.04	8.35	.31	1.57 x .31	3.15 x 1.77
650	323,9	12.96	12	450	382	390	215	8	40 x 8	80 x 45
				17.72	15.04	15.35	8.46	.31	1.57 x .31	3.15 x 1.77
700	355,6	14.22	14	480	420	421	235	12	60 x 8	100 x 50
				18.90	16.54	16.57	9.25	.47	2.36 x .31	3.94 x 1.97
750	368	14.72	14	490	430	434	242	12	60 x 8	100 x 50
				19.29	16.93	17.09	9.53	.47	2.36 x .31	3.94 x 1.97
800	406,4	16.26	16	550	470	472	261	12	60 x 8	100 x 50
				21.65	18.50	18.58	1.28	.47	2.36 x .31	3.94 x 1.97
850	419	16.76	16	550	482	485	267,5	12	60 x 8	100 x 50
				21.65	18.98	19.09	1.53	.47	2.36 x .31	3.94 x 1.97
900	457	18.28	18	585	520	523	286,5	12	60 x 8	100 x 50
				23.03	2.47	2.59	11.28	.47	2.36 x .31	3.94 x 1.97
950	508	20.32	20	630	570	574	312	12	60 x 8	100 x 50
				24.80	22.44	22.60	12.28	.47	2.36 x .31	3.94 x 1.97
1000	521	20.84	20	640	585	587	319	12	60 x 8	100 x 50
				25.20	23.03	23.11	12.56	.47	2.36 x .31	3.94 x 1.97

Alternative materials and surface finishings are available upon request. Consult STAUFF for further information.

Flat Steel U-Bolt with Plastic Pipe Saddle (Short) and U-Profile (To be used as Fixed Point Clamps only) Type FB+RUK

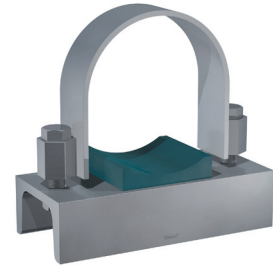
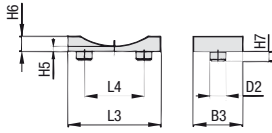
Plastic Pipe Saddle (type RUK)

(For size DN 40, dimension L4 is staggered by 90°)

Hexagon Head Bolt AS

(according to DIN EN ISO 4014 / 4017)

Diameter Nominal DN	Outside Diameter Pipe / Tube Ø D1		Nominal Bore Pipe (in)	Dimensions (mm/in)							Hexagon Head Bolt (DIN EN ISO 4014 / 4017) Thread G x L
	(mm)	(in)		Plastic Pipe Saddle (type RUK)							
				L3	L4	B3	D2	H5	H6	H7	
40	48,3	1.93	1-1/2	24	25	35	8	5	8	5	M10 x 40
				.94	.98	1.38	.31	.20	.31	.20	
50	57	2.28		38	25	50	10	5	10	6	M10 x 40
	60,3	2.41	2	1.50	.98	1.97	.39	.20	.39	.24	
65	76,1	3.04	2-1/2	38	25	50	10	5	10	6	M10 x 40
				1.50	.98	1.97	.39	.20	.39	.24	
80	88,9	3.56	3	75	40	70	15	8	17	10	M 12 x 55
				2.95	1.57	2.76	.59	.31	.67	.39	
100	108	4.32		75	40	70	15	8	17	10	M 12 x 55
	114,3	4.57	4	2.95	1.57	2.76	.59	.31	.67	.39	
125	133	5.32		75	40	70	15	8	17	10	M 12 x 55
				2.95	1.57	2.76	.59	.31	.67	.39	
150	159	6.36		75	40	70	15	8	17	10	M 12 x 55
				2.95	1.57	2.76	.59	.31	.67	.39	
175	193,7	7.75		140	90	75	25	8	26	10	M 16 x 75
				5.51	3.54	2.95	.98	.31	1.02	.39	
200	216	8.64		140	90	75	25	8	26	10	M 16 x 75
				5.51	3.54	2.95	.98	.31	1.02	.39	
250	267	10.68		140	90	75	25	8	26	10	M 16 x 75
				5.51	3.54	2.95	.98	.31	1.02	.39	
300	318	12.72		140	90	75	25	8	26	10	M 20 x 80
				5.51	3.54	2.95	.98	.31	1.02	.39	
350	355,6	14.22	14	220	150	75	30	8	32	10	M 20 x 80
				8.66	5.91	2.95	1.18	.31	1.26	.39	
400	406,4	16.26	16	220	150	75	30	8	32	10	M 24 x 100
				8.66	5.91	2.95	1.18	.31	1.26	.39	
500	508	20.32	20	220	150	75	30	8	32	10	M 24 x 100
				8.66	5.91	2.95	1.18	.31	1.26	.39	
	521	20.84		220	150	75	30	8	32	10	M 24 x 100
				8.66	5.91	2.95	1.18	.31	1.26	.39	

Order Codes

only Flat Steel U-Bolt

***FB*A 48,3*W1**

- * Flat Steel U-Bolt **FB**
- * Exact outside diameter Ø D1 (mm) **A 48,3**
- * Material code Carbon Steel, untreated **W1**
- Carbon Steel, zinc-plated (Fe/Zn 8 C) **W3**
- Stainless Steel V4A 1.4401 / 1.4571 (AISI 316 / 316 Ti) **W5**
- Carbon Steel, Plastic coated **W6**

only Plastic Pipe Saddle

***RUK*48,3*PP**

- * Plastic Pipe Saddle (Short) **RUK**
- * Exact outside diameter Ø D1 (mm) **48,3**
- * Material of Pipe Saddle (see below) **PP**

Please note: All items are supplied non-assembled.

Standard Materials for Plastic Pipe Saddles

Polypropylene
 Colour: Green
 Material code: **PP**

Polyamide
 Colour: Black
 Material code: **PA**

See page A86 for material properties and technical information.

 Alternative materials are available upon request.
 Please consult STAUFF for further information.

Alternative materials and surface finishings are available upon request. Consult STAUFF for further information.

**Round Steel U-Bolt with Plastic Pipe Saddle (Short)
Type RB+RUK**

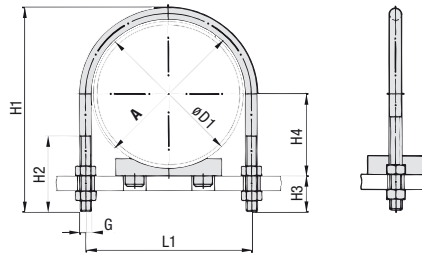

Round Steel U-Bolt (type RB) with Plastic Pipe Saddle (type RUK)

Order Codes

Clamp Assembly *RB*W1*RUK*PP*48,3

One clamp assembly is consisting of one Round Steel U-Bolt (type RB), one Plastic Pipe Saddle (type RUK) and four Nuts (to DIN EN ISO 4032).

- * Round Steel U-Bolt **RB**
- * Material code Carbon Steel, untreated **W1**
- Stainless Steel V4A **W5**
- 1.4401 / 1.4571 (AISI 316 / 316 Ti)
- Carbon Steel, Plastic coated **W6**
- Carbon Steel, zinc-plated and thick-film passivated **W66**
- * Plastic Pipe Saddle (Short) **RUK/**
- * Material of Pipe Saddle (see below) **PP**
- * Exact outside diameter Ø D1 (mm) **48,3**

Please note: All items are supplied non-assembled.

Standard Materials for Plastic Pipe Saddles



Polypropylene
Colour: Green
Material code: **PP**



Polyamide
Colour: Black
Material code: **PA**

See page A86 for material properties and technical information.

Alternative materials are available upon request.
Please consult STAUFF for further information.

Diameter Nominal DN	Outside Diameter Pipe / Tube Ø D1		Nominal Bore Pipe (in)	Dimensions (mm/in)						
	(mm)	(in)		Round Steel U-Bolt (Type RB)						Thread G
20	25	.98	3/4	30	40	73,5	41	30	17,5	
	26,9	1.06			1.57	2.89	1.61	1.18	.69	
25	30	1.18	1	38	48	81	48	30	20	M10
	33,7	1.33			1.89	3.19	1.89	1.18	.79	
32	38	1.50	1-1/4	46	56	89	48	30	24	M10
	42,4	1.69			2.20	3.50	1.89	1.18	.94	
40	44,5	1.76	1-1/2	52	62	100	55	35	27,2	M10
	48,3	1.90			2.44	3.94	2.17	1.38	1.07	
50	57	2.28	2	64	76	118	63	39	33,5	M12
	60,3	2.41			2.99	4.65	2.48	1.54	1.32	
65	76,1	3.04	2-1/2	82	94	135	77	39	43	M12
	80	3.56			3.23	3.70	5.31	3.03	1.54	
100	108	4.32	4	120	136	190	105	49	62	M12
	114,3	4.57			4.72	5.35	7.48	4.13	1.93	
125	133	5.32	5	148	164	217	105	49	74,5	M16
	139,7	5.59			5.83	6.46	8.54	4.13	1.93	
150	159	6.36	6	176	192	247	105	51	87,5	M16
	168,3	6.73			6.93	7.56	9.72	4.13	2.01	
175	193,7	7.75	8	202	218	273	105	51	105	M16
	200	8.64			7.96	8.58	10.75	4.13	2.01	
200	216	8.64	8	228	248	311	125	59	116	M20
	219,1	8.76			8.98	9.76	12.24	4.92	2.32	
250	267	10.68	10	282	302	364	125	59	141,5	M20
	273	10.92			11.10	11.89	14.33	4.92	2.32	
300	318	12.72	12	332	352	418	125	62	167	M20
	323,9	12.96			13.07	13.86	16.46	4.92	2.44	
350	355,6	14.22	14	378	402	475	145	70	186	M24
	368	14.72			14.88	15.83	18.70	5.71	2.76	
400	406,4	16.26	16	428	452	526	145	70	211	M24
	419	16.76			16.85	17.80	20.71	5.71	2.76	
500	508	20.32	20	530	554	627	145	70	262	M24
	521	20.84			20.87	21.81	24.69	5.71	2.76	

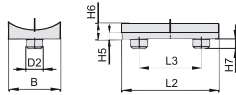
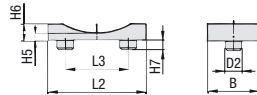
Round Steel U-Bolt with Plastic Pipe Saddle (Short)
 Type RB+RUK

 Plastic Pipe Saddle (type RUK)
 (For sizes DN 20 to DN 40)

 Plastic Pipe Saddle (type RUK)
 (From size DN 50 on)

Diameter Nominal DN	Outside Diameter Pipe / Tube Ø D1 (mm) (in)		Nominal Bore Pipe (in)	Dimensions (mm/in) Plastic Pipe Saddle (Type RUK)							
	A	L2		L3	B	H5	H6	H7	D2		
20	25	.98		30	35	25	24	5	8	5	8
	26,9	1.06	3/4	1.18	1.38	.98	.94	.20	.31	.20	.31
25	30	1.18		38	35	25	24	5	8	5	8
	33,7	1.33	1	1.50	1.38	.98	.94	.20	.31	.20	.31
32	38	1.50		46	35	25	24	5	8	5	8
	42,4	1.69	1-1/4	1.81	1.38	.98	.94	.20	.31	.20	.31
40	44,5	1.76		52	35	25	24	5	8	5	8
	48,3	1.90	1-1/2	2.05	1.38	.98	.94	.20	.31	.20	.31
50	57	2.28		64	38	25	50	5	10	6	10
	60,3	2.41	2	2.52	1.50	.98	1.97	.20	.39	.24	.39
65	76,1	3.04	2-1/2	82	38	25	50	5	10	6	10
				3.23	1.50	.98	1.97	.20	.39	.24	.39
80	88,9	3.56	3	94	75	40	70	8	17	10	15
				3.70	2.95	1.57	2.76	.31	.67	.39	.59
100	108	4.32		120	75	40	70	8	17	10	15
	114,3	4.57	4	4.72	2.95	1.57	2.76	.31	.67	.39	.59
125	133	5.32		148	75	40	70	8	17	10	15
	139,7	5.59	5	5.83	2.95	1.57	2.76	.31	.67	.39	.59
150	159	6.36		176	140	90	75	8	26	10	25
	168,3	6.73	6	6.93	5.51	3.54	2.95	.31	1.02	.39	.98
175	193,7	7.75		202	140	90	75	8	26	10	25
				7.96	5.51	3.54	2.95	.31	1.02	.39	.98
200	216	8.64		228	140	90	75	8	26	10	25
	219,1	8.76	8	8.98	5.51	3.54	2.95	.31	1.02	.39	.98
250	267	1.68		282	140	90	75	8	26	10	25
	273	1.92	10	11.10	5.51	3.54	2.95	.31	1.02	.39	.98
300	318	12.72		332	220	150	75	8	32	10	30
	323,9	12.96	12	13.07	8.66	5.91	2.95	.31	1.26	.39	1.18
350	355,6	14.22	14	378	220	150	75	8	32	10	30
	368	14.72		14.88	8.66	5.91	2.95	.31	1.26	.39	1.18
400	406,4	16.26	16	428	220	150	75	8	32	10	30
	419	16.76		16.85	8.66	5.91	2.95	.31	1.26	.39	1.18
500	508	2.32	20	530	220	150	75	8	32	10	30
	521	2.84		2.87	8.66	5.91	2.95	.31	1.26	.39	1.18

Order Codes

only Round Steel U-Bolt *RB*A 52*W1

One Round Steel U-Bolt (type RB) includes four Nuts (to DIN EN ISO 4032).

* Round Steel U-Bolt	RB
* Dimension A (mm)	A 52
* Material code	Carbon Steel, untreated W1
	Stainless Steel V4A W5
	1.4401 / 1.4571 (AISI 316 / 316 Ti)
	Carbon Steel, Plastic coated W6
	Carbon Steel, zinc-plated and thick-film passivated W66

only Plastic Pipe Saddle *RUK*48,3*PP

* Plastic Pipe Saddle (Short)	RUK
* Exact outside diameter Ø D1 (mm)	48,3
* Material of Pipe Saddle (see below)	PP

Standard Materials for Plastic Pipe Saddles

	Polypropylene Colour: Green Material code: PP
	Polyamide Colour: Black Material code: PA

See page A86 for material properties and technical information.

 Alternative materials are available upon request.
 Please consult STAUFF for further information.

**Round Steel U-Bolt with Plastic Pipe Saddle (Long)
Type RB+RUL**

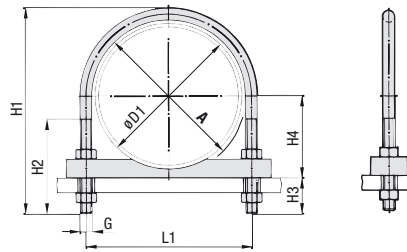

Round Steel U-Bolt (type RB) with Plastic Pipe Saddle (type RUL)

Order Codes

Clamp Assembly *RB*W1*RUL/*PP*48,3

One clamp assembly is consisting of one Round Steel U-Bolt (type RB), one Plastic Pipe Saddle (type RUL) and four Nuts (to DIN EN ISO 4032).

- * Round Steel U-Bolt **RB**
- * Material code Carbon Steel, untreated **W1**
- Stainless Steel V4A 1.4401 / 1.4571 (AISI 316 / 316 Ti) **W5**
- Carbon Steel, Plastic coated **W6**
- Carbon Steel, zinc-plated and thick-film passivated **W66**
- * Plastic Pipe Saddle (Long) **RUL/**
- * Material of Pipe Saddle (see below) **PP**
- * Exact outside diameter Ø D1 (mm) **48,3**

Please note: All items are supplied non-assembled.

Standard Materials for Plastic Pipe Saddles

Polypropylene
Colour: Green
Material code: **PP**

Polyamide
Colour: Black
Material code: **PA**

See page A86 for material properties and technical information.

Alternative materials are available upon request.
Please consult STAUFF for further information.

Diameter Nominal DN	Outside Diameter Pipe / Tube Ø D1 (mm) (in)		Nominal Bore Pipe (in)	Dimensions (mm / in)						
	Round Steel U-Bolt (Type RB)			A	L1	H1	H2	H3	H4	Thread G
20	25	.98		30	40	73.5	41	30	17.5	M10
	26,9	1.06	3/4	1.18	1.57	2.89	1.61	1.18	.69	
25	30	1.18		38	48	81	48	30	20	M10
	33,7	1.33	1	1.50	1.89	3.19	1.89	1.18	.79	
32	38	1.50		46	56	89	48	30	24	M10
	42,4	1.69	1-1/4	1.81	2.20	3.50	1.89	1.18	.94	
40	44,5	1.76		52	62	100	55	35	27.2	M10
	48,3	1.90	1-1/2	2.05	2.44	3.94	2.17	1.38	1.07	
50	57	2.28		64	76	118	63	39	33.5	M12
	60,3	2.41	2	2.52	2.99	4.65	2.48	1.54	1.32	
65	76,1	3.04	2-1/2	82	94	135	77	39	43	M12
				3.23	3.70	5.31	3.03	1.54	1.69	
80	88,9	3.56	3	94	106	152	82	39	45.5	M12
				3.70	4.17	5.98	3.23	1.54	1.79	
100	108	4.32		120	136	190	105	47	64	M12
	114,3	4.57	4	4.72	5.35	7.48	4.13	1.85	2.52	
125	133	5.32		148	164	217	105	47	76.5	M16
	139,7	5.59	5	5.83	6.46	8.54	4.13	1.85	3.01	
150	159	6.36		176	192	247	105	47	91.5	M16
	168,3	6.73	6	6.93	7.56	9.72	4.13	1.85	3.60	
175	193,7	7.75		202	218	273	105	47	109	M16
				7.96	8.58	10.75	4.13	1.85	4.29	
200	216	8.64		228	248	311	125	55	120	M20
	219,1	8.76	8	8.98	9.76	12.24	4.92	2.17	4.72	
250	267	10.68		282	303	364	125	55	145.5	M20
	273	10.92	10	11.10	11.93	14.33	4.92	2.17	5.73	
300	318	12.72		332	352	418	125	55	175	M20
	323,9	12.96	12	13.07	13.86	16.46	4.92	2.17	6.89	
350	355,6	14.22	14	378	402	475	145	63	193	M24
	368	14.72		14.88	15.83	18.70	5.71	2.48	7.60	
400	406,4	16.26	16	428	452	526	145	63	218	M24
	419	16.76		16.85	17.80	20.71	5.71	2.48	8.58	
500	508	20.32	20	530	554	627	145	63	269	M24
	521	20.84		20.87	21.81	24.69	5.71	2.48	10.59	

Round Steel U-Bolt with Plastic Pipe Saddle (Long) Type RB+RUL

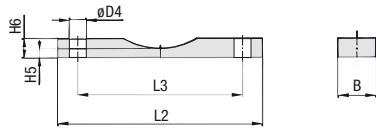

Plastic Pipe Saddle (type RUL)

Diameter Nominal DN	Outside Diameter Pipe / Tube Ø D1 (mm) (in)		Nominal Bore Pipe (in)	Dimensions (mm/in)						
	Plastic Pipe Saddle (Type RUK)			A	L2	L3	B	H5	H6	Ø D4
20	25	.98	3/4	30	75	40	30	5	12	11
	26,9	1.06		1.18	2.95	1.57	1.18	.20	.47	.43
25	30	1.18	1	38	80	48	30	5	12	11
	33,7	1.33		1.50	3.15	1.89	1.18	.20	.47	.43
32	38	1.50	1-1/4	46	90	56	30	5	12	11
	42,4	1.69		1.81	3.54	2.20	1.18	.20	.47	.43
40	44,5	1.76	1-1/2	52	95	62	35	5	15	11
	48,3	1.90		2.05	3.74	2.44	1.38	.20	.59	.43
50	57	2.28	2	64	110	76	35	5	15	14
	60,3	2.41		2.52	4.33	2.99	1.38	.20	.59	.55
65	76,1	3.04	2-1/2	82	135	94	35	5	15	14
80	88,9	3.56	3	94	145	106	40	10	20	14
				3.70	5.71	4.17	1.57	.39	.79	.55
100	108	4.32	4	120	190	136	40	10	20	18
	114,3	4.57		4.72	7.48	5.35	1.57	.39	.79	.71
125	133	5.32	5	148	220	164	40	10	20	18
	139,7	5.59		5.83	8.66	6.46	1.57	.39	.79	.71
150	159	6.36	6	176	250	192	50	12	25	18
	168,3	6.73		6.93	9.84	7.56	1.97	.47	.98	.71
175	193,7	7.75		202	270	218	50	12	25	18
				7.96	10.63	8.58	1.97	.47	.98	.71
200	216	8.64	8	228	315	248	50	12	25	22
	219,1	8.76		8.98	12.40	9.76	1.97	.47	.98	.87
250	267	10.68	10	282	370	302	50	12	25	22
	273	10.92		11.10	14.57	11.89	1.97	.47	.98	.87
300	318	12.72	12	332	420	352	60	15	30	22
	323,9	12.96		13.07	16.54	13.86	2.36	.59	1.18	.87
350	355,6	14.22	14	378	480	402	60	15	30	26
	368	14.72		14.88	18.90	15.83	2.36	.59	1.18	1.02
400	406,4	16.26	16	428	540	452	60	15	30	26
	419	16.76		16.85	21.26	17.80	2.36	.59	1.18	1.02
500	508	20.32	20	530	640	554	60	15	30	26
	521	20.84		20.87	25.20	21.81	2.36	.59	1.18	1.02

Order Codes

only Round Steel U-Bolt *RB*A 52*W1

One Round Steel U-Bolt (type RB) includes four Nuts (to DIN EN ISO 4032).

* Round Steel U-Bolt	RB
* Dimension A (mm)	A 52
* Material code	Carbon Steel, untreated W1
	Stainless Steel V4A W5
	1.4401 / 1.4571 (AISI 316 / 316 Ti)
	Carbon Steel, Plastic coated W6
	Carbon Steel, zinc-plated and thick-film passivated W66

only Plastic Pipe Saddle *RUL*48,3*PP

* Plastic Pipe Saddle (Long)	RUL
* Exact outside diameter Ø D1 (mm)	48,3
* Material of Pipe Saddle (see below)	PP

Standard Materials for Plastic Pipe Saddles

Polypropylene
Colour: Green
Material code: **PP**

Polyamide
Colour: Black
Material code: **PA**

See page A86 for material properties and technical information.

Alternative materials are available upon request. Please consult STAUFF for further information.

**Round Steel U-Bolt (without Plastic Pipe Saddle)
Type RBD**

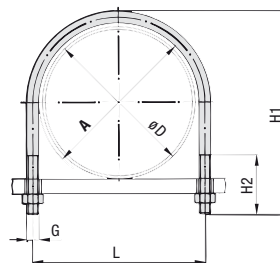

Round Steel U-Bolt (type RBD)

Order Codes

Clamp Assembly

***RBD*W1*A 30**

One clamp assembly is consisting of one Round Steel U-Bolt (type RBD) and two Nuts (to DIN EN ISO 4032).

* Clamp Assembly (as listed above)

RBD

* Material code Carbon Steel, untreated

W1

Carbon Steel, zinc-plated and thick-film passivated

W66

* Dimension A (mm)

A 30

Please note: All items are supplied non-assembled.

Diameter Nominal DN	Outside Diameter Pipe / Tube Ø D1		Nominal Bore Pipe (in)	Dimensions (mm/in)				
	(mm)	(in)		Round Steel U-Bolt (Type RBD)				Thread G
20	25	.98	3/4	30	40	70	40	
	26,9	1.06			1.57	2.76	1.57	
25	30	1.18	1	38	48	76	40	M10
	33,7	1.33			1.89	2.99	1.57	
32	38	1.50	1-1/4	46	56	86	50	M10
	42,4	1.69			1.81	2.20	3.39	
40	44,5	1.76	1-1/2	52	62	92	50	M10
	48,3	1.90			2.05	2.44	3.62	
50	57	2.28	2	64	76	109	50	M12
	60,3	2.41			2.52	2.99	4.29	
65	76,1	3.04	2-1/2	82	94	125	50	M12
80	88,9	3.56	3	94	106	138	50	M12
					3.70	4.17	5.43	
100	108	4.32	4	120	136	171	60	M12
	114,3	4.57			4.72	5.35	6.73	
125	133	5.32	5	148	164	191	60	M16
	139,7	5.59			5.83	6.46	7.52	
150	159	6.36	6	176	192	217	60	M16
	168,3	6.73			6.93	7.56	8.54	
175	193,7	7.75		202	218	249	60	M16
200	216	8.64	8	228	248	283	70	M20
	219,1	8.76			8.98	9.76	11.14	
250	267	10.68	10	282	303	334	70	M20
	273	10.92			11.10	11.89	13.15	
300	318	12.72	12	332	352	385	70	M20
	323,9	12.96			13.07	13.86	15.16	
350	355,6	14.22	14	378	402	435	70	M24
	368	14.72			14.88	15.83	17.13	
400	406,4	16.26	16	428	452	487	70	M24
	419	16.76			16.85	17.80	19.17	
500	508	20.32	20	530	554	589	70	M24
	521	20.84			20.87	21.81	23.19	

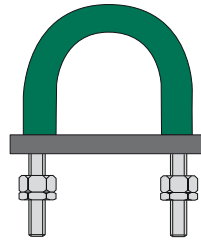

Rubber-Shrouded Round Steel U-Bolt Type RSU



Product Features

By preventing the direct metal-to-metal contact, STAUFF Rubber-Shrouded Round Steel U-Bolts, type RSU are primarily utilised in order to:

- Reduce or eliminate noise and fatigue due to vibration of pipework against the supporting structure
- Prevent galvanic corrosion due to the contact of dissimilar metals in the presence of an electrolyte
- Prevent wear and / or crushing of composite, thin-walled or non ferrous pipework and less resilient cabling

Applications

STAUFF Rubber-Shrouded Round Steel U-Bolts, type RSU have been developed over a number of years to meet the arduous and very specific requirements of process pipework and cabling engineers worldwide.

Materials

Standard material for STAUFF Rubber-Shrouded Round Steel U-Bolts, type RSU is Carbon Steel, electroplated with zinc. Both can also be supplied with alternative surface finishings, or can be manufactured from Stainless Steel, grades V2A and V4A. Consult STAUFF for further information.

STAUFF offers a wide range of shroud and pipe support materials that have been developed and selected to provide optimum performance over a wide range of applications.

Materials include a high-temperature Silicone based solution that is suitable for most applications within a temperature range of -60 °C ... +300 °C (-76 °F ... +572 °F) with excellent resistance to fire (flame rating of UL94-V0), very low toxicity and the ability to operate continuously at +300 °C (+572 °F) with only minimum loss of properties.

Please consult STAUFF and ask for detailed material specifications. Alternative materials are available upon request.

Sizes

STAUFF Rubber-Shrouded Round Steel U-Bolts, type RSU are available for almost all commonly used pipe and tube diameters, made of Steel, Stainless Steel, Copper as well as Cupro-Nickel:

- Nominal pipe sizes: up to DN 400
- Outside diameters: 21 mm ... 407 mm / .93 in ... 16.02 in

Approvals

STAUFF Rubber-Shrouded Round Steel U-Bolts, type RSU are particularly specified for use in Defence and Marine applications.

They have been tested and approved for bulk use in surface ships and sub-marines from a fire characteristics point of view according to Def Stan 07-247 („Selection of Materials on the Basis of their Fire Characteristics“) of the UK Ministry of Defence.

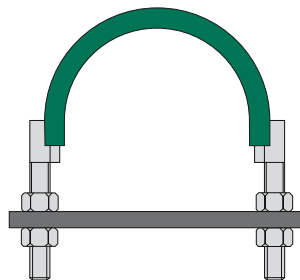

Rubber-Lined Flat Steel U-Bolt Type LUS

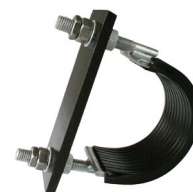

Product Features

By preventing the direct metal-to-metal contact, STAUFF Rubber-Lined Flat Steel U-Bolts, type LUS are primarily utilised in order to:

- Reduce or eliminate noise and fatigue due to vibration of pipework against the supporting structure
- Prevent galvanic corrosion due to the contact of dissimilar metals in the presence of an electrolyte
- Prevent wear and / or crushing of composite, thin-walled or non ferrous pipework and less resilient cabling

Applications

STAUFF Rubber-Lined Flat Steel U-Bolts, type LUS have been developed over a number of years to meet the arduous and very specific requirements of process pipework and cabling engineers worldwide.

Materials

Standard material for STAUFF Rubber-Lined Flat Steel U-Bolts, type LUS is Carbon Steel, electroplated with zinc. Both can also be supplied with alternative surface finishings, or can be manufactured from Stainless Steel, grades V2A and V4A. Consult STAUFF for further information.

STAUFF offers a wide range of shroud and pipe support materials that have been developed and selected to provide optimum performance over a wide range of applications.

Materials include a high-temperature Silicone based solution that is suitable for most applications within a temperature range of -60 °C ... +300 °C (-76 °F ... +572 °F) with excellent resistance to fire (flame rating of UL94-V0), very low toxicity and the ability to operate continuously at +300 °C (+572 °F) with only minimum loss of properties.

Please consult STAUFF and ask for detailed material specifications. Alternative materials are available upon request.

Sizes

STAUFF Rubber-Lined Flat Steel U-Bolts, type LUS are available for almost all commonly used pipe and tube diameters, made of Steel, Stainless Steel, Copper as well as Cupro-Nickel:

- Nominal pipe sizes: up to DN 700
- Outside diameters: 21 mm ... 740 mm / .93 in ... 29.13 in

Approvals

STAUFF Rubber-Lined Flat Steel U-Bolts, type LUS are particularly specified for use in Defence and Marine applications.

They have been tested and approved for bulk use in surface ships and sub-marines from a fire characteristics point of view according to Def Stan 07-247 („Selection of Materials on the Basis of their Fire Characteristics“) of the UK Ministry of Defence.

Metal Pipe Clamp with Rounded Ends

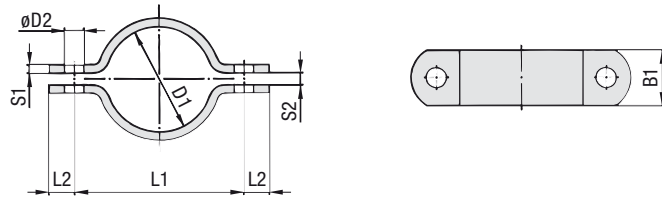

Order Codes

Clamp Assembly

***DIN 3567 A*-20*W1**

One clamp assembly is consisting of two clamp halves.
Hexagon head bolts and nuts are not included.

- * Clamp Assembly to DIN 3567, type A **DIN 3567 A**
- * STAUFF Group (Ø D1) **-20**
- * Material code Carbon Steel, untreated **W1**

STAUFF Group	Nominal Size	Dimensions (mm/in)							Accessories		
		Pipe (mm)	Pipe (in)	L1	L2	S1	S2	D2		B1	
20	15			57	15	5	7	11.5	30	M10 x 30 (M10) 3/8-16 UNC x 1-1/4 (3/8-16 UNC)	
				2.24	.59	.20	.28	.45	1.18		
22	15			59	15	5	7	11.5	30		
				2.32	.59	.20	.28	.45	1.18		
25	20			62	15	5	7	11.5	30		
				2.44	.59	.20	.28	.45	1.18		
27	20	3/4			66	15	5	7	11.5		30
					2.60	.59	.20	.28	.45		1.18
30	25			68	15	5	7	11.5	30		
				2.68	.59	.20	.28	.45	1.18		
34	25	1			72	15	5	7	11.5		30
					2.83	.59	.20	.28	.45		1.18
38	32			76	15	5	7	11.5	30		
				2.99	.59	.20	.28	.45	1.18		
43	32	1-1/4			82	15	5	7	11.5		30
					3.23	.59	.20	.28	.45		1.18
45	40			84	15	5	7	11.5	30		
				3.31	.59	.20	.28	.45	1.18		
49	40	1-1/2			88	15	5	7	11.5	30	
					3.46	.59	.20	.28	.45	1.18	
57	50			104	18	6	9	14	40	M12 x 35 (M12) 7/16-14 UNC x 1-3/8 (7/16-14 UNC)	
				4.09	.71	.24	.35	.55	1.57		
61	50	2			108	18	6	9	14		40
					4.25	.71	.24	.35	.55		1.57
77	65	2-1/2			122	18	6	9	14		40
					4.80	.71	.24	.35	.55		1.57
89	80	3			136	18	6	9	14		40
					5.35	.71	.24	.35	.55		1.57
108	100			172	24	8	11	18	50		M16 x 45 (M16) 5/8-11 UNC x 1-3/4 (5/8-11 UNC)
				6.77	.94	.31	.43	.71	1.97		
115	100	4			178	24	8	11	18	50	
					7.01	.94	.31	.43	.71	1.97	
133	125			196	24	8	11	18	50		
				7.72	.94	.31	.43	.71	1.97		
140	125			204	24	8	11	18	50		
				8.03	.94	.31	.43	.71	1.97		
159	150			222	24	8	11	18	50		
				8.74	.94	.31	.43	.71	1.97		
169	150			232	24	8	11	18	50		
				9.13	.94	.31	.43	.71	1.97		
194	175			258	24	8	11	18	50		
				10.16	.94	.31	.43	.71	1.97		
216	200			280	24	8	11	18	50		
				11.02	.94	.31	.43	.71	1.97		
220	200			284	24	8	11	18	50		
				11.18	.94	.31	.43	.71	1.97		
267	250			342	30	8	14	23	60	M20 x 50 (M20) 3/4-10 UNC x 2 (3/4-10 UNC)	
				13.46	1.18	.31	.55	.91	2.36		
273	250			348	30	8	14	23	60		
				13.70	1.18	.31	.55	.91	2.36		
318	300			392	30	8	14	23	60		
				15.43	1.18	.31	.55	.91	2.36		
324	300			398	30	8	14	23	60		
				15.67	1.18	.31	.55	.91	2.36		
368	350			444	30	8	14	23	60		
				17.48	1.18	.31	.55	.91	2.36		
407	400			498	36	10	18	27	70	M24 x 60 (M24) 7/8-9 UNC 2-3/8 (7/8-9 UNC)	
				19.61	1.42	.39	.71	1.06	2.76		
419	400			510	36	10	18	27	70		
				10.08	1.42	.39	.71	1.06	2.76		
521	500			614	36	10	18	27	70		
				24.17	1.42	.39	.71	1.06	2.76		

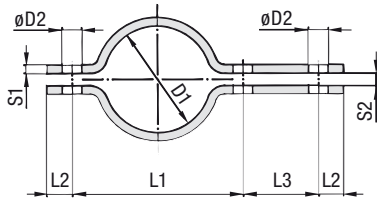
Metal Pipe Clamp with Rounded Ends and One-Side Elongated Shaft

STAUFF Group	Nominal Size		Dimensions (mm/in)						Accessories		
	Ø D1	Pipe (in)	L1	L2	L3	S1	S2	D2	B1	Hexagon Head Bolts (Hexagon Head Nuts)	
20	15		57	15	46	5	7	11.5	30	M10 x 30 (M10) 3/8-16 UNC x 1-1/4 (3/8-16 UNC)	
22			2.24	.59	1.81	.20	.28	.45	1.18		
25	20		62	15	46	5	7	11.5	30		
			2.44	.59	1.81	.20	.28	.45	1.18		
27	3/4		66	15	46	5	7	11.5	30		
			2.60	.59	1.81	.20	.28	.45	1.18		
30	25		68	15	46	5	7	11.5	30		
34			2.68	.59	1.81	.20	.28	.45	1.18		
38	32		72	15	46	5	7	11.5	30		
			2.83	.59	1.81	.20	.28	.45	1.18		
43	1-1/4		76	15	46	5	7	11.5	30		
			2.99	.59	1.81	.20	.28	.45	1.18		
45	40		82	15	46	5	7	11.5	30		
			3.23	.59	1.81	.20	.28	.45	1.18		
49	1-1/2		84	15	46	5	7	11.5	30		
			3.31	.59	1.81	.20	.28	.45	1.18		
57	50		88	15	46	5	7	11.5	30		
61			3.46	.59	1.81	.20	.28	.45	1.18		
57	50		104	18	54	6	9	14	40	M12 x 35 (M12) 7/16-14 UNC x 1-3/8 (7/16-14 UNC)	
			4.09	.71	2.13	.24	.35	.55	1.57		
61	50	2	108	18	54	6	9	14	40		
			4.25	.71	2.13	.24	.35	.55	1.57		
77	65	2-1/2	122	18	54	6	9	14	40		
			4.80	.71	2.13	.24	.35	.55	1.57		
89	80	3	136	18	54	6	9	14	40		
			5.35	.71	2.13	.24	.35	.55	1.57		
108	100		172	24	70	8	11	18	50		
			6.77	.94	2.76	.31	.43	.71	1.97		
115	100	4	178	24	70	8	11	18	50		
			7.01	.94	2.76	.31	.43	.71	1.97		
133	125		196	24	70	8	11	18	50		
			7.72	.94	2.76	.31	.43	.71	1.97		
140	125		204	24	70	8	11	18	50		
			8.03	.94	2.76	.31	.43	.71	1.97		
159	150		222	24	70	8	11	18	50	M16 x 45 (M16) 5/8-11 UNC x 1-3/4 (5/8-11 UNC)	
			8.74	.94	2.76	.31	.43	.71	1.97		
169	150		232	24	70	8	11	18	50		
			9.13	.94	2.76	.31	.43	.71	1.97		
194	175		258	24	70	8	11	18	50		
			10.16	.94	2.76	.31	.43	.71	1.97		
216	200		280	24	70	8	11	18	50		
			11.02	.94	2.76	.31	.43	.71	1.97		
220	200		284	24	70	8	11	18	50		
			11.18	.94	2.76	.31	.43	.71	1.97		
267	250		342	30	86	8	14	23	60		
			13.46	1.18	3.39	.31	.55	.91	2.36		
273	250		348	30	86	8	14	23	60		
			13.70	1.18	3.39	.31	.55	.91	2.36		
318	300		392	30	86	8	14	23	60		M20 x 50 (M20) 3/4-10 UNC x 2 (3/4-10 UNC)
			15.43	1.18	3.39	.31	.55	.91	2.36		
324	300		398	30	86	8	14	23	60		
			15.67	1.18	3.39	.31	.55	.91	2.36		
368	350		444	30	86	8	14	23	60		
			17.48	1.18	3.39	.31	.55	.91	2.36		
407	400		498	36	104	10	18	27	70		
			19.61	1.42	4.09	.39	.71	1.06	2.76		
419	400		510	36	104	10	18	27	70		
			10.08	1.42	4.09	.39	.71	1.06	2.76		
521	500		614	36	104	10	18	27	70		
			24.17	1.42	4.09	.39	.71	1.06	2.76		

Order Codes
Clamp Assembly
***DIN 3567 B*-20*W1**

One clamp assembly is consisting of two clamp halves. Hexagon head bolts and nuts are not included.

- * Clamp Assembly to DIN 3567, type B **DIN 3567 B**
- * STAUFF Group (Ø D1) **-20**
- * Material code Carbon Steel, untreated **W1**

Heavy Saddle ■ Single-Ended Design

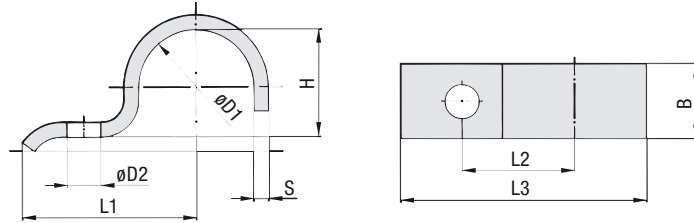

Order Codes

Heavy Saddle

DIN 1592-7*W66

* Heavy Saddle to DIN 1592

DIN 1592

* STAUFF Group (Ø D1)

-7

* Material code Carbon Steel, untreated

W1

Carbon Steel, zinc-plated and thick-film passivated

W66

STAUFF Group	Diameter Range		Dimensions (mm/in)						
	Ø D1 (mm)	(in)	L1	L2	L3	H	D2	B	S
7	5,5 ... 7	.2228	22	14	27,5	5	6,6	16	2
			.87	.55	1.08	.20	.26	.63	.08
9	7 ... 9	.2835	27	18	33,5	6	6,6	20	2
			1.06	.71	1.32	.24	.26	.79	.08
13	9,5 ... 13	.3951	40	25	49,5	9	11	25	3
			1.57	.98	1.95	.35	.43	.98	.12
15,5	13 ... 15,5	.5161	41	26	52	12	11	25	3
			1.61	1.02	2.05	.47	.43	.98	.12
19	15,5 ... 19	.6175	43	28	55,5	15	11	25	3
			1.69	1.10	2.19	.59	.43	.98	.12
23	20 ... 23	.7991	51	35	67	19	14	30	5
			2.01	1.38	2.64	.75	.55	1.18	.20
26	23 ... 26	.91 ... 1.02	52	36	70	22	14	30	5
			2.05	1.42	2.76	.87	.55	1.18	.20
28,5	26 ... 28,5	1.02 ... 1.12	53	37	73	24	14	30	5
			2.09	1.46	2.87	.94	.55	1.18	.20
31	28,5 ... 31	1.12 ... 1.22	55	39	75,5	27	14	30	5
			2.17	1.54	2.97	1.06	.55	1.18	.20
36	33 ... 36	1.30 ... 1.42	57	41	81	32	14	40	5
			2.24	1.61	3.19	1.26	.55	1.57	.20
39	36 ... 39	1.42 ... 1.54	59	43	83,5	34	14	40	5
			2.32	1.69	3.29	1.34	.55	1.57	.20
43	39 ... 43	1.54 ... 1.69	68	48	94,5	38	18	40	5
			2.68	1.89	3.72	1.50	.71	1.57	.20
46	43 ... 46	1.69 ... 1.81	70	50	98	41	18	40	5
			2.76	1.97	3.86	1.61	.71	1.57	.20
49	46 ... 49	1.81 ... 1.93	73	53	105,5	44	18	40	8
			2.87	2.09	4.15	1.73	.71	1.57	.31
52 *	49 ... 52	1.93 ... 2.05	76	56	110	47	18	40	8
			2.99	2.20	4.33	1.85	.71	1.57	.31
58	53 ... 58	2.09 ... 2.28	78	58	115	52	18	40	8
			3.07	2.28	4.53	2.05	.71	1.57	.31
61	58 ... 61	2.28 ... 2.40	80	60	118,5	57	18	40	8
			3.15	2.36	4.67	2.24	.71	1.57	.31

* Similar to DIN 1592.

Alternative materials and surface finishings are available upon request. Consult STAUFF for further information.

Heavy Saddle ▪ Double-Ended Design

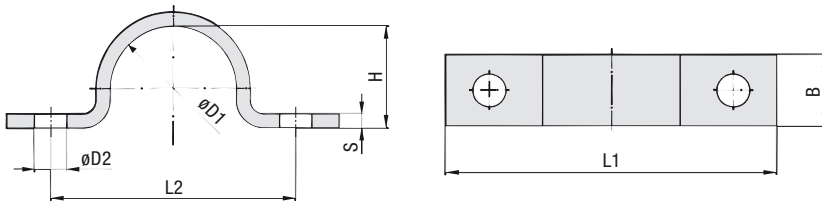

STAUFF Group	Diameter Range		Dimensions (mm/in)						
	Ø D1	(mm)	(in)	L1	L2	H	D2	B	S
7	5,5 ... 7	.2228	44	28	5	6,6	16	2	
			1.73	1.10	.20	.26	.63	.08	
9	7 ... 9	.2835	48	32	6	6,6	20	2	
			1.89	1.26	.24	.26	.79	.08	
13	9,5 ... 13	.3951	52	36	9	6,6	20	2	
			2.05	1.42	.35	.26	.79	.08	
15,5	13 ... 15,5	.5161	56	40	12	6,6	20	2	
			2.20	1.57	.47	.26	.79	.08	
19	15,5 ... 19	.6175	60	44	15	6,6	20	2	
			2.36	1.73	.59	.26	.79	.08	
23	20 ... 23	.7991	82	56	19	11	25	3	
			3.23	2.20	.75	.43	.98	.12	
26	23 ... 26	.91 ... 1.02	84	58	22	11	25	3	
			3.31	2.28	.87	.43	.98	.12	
28,5	26 ... 28,5	1.02 ... 1.12	90	64	24	11	25	3	
			3.54	2.52	.94	.43	.98	.12	
31	28,5 ... 31	1.12 ... 1.22	90	64	27	11	25	3	
			3.54	2.52	1.06	.43	.98	.12	
36	33 ... 36	1.30 ... 1.42	106	80	32	11	30	5	
			4.17	3.15	1.26	.43	1.18	.20	
39	36 ... 39	1.42 ... 1.54	110	84	34	11	30	5	
			4.33	3.31	1.34	.43	1.18	.20	
43	39 ... 43	1.54 ... 1.69	120	88	38	14	30	5	
			4.72	3.46	1.50	.55	1.18	.20	
46	43 ... 46	1.69 ... 1.81	122	90	41	14	30	5	
			4.80	3.54	1.61	.55	1.18	.20	
49	46 ... 49	1.81 ... 1.93	122	90	44	14	30	5	
			4.80	3.54	1.73	.55	1.18	.20	
58	53 ... 58	2.09 ... 2.28	142	110	52	14	40	5	
			5.59	4.33	2.05	.55	1.57	.20	
61	58 ... 61	2.28 ... 2.40	142	110	57	14	40	5	
			5.59	4.33	2.24	.55	1.57	.20	
71	67 ... 71	2.64 ... 2.80	152	120	66	14	40	5	
			5.98	4.72	2.60	.55	1.57	.20	
77	73 ... 77	2.87 ... 3.03	176	136	72	18	40	5	
			6.93	5.35	2.83	.71	1.57	.20	
81	77 ... 81	3.03 ... 3.19	184	144	76	18	40	5	
			7.24	5.67	2.99	.71	1.57	.20	
91	88 ... 91	3.39 ... 3.58	198	158	85	18	40	8	
			7.80	6.22	3.35	.71	1.57	.31	
103	99 ... 103	3.90 ... 4.06	214	174	98	18	40	8	
			8.43	6.85	3.86	.71	1.57	.31	
109	105 ... 109	4.13 ... 4.29	220	180	104	18	40	8	
			8.66	7.09	4.09	.71	1.57	.31	
115	110 ... 115	4.33 ... 4.53	226	186	109	18	40	8	
			8.90	7.32	4.29	.71	1.57	.31	

Order Codes

Heavy Saddle

DIN 1593-7*W66

* Heavy Saddle to DIN 1593

DIN 1593

* STAUFF Group (Ø D1)

-7

 * Material code Carbon Steel, untreated
Carbon Steel, zinc-plated
and thick-film passivated

W1

W66

Alternative materials and surface finishings are available upon request. Consult STAUFF for further information.

Light Saddle ■ Single-Ended Design

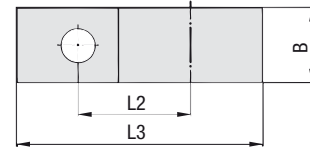
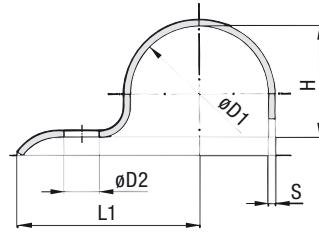

Order Codes

Light Saddle

DIN 1596-7*W66

* Light Saddle to DIN 1596

DIN 1596

* STAUFF Group (Ø D1)

-7

* Material code Carbon Steel, zinc-plated
and thick-film passivated

W66

STAUFF Group	Diameter Range		Dimensions (mm/in)						
	Ø D1 (mm)	(in)	L1	L2	L3	H	D2	B	S
7	5,5 ... 7	.2228	26	14	31,5	5	6,6	16	2
			1.02	.55	1.24	.20	.26	.63	.08
9	7 ... 9	.2835	28	16	34,5	6	6,6	16	2
			1.10	.63	1.36	.24	.26	.63	.08
13	9,5 ... 13	.3951	30	18	38,5	9	6,6	20	2
			1.18	.71	1.52	.35	.26	.79	.08
15,5	13 ... 15,5	.5161	32	20	41,75	12	6,6	20	2
			1.26	.79	1.64	.47	.26	.79	.08
19	15,5 ... 19	.6175	34	22	45,5	15	6,6	20	2
			1.34	.87	1.79	.59	.26	.79	.08
23	20 ... 23	.7991	43	28	57,5	19	9	25	3
			1.69	1.10	2.26	.75	.35	.98	.12
26	23 ... 26	.91 ... 1.02	44	29	60	22	9	25	3
			1.73	1.14	2.36	.87	.35	.98	.12
28,5	26 ... 28,5	1.02 ... 1.12	47	32	64,25	24	9	25	3
			1.85	1.26	2.53	.94	.35	.98	.12
31	28,5 ... 31	1.12 ... 1.22	47	32	65,5	27	9	25	3
			1.85	1.26	2.58	1.06	.35	.98	.12
33 *	31 ... 33	1.22 ... 1.30	56	36	75,5	29	9	25	3
			2.20	1.42	2.97	1.14	.35	.98	.12
36	33 ... 36	1.30 ... 1.42	57	40	78	32	11	30	3
			2.24	1.57	3.07	1.26	.43	1.18	.12
39	36 ... 39	1.42 ... 1.54	59	42	81,5	34	11	30	3
			2.32	1.65	3.21	1.34	.43	1.18	.12
43	39 ... 43	1.54 ... 1.69	61	44	85,5	38	11	30	3
			2.40	1.73	3.37	1.50	.43	1.18	.12
46	43 ... 46	1.69 ... 1.81	62	45	88	41	11	30	3
			2.44	1.77	3.46	1.61	.43	1.18	.12
49	46 ... 49	1.81 ... 1.93	67	48	95,5	44	14	40	4
			2.64	1.89	3.76	1.73	.55	1.57	.16
52 *	49 ... 52	1.93 ... 2.05	72	53	102	47	14	40	4
			2.83	2.09	4.02	1.85	.55	1.57	.16
58	53 ... 58	2.09 ... 2.28	76	55	107	52	14	40	4
			2.99	2.17	4.21	2.05	.55	1.57	.16
61	58 ... 61	2.28 ... 2.40	77	58	111,5	56	14	40	4
			3.03	2.28	4.39	2.20	.55	1.57	.16

* Similar to DIN 1596.

Alternative materials and surface finishings are available upon request. Consult STAUFF for further information.

Light Saddle ▪ Double-Ended Design

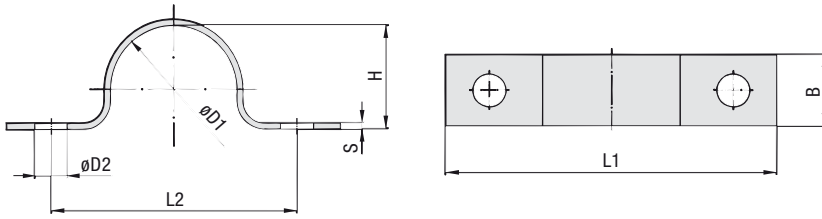

STAUFF Group	Diameter Range		Dimensions (mm/in)						
	Ø D1	(mm)	(in)	L1	L2	H	D2	B	S
7	5,5 ... 7	.2228	44	28	5	5,5	16	1,5	
			1.73	1.10	.20	.22	.63	.06	
9	7 ... 9	.2835	48	32	6	5,5	16	1,5	
			1.89	1.26	.24	.22	.63	.06	
13	9,5 ... 13	.3951	52	36	9	5,5	16	1,5	
			2.05	1.42	.35	.22	.63	.06	
15,5	13 ... 15,5	.5161	56	40	12	5,5	16	1,5	
			2.20	1.57	.47	.22	.63	.06	
19	15,5 ... 19	.6175	60	44	15	5,5	16	.5	
			2.36	1.73	.59	.22	.63	.02	
23	20 ... 23	.7991	76	44	19	6,6	20	2	
			2.99	1.73	.75	.26	.79	.08	
26	23 ... 26	.91 ... 1.02	78	56	22	6,6	20	2	
			3.07	2.20	.87	.26	.79	.08	
28,5	26 ... 28,5	1.02 ... 1.12	84	58	24	6,6	20	2	
			3.31	2.28	.94	.26	.79	.08	
31	28,5 ... 31	1.12 ... 1.22	84	64	27	6,6	20	2	
			3.31	2.52	1.06	.26	.79	.08	
33 *	31 ... 33	1.22 ... 1.30	92	72	29	6,6	20	2	
			3.62	2.83	1.14	.26	.79	.08	
36	33 ... 36	1.30 ... 1.42	104	80	32	9	25	3	
			4.09	3.15	1.26	.35	.98	.12	
39	36 ... 39	1.42 ... 1.54	108	84	34	9	25	3	
			4.25	3.31	1.34	.35	.98	.12	
43	39 ... 43	1.54 ... 1.69	112	88	38	9	25	3	
			4.41	3.46	1.50	.35	.98	.12	
46	43 ... 46	1.69 ... 1.81	114	90	41	9	25	3	
			4.49	3.54	1.61	.35	.98	.12	
49	46 ... 49	1.81 ... 1.93	118	90	44	11	30	3	
			4.65	3.54	1.73	.43	1.18	.12	
52 *	49 ... 52	1.93 ... 2.05	134	106	47	11	30	3	
			5.28	4.17	1.85	.43	1.18	.12	
58	53 ... 58	2.09 ... 2.28	138	110	52	11	30	3	
			5.43	4.33	2.05	.43	1.18	.12	
61	58 ... 61	2.28 ... 2.40	138	110	56	11	30	3	
			5.43	4.33	2.20	.43	1.18	.12	

Order Codes

Light Saddle

DIN 1597-7*W66

* Light Saddle to DIN 1597

DIN 1597

* STAUFF Group (Ø D1)

-7

* Material code Carbon Steel, zinc-plated and thick-film passivated

W66

* Similar to DIN 1597.

Alternative materials and surface finishings are available upon request. Consult STAUFF for further information.

Clamp Assembly - Types STC / SPC

(for Use with Channel Rail SCS)

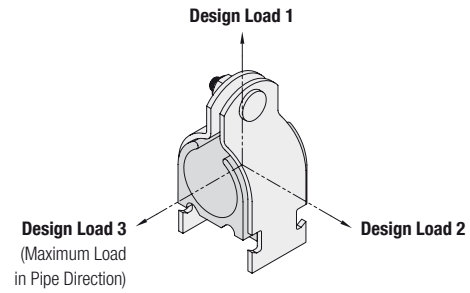
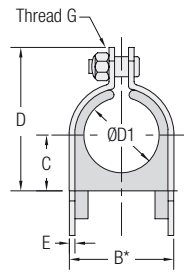

Outside Diameter Pipe / Tube / Hose Ø D1 (mm) (in)		Nominal Bore Pipe (in)	Order Codes (1 Clamp Assembly) (** = Material Code)	(1 Packaging Unit) (** = Material Code)	Standard Packaging Units pcs.	Dimensions (mm/in)					Design Loads (kN/psi)		
						B*	C	D	E	Thread G	1	2	3
6,4	1/4		STC 025 **	STC 025 ** - 024	24 / box	15,7 .62	5,6 0,22	28,2 1,11	2 .08	1/4-20 UNC	1,78 400	0,22 50	0,22 50
8	3/8		STC 037 **	STC 037 ** - 024	24 / box	19,1 .75	7,1 0,28	31,5 1,24	2 .08	1/4-20 UNC	1,78 400	0,22 50	0,22 50
12,7	1/2		STC 050 **	STC 050 ** - 024	24 / box	22,1 .87	8,6 0,34	34,5 1,36	2 .08	1/4-20 UNC	1,78 400	0,22 50	0,22 50
13,5		1/4	SPC 025 **	SPC 025 ** - 024	24 / box	23,1 .91	9,1 0,36	35,8 1,41	2 .08	1/4-20 UNC	1,78 400	0,22 50	0,22 50
16	5/8		STC 062 **	STC 062 ** - 024	24 / box	25,4 1,00	10,4 0,41	38,1 1,50	2 .08	1/4-20 UNC	1,78 400	0,22 50	0,22 50
17,2		3/8	SPC 037 **	SPC 037 ** - 024	24 / box	27,2 1,07	11,4 0,45	40,4 1,59	2 .08	1/4-20 UNC	2,67 600	0,33 75	0,33 75
19	3/4		STC 075 **	STC 075 ** - 024	24 / box	33,8 1,33	13,5 0,53	45,2 1,78	2 .08	1/4-20 UNC	2,67 600	0,33 75	0,33 75
21,3		1/2	SPC 050 **	SPC 050 ** - 024	24 / box	36,8 1,45	15,0 0,59	48,5 1,91	2 .08	1/4-20 UNC	2,67 600	0,33 75	0,33 75
22,2	7/8		STC 087 **	STC 087 ** - 024	24 / box	36,8 1,45	14,7 0,58	48,5 1,91	2 .08	1/4-20 UNC	2,67 600	0,33 75	0,33 75
25,4	1		STC 100 **	STC 100 ** - 012	12 / box	42,2 1,66	16,8 0,66	51,6 2,03	2,8 .11	1/4-20 UNC	2,67 600	0,33 75	0,33 75
26,9		3/4	SPC 075 **	SPC 075 ** - 012	12 / box	45,5 1,79	18,3 0,72	54,9 2,16	2,8 .11	1/4-20 UNC	2,67 600	0,33 75	0,33 75
32	1-1/4		STC 125 **	STC 125 ** - 012	12 / box	48,8 1,92	19,8 0,78	58,4 2,30	2,8 .11	1/4-20 UNC	2,67 600	0,33 75	0,33 75
33,7		1	SPC 100 **	SPC 100 ** - 012	12 / box	56,4 2,22	23,1 0,91	69,9 2,75	3 .12	5/16-18 UNC	2,67 600	0,33 75	0,33 75
38	1-1/2		STC 150 **	STC 150 ** - 012	12 / box	56,4 2,22	23,1 0,91	69,9 2,75	3 .12	5/16-18 UNC	2,67 600	0,33 75	0,33 75
42		1-1/4	SPC 125 **	SPC 125 ** - 012	12 / box	62,7 2,47	26,2 1,03	77,0 3,03	3 .12	5/16-18 UNC	3,56 800	0,56 125	0,56 125
48,3		1-1/2	SPC 150 **	SPC 150 ** - 012	12 / box	62,7 2,47	29,5 1,16	83,3 3,28	3 .12	5/16-18 UNC	3,56 800	0,56 125	0,56 125
50,8	2		STC 200 **	STC 200 ** - 012	12 / box	69,1 2,72	29,5 1,16	83,3 3,28	3 .12	5/16-18 UNC	3,56 800	0,56 125	0,56 125
60,3		2	SPC 200 **	SPC 200 **	1 / bag	69,1 3,22	35,8 1,41	96,0 3,78	3 .12	5/16-18 UNC	3,56 800	0,56 125	0,56 125
63,5	2-1/2		STC 250 **	STC 250 **	1 / bag	88,1 3,47	38,9 1,53	102,4 4,03	3 .12	5/16-18 UNC	3,56 800	0,56 125	0,56 125
66,7	2-5/8		STC 262 **	STC 262 **	1 / bag	88,1 3,47	38,9 1,53	102,4 4,03	3 .12	5/16-18 UNC	3,56 800	0,56 125	0,56 125
73		2-1/2	SPC 250 **	SPC 250 **	1 / bag	94,5 3,72	42,2 1,66	108,5 4,27	3 .12	5/16-18 UNC	3,56 800	0,56 125	0,56 125
76,2	3		STC 300 **	STC 300 **	1 / bag	100,8 3,97	45,2 1,78	114,8 4,52	3 .12	5/16-18 UNC	4,45 1 000	0,89 200	0,67 150
88,9		3	SPC 300 **	SPC 300 **	1 / bag	110,7 4,36	50,0 1,97	124,7 4,91	3 .12	3/8-16 UNC	4,45 1 000	0,89 200	0,67 150
102		3-1/2	SPC 350 **	SPC 350 **	1 / bag	126,2 4,97	57,9 2,28	140,5 5,53	3 .12	3/8-16 UNC	4,45 1 000	0,89 200	0,67 150
114		4	SPC 400 **	SPC 400 **	1 / bag	138,9 5,47	64,3 2,53	153,2 6,03	3 .12	3/8-16 UNC	4,45 1 000	0,89 200	0,67 150
140		5	SPC 500 **	SPC 500 **	1 / bag	164,3 6,47	77,0 3,03	178,6 7,03	3,6 .14	3/8-16 UNC	4,45 1 000	0,89 200	0,67 150
168		6	SPC 600 **	SPC 600 **	1 / bag	189,7 7,47	89,7 3,53	204,0 8,03	3,6 .14	3/8-16 UNC	4,45 1 000	0,89 200	0,67 150

* Minimum required for installation.

One clamp assembly is consisting of two carbon steel clamp halves (one with threaded stud), one thermoplastic cushion insert and one lock nut with Nylon insert. Channel rail not included. All threaded parts are only available with unified coarse (UNC) thread. Alternative materials and surface finishings are available upon request. Consult STAUFF for further information.

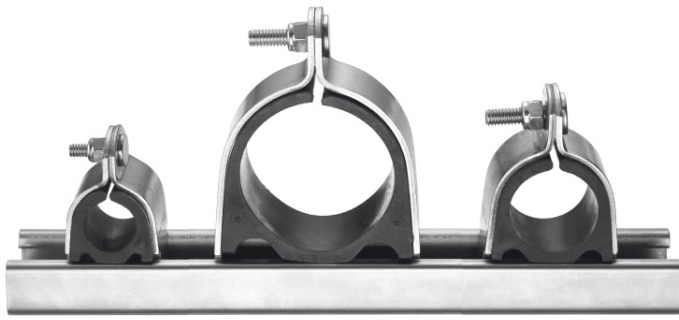
Clamp Assembly ■ Types STC / SPC

(for Use with Channel Rail SCS)

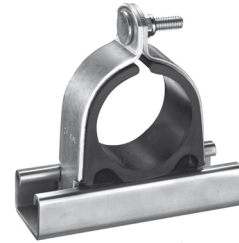
Standard Materials

Cushion Insert
Thermoplastic Elastomer (40 Shore-A)
Colour: Black

The cushion material is compatible with most oils, chemicals and cleaning solvents and suitable for applications within a temperature range of -50 °C ... +125 °C (-58 °F ... +257 °F).

Alternative materials are available upon request.
Please consult STAUFF for further information.

Product Features

- Clamp assemblies designed to mount directly to 41,3 mm / 1-5/8 in wide strut channels, such as the STAUFF Channel Rail, type SCS
- Suitable for most Fluid Power applications ranging from mobile equipment to industrial machinery
- Reduced horizontal mounting space
- Easy installation and retro fit capability
- Reduces shock and vibration while preventing galvanic corrosion

Order Codes
Clamp Assembly *STC*-125*-W4*-12*-*K

* Type of clamp	STC (Tube diameters) SPC (Pipe diameters)	STC SPC
* Pipe / Tube O.D. (according to dimension table)		-125
* Material code	Carbon Steel, zinc-plated, trivalent blue chromated	W3
	Stainless Steel V2A	W4
	1.4301 (AISI 304)	W4
	Stainless Steel V4A	W5
	1.4401 (AISI 316)	W5
* Box Quantity	Components for one assembly	-
	Components for 12 assemblies	12
	Components for 24 assemblies	24
	Please see dimension table for standard packaging units.	
Assembling	Components supplied separately	-
	Components packed in kits	#K

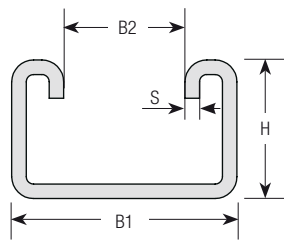
Channel Rail ■ Type SCS

Dimensions (mm/in)			
B1	B2	H	S
41,3	22,2	25,4	2,7
1.63 (1-5/8)	.88 (7/8)	1.00	.11

Alternative rail profiles, materials and surface finishings are available upon request. Consult STAUFF for further information.

Order Codes
Strut Channel *SCS*048*1*PL

* Strut Channel		SCS
* Length of Rail	1,22 m / 4.00 ft / 48 in 3,05 m / 10.00 ft / 120 in	048 120
* Height of Rail	25,4 mm / 1.00 in	1
* Material code	Carbon Steel, untreated	PL
	Carbon Steel, green painted	GR

Industry-Specific Solutions

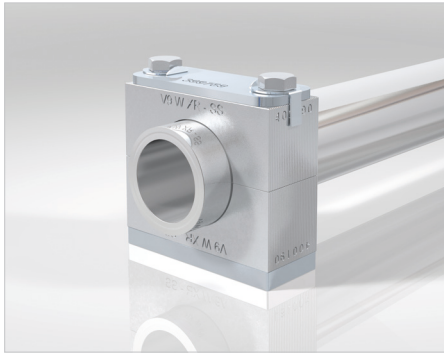

Power Plants

STAUFF offers a complete range of Plastic, Aluminium, Steel and Stainless Steel fastening elements for pipes, tubes and hoses in all temperature and pressure ranges, as well as for cables and other components in conventional power plants (lignite, hard coal, gas, water and others) and nuclear facilities.

With many years of experience and numerous references in equipping power plants and nuclear facilities both domestically and abroad, our portfolio ranges from the planning of individual fastening concepts, based on customer or industry-specific requirements, up to multi-stage logistics services.

- Fastening of pipes both as pipe slides, longitudinal guides or three-way stops
- Approvals and qualifications of KTA, RCC-M and ASME
- Suitability tested by the TÜV according to technical specifications and KTA 3205.3
- Identification of the products via a unique type-code
- Full tracing of all components and/or materials
- Provided with inspection documents 3.1 as per EN 10204



Wind Power Stations

In addition to the well-known, tried and tested STAUFF clamps for fastening all kind of industrial lines, we also offer industry-specific solutions for the orderly vertical installation of cables in wind power stations. When fastening these lines, special requirements are placed on the components, because the high weight of the cables must be held securely.

With many years of experience and numerous references in equipping wind power stations both domestically and abroad, our portfolio ranges from the planning of individual fastening concepts, based on customer or industry-specific requirements, up to multi-stage logistics services.

- Triangular design of the internal contours of the basic clamp body
- Accommodation of three cables with only a single cable support
- Additional adaptors can be optionally used to the extent that only two cables or lines with smaller external diameters can be fastened
- Fully flexible by always using an identical basic clamp body
- Installation in multiple layers and combination with other components and profiles
- Made of high-quality Plastics, also available in various custom materials in order to comply with international fire protection standards (e.g. with UL 94)

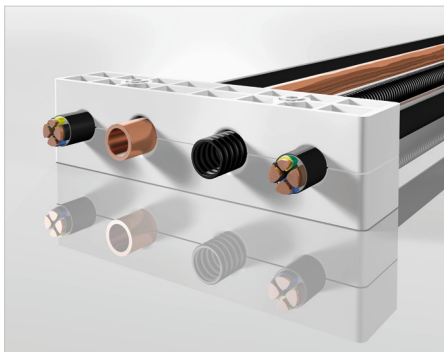

Rail Technology

In addition to the well-known, tried and tested STAUFF clamps for fastening all kind of industrial lines, we also offer industry-specific solutions for vibration and noise reducing and impact absorbing installations in rail technology related facilities.

With many years of experience and numerous references in the field of railway transportation system both domestically and abroad, our portfolio ranges from the planning of individual fastening concepts, based on customer or industry-specific requirements, up to multi-stage logistics services.

- Complete solution for all types of industrial lines
- Development in close collaboration with the customers
- Made of high-quality Plastics, also available in various custom materials in order to comply with international fire protection standards
- Amongst others, approvals based on several guidelines received, such as BS 6853, DIN 5510 - Part 2, NF F 16-101 or UL 94
- Depending on the quantities and the respective areas of application, mechanical or injection-moulded manufacturing
- Various fastening accessories made of steel and stainless steel

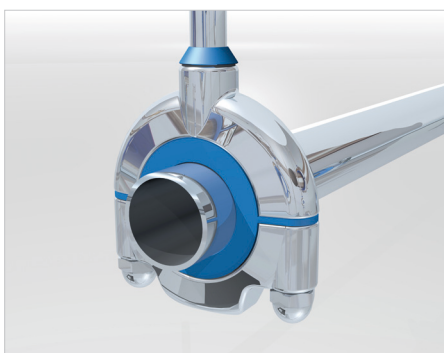

Process Technology

STAUFF Stainless Steel pipe clamps of the so-called Hi-Clean series were developed specifically for use in industrial clean rooms with the highest demands regarding hygiene and design. They are primarily used in the fields of process engineering and in the food, beverage and pharmaceuticals industry.

Our range of products for process technology applications is completed by the Hi-Clean pipe clamps of the Plastic series.

- Innovative, patent approved design
- Designed to comply with the specifications as defined by ASME-BPE, the American Society of Mechanical Engineers
- Suitable for pipes, tubes and other lines with outer diameters between 6,4 mm and 168,4 mm
- Rounded-off edges and corners to prevent dirt adhesion; no exposed threads or threads covered with acorn nuts
- All Plastic components comply with the specifications of the FDA (Food and Drug Administration of the United States)
- All metal components manufactured from corrosion-resistant stainless steel, upon request with electrolytically high-gloss polished material surfaces



Sub-Sea Pipelines

STAUFF Piggyback Sub-Sea Pipeline Saddles are the perfect solution for the installation of one or more additional supply lines (e.g. pipes, tubes or cables) on top of main sub-sea pipelines. Therefore, the most typical fields of application are in the off-shore oil and gas producing and processing industry.

Piggyback Saddles are always custom-designed according to customer's specifications or based on STAUFF developments and made out of Thermoplastics or Rubber materials (e.g. EPDM or Santoprene).

Depending on the design and the required quantities, they can be manufactured as machined or injection-moulded versions.

The actual saddles – tailored to the number, types and dimensions of the supply line(s) and the main pipeline – are secured by circumferential straps made out of Mild Steel, Inconel or Kevlar.

Mild Steel straps support the entire clamp assembly during the actual pipe-laying process. They later disintegrate in the seawater. The Inconel or Kevlar straps will remain in place and secure the clamp assembly on top of the main pipeline for time periods up to 20 years (depending on the surrounding conditions).

A combination of two different strap materials is commonly used to provide the best possible compromise between strength (required during the pipe-laying process) and longevity.

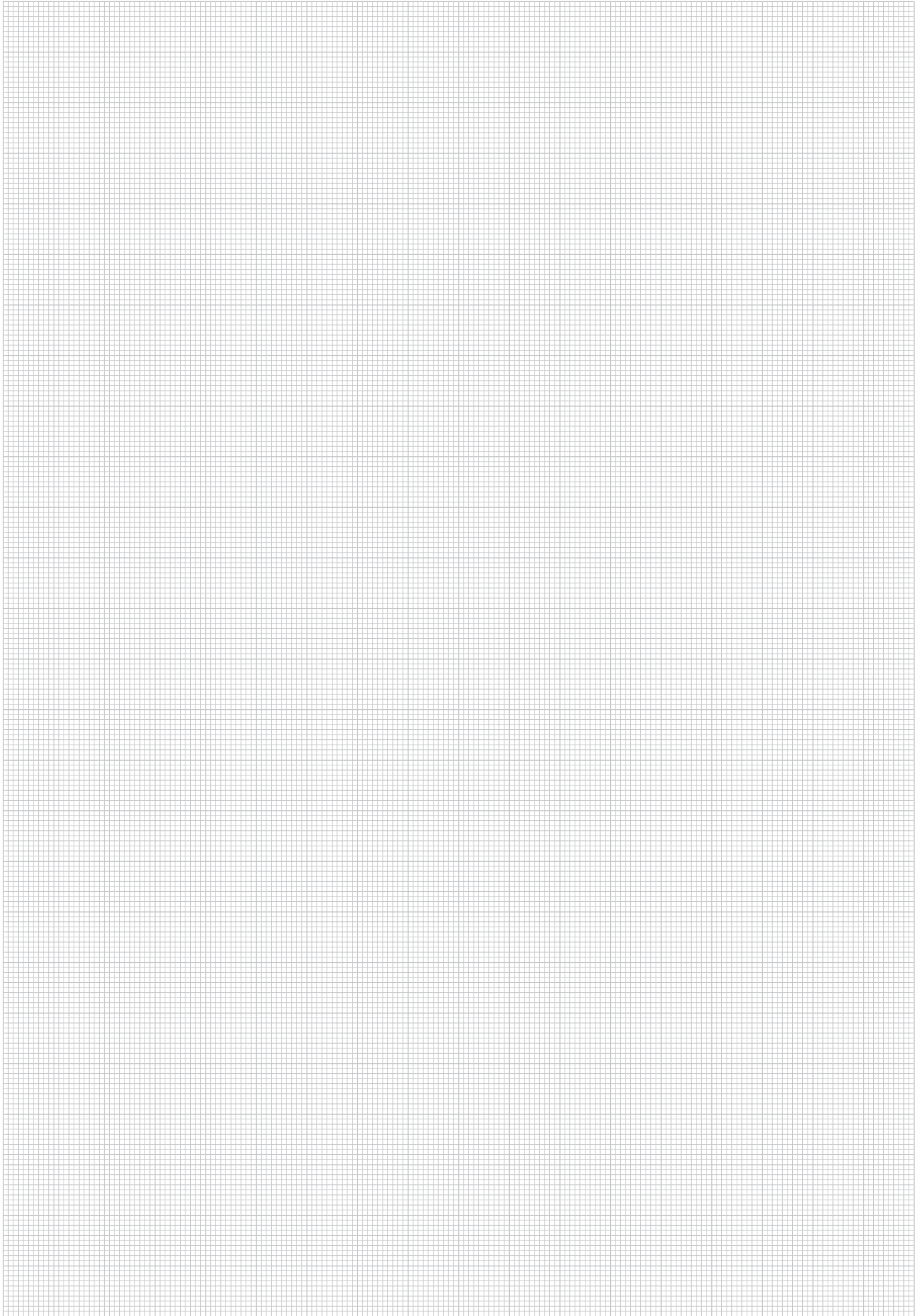

Standard Clamp Body Materials



Material Code	PP	PA	AL	SA
Basic Material	Copolymeric Polypropylene	Polyamide	Aluminium AISi12	Thermoplastic Elastomer
Standard Colour	Green	Black	Natural	Black

Mechanical Properties				
Tensile E-Module	1073 N/mm ² (ISO 527)	> 1400 N/mm ² (ISO 527)	> 65000 N/mm ²	113 N/mm ² at +23 °C / +73.4 °F (ASTM D412)
Notch Impact Strength	7,5 kJ/m ² at +23 °C / +73.4 °F (acc. to Charpy / ISO 179/1eA)	> 15 kJ/m ² at +23 °C / +73.4 °F (acc. to Charpy / ISO 179/1eA)		
Low Temperature Notch Impact Strength	3,1 kJ/m ² at -30 °C / -22.0 °F (acc. to Charpy / ISO 179/1eA)	> 3 kJ/m ² at -30 °C / -22.0 °F (acc. to Charpy / ISO 179/1eA)		
Tensile Strength at Yield (Tensile Strength)	25 N/mm ² (ISO 527)	> 55 N/mm ² (ISO 527)	> 150 N/mm ² (ISO EN 10002)	15,9 N/mm ² (ASTM D412)
Ball Indentation Hardness (Brinell Hardness)	45,4 N/mm ² (ISO 2039-1)	> 65 N/mm ² (ISO 2039-1)	> 55 HBS	
Shore Hardness				87 A (ISO 868)

Thermal Properties				
Temperature Resistance (Continuous Exposure, Min ... Max)	-30 °C ... +90 °C / -22 °F ... +194 °F	-40 °C ... +120 °C / -40 °F ... +248 °F (Brief exposure up to +140 °C / +284 °F)	up to +300 °C / up to +572 °F	-40 °C ... +125 °C / -40 °F ... +257 °F

Chemical Properties				
Weak Acids	conditionally consistent	conditionally consistent	conditionally consistent	consistent
Solvents	conditionally consistent	conditionally consistent	conditionally consistent	conditionally consistent
Benzine	conditionally consistent	consistent	consistent	conditionally consistent
Mineral Oils	conditionally consistent	consistent	consistent	conditionally consistent
Other Oils	consistent	consistent	consistent	consistent
Alcohols	consistent	consistent	consistent	consistent
Seawater	consistent	consistent	consistent	consistent

The information for the Polyamide material PA and the Polyamide based materials PAVO and PA-FF have been determined in a conditioned state according to ISO 1110. For Aluminium, the tensile strength (under reversed bending stress) and impact bending strength both rise constantly at decreasing temperatures whilst the value for breaking elongation decreases.

Standard Rubber Insert Materials



Thermoplastic Elastomer (73 Shore-A)

Standard Material for STAUFF Group 4 and 6 (Standard Series)
Standard Material for STAUFF Group 4S to 6S (Heavy Series)

Mechanical Properties

Shore Hardness: 73 A (ISO 868)
Modulus of Elasticity: 16 N/mm² at +23 °C / +73.4 °F
(ASTM D 412)
Tensile Stress: 8,3 N/mm² (ASTM D 412)

Thermal Properties

Temperature Resistance: -40 °C ... +125 °C / -40 °F ... +257 °F

Chemical Properties

Consistent against weak acids and solvents;
conditionally consistent against benzine and mineral oils;
consistent against other oils, alcohols and sea water.

Elastomer (70 Shore-A)

Standard Material for STAUFF Group 7S to 10S (Heavy Series)

Mechanical Properties

Shore Hardness: 70 A (DIN 53505)
Tensile Strength at Yield: 9 N/mm² (DIN 53504)
Tensile Strain at Break: 400% (DIN 53504)
Tear-Growth Resistance: 9 N/mm (DIN 53507-A)
Compression Set: 20% (DIN 53517)
(22 h at +70 °C / +158 °F)

Consult STAUFF for further information.

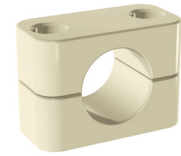
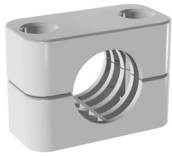
Special Clamp Body Materials (Selection)
 Preventive Fire Protection / Corrosion Prevention

PAVO	PA-FF	PPDA	PP6853	PP-AC
Polyamide	Polyamide	Polypropylene	Polypropylene	Polypropylene
Grey	Black	White	White	Natural / Uncoloured

1500 N/mm ² (ISO 527-1/2)	1100 N/mm ² (ISO 527-1/2)	2200 N/mm ² (ISO 527) at +23 °C / +73.4 °F: 50 mm/min	1440 N/mm ² (ICE 60811-1-1)	1073 N/mm ² (ISO 527)
35 kJ/m ² at +23 °C / +73.4 °F (acc. to Charpy / ISO 179/1eA)	20 kJ/m ² at +23 °C / +73.4 °F (acc. to Charpy / ISO 179/1eA)	11,8 kJ/m ² at +23 °C / +73.4 °F (acc. to IZOD / ISO 179/1eA)	16 kJ/m ² at +23 °C / +73.4 °F (acc. to IZOD / ISO 179/1eA)	7,5 kJ/m ² at +23 °C / +73.4 °F (acc. to Charpy / ISO 179/1eA)
		4,9 kJ/m ² at -25 °C / -13.0 °F (acc. to IZOD / ISO 179/1eA)		3,1 kJ/m ² at -30 °C / -22.0 °F (acc. to Charpy / ISO 179/1eA)
45 N/mm ² (ISO 527-1/2)	50 N/mm ² (ISO 527-1/2)	15,1 N/mm ² (ISO 527) at +23 °C / +73.4 °F: 50 mm/min	20,4 N/mm ² (ICE 60811-1-1)	25 N/mm ² (ISO 527)
100 N/mm ² (ISO 2039-1)	100 N/mm ² (ISO 2039-1)			45,4 N/mm ² (ISO 2039-1)

-30 °C ... +120 °C / -22 °F ... +248 °F	-30 °C ... +120 °C / -22 °F ... +248 °F	-25 °C ... +90 °C / -13 °F ... +194 °F	-25 °C ... +90 °C / -13 °F ... +194 °F	-30 °C ... +90 °C / -22 °F ... +194 °F
---	---	--	--	--

Approvals / Special Properties				
<p>Tested and approved according to UL94 (Vertical Burning Test)</p> <ul style="list-style-type: none"> Classification: 94V-0 (thickness: 0,4mm) <p>Tested and approved according to DIN 5510, Part 2</p> <ul style="list-style-type: none"> Combustibility classification: S3 Smoke development classification: SR2 Dripping classification: ST2 <p>Tested and approved according to NF F 16-101</p> <ul style="list-style-type: none"> Classification: I2 / F2 <p>Halogen- and phosphor-free flame retardant system</p> <p>Oxygen index: 34,0% (according to ISO 4589-2)</p> <p>Flammability temperature: 299 °C / 570 °F (according to ISO 4589-3, Annex A)</p> <p>High durability, good UV, weathering and chemical resistance</p>	<p>Tested and approved according to DIN 5510, Part 2</p> <ul style="list-style-type: none"> Combustibility classification: S4 Smoke development classification: SR2 Dripping classification: ST2 <p>Oxygen index: 28,0% (according to ISO 4589-2)</p> <p>Flammability temperature: 327 °C / 621 °F (according to ISO 4589-3, Annex A)</p> <p>High durability (even at low temperatures), mechanical strength and rigidity, good attrition resistance and fatigue strength, good UV resistance</p>	<p>Tested and approved according to Def Stan 07-247</p> <ul style="list-style-type: none"> Assessment: category B <p>Approved by the UK Ministry of Defence (MoD)</p> <p>Smoke index: 11,1% (according to Def Stan 02-711, thickness: 3,0 mm)</p> <p>Halogen-free flame retardant system</p> <p>Toxicity index: 0,9 / 100 g (according to Def Stan 02-713)</p> <p>Oxygen index: 30,9% (according to ISO 4589-2)</p> <p>Flammability temperature: 231 °C / 448 °F (according to ISO 4589-3, Annex A)</p>	<p>Tested and approved according to BS 6853 (Code of practice for fire precautions in the design/construction of passenger carrying trains)</p> <ul style="list-style-type: none"> Assessment: category 1a <p>Compliant to the requirements of London Underground / Metronet (standard 2-01001-002: Fire Safety Performance of Materials)</p> <p>Tested and approved according to DIN 5510, Part 2</p> <ul style="list-style-type: none"> Combustibility classification: S3 Smoke development classification: SR2 Dripping classification: ST2 <p>Tested and approved according to Def Stan 07-247</p> <ul style="list-style-type: none"> Assessment: category B <p>Smoke index: 6,1% (according to Def Stan 02-711, thickness: 3,0 mm)</p> <p>Halogen-free flame retardant system</p> <p>Toxicity index: 0,9 / 100 g (according to Def Stan 02-713)</p> <p>Oxygen index: 42,0% (according to ISO 4589-2)</p> <p>Flammability temperature: 325 °C / 617 °F (according to ISO 4589-3, Annex A)</p>	<p>Successfully tested in salt spray cabinet trials according to ISO 9227 / ASTM B117</p> <ul style="list-style-type: none"> Delays the formation of crevice corrosion by depositing a special corrosion protection inhibitor (which is added to the basic PP material during production) in the gap between clamp body and stainless steel pipe Lengthens maintenance intervals Minimises servicing requirements and costs Delivers tremendous potential savings

Standard Clamp Body Designs

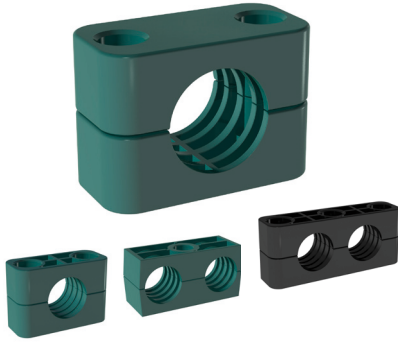

Profiled Design

Profiled Inside Surface with Tension Clearance

- Available in the Standard, Heavy, Twin and Heavy Twin Series
- Recommended for the safe installation of rigid pipes or tubes
- Available for all commonly used outside diameters and nominal sizes
- Vibration/noise reducing and impact absorbing effect towards the direction of the line provided by the grooves on the inside of the clamp bodies
- To be used as fixed point clamp preventing the line from sliding (see page A91 for Maximum Loads in Pipe Direction)
- Clearance between the clamp halves provides tension of the tube or pipe

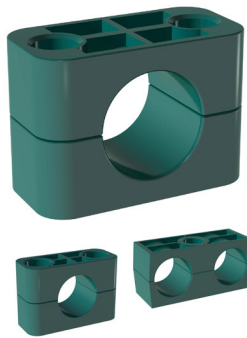

Type H (Smooth)

Smooth Inside Surface w/o Tension Clearance

- Available in the Standard, Heavy and Twin Series
- Recommended for the safe installation of hoses or cables
- Available for all commonly used outside diameters and nominal sizes
- Smooth inside surface and chamfered edges avoid damaging of the hose or cable
- To be used as guide allowing the line to slide
- Choose internal diameter of the clamp body slightly smaller than the outside diameter of the hose or cable to use it as fixed point clamp preventing the line from sliding



Type RI (with Rubber Insert)

- Available in the Standard, Heavy and Heavy Twin Series
- Recommended for the extra-gentle installation of pipes, tubes, hoses or cables
- Available for all commonly used outside diameters and nominal sizes
- Rubber insert made of Thermoplastic Elastomer with a hardness of 73 Shore-A provides most effective reduction of vibration and noise caused by vibration

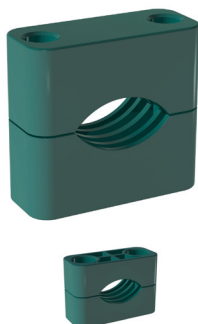

Oval Design

- Available in the Standard and Heavy Series
- Recommended for the safe installation of electric cables with diameters between 20 mm (.79 in) and 72 mm (2.83 in)

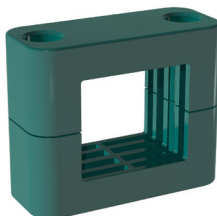

Rectangular Design ▪ Type VK

- Available in the Standard Series (STAUFF Group 5)
- Recommended for the safe installation of proximity switches according to DIN EN 60947-5-2 or similar, rectangular construction, with a square of 40 mm x 40 mm (1.57 in x 1.57 in) or 40 mm x 36 mm (1.57 in x 1.42 in)

Materials and Surface Finishings of Metal Parts

Materials

Unless otherwise stated, all metal parts (e.g. weld plates, cover plates, bolts, rail nuts, etc.) are made of **Carbon Steel St37** (surface finishing according to material code).

Besides that, all metal parts are also available **ex stock** in two different stainless steel qualities:

Stainless Steel V2A

- 1.4301 / 1.4305 (AISI 304 / 303)
- Material code: W4



Stainless Steel V4A

- 1.4401 / 1.4571 (AISI 316 / 316 Ti)
- Material code: W5

Alternative materials are available upon request. Consult STAUFF for further information.

Surface Finishings

Unless otherwise stated, all metal parts made of Carbon Steel St37 are available with the following standard surface finishings:

Carbon Steel St37, untreated

- Material code: W1

Carbon Steel St37, phosphated

- Fe/Znph r 10 according to DIN EN 12476
- Material code: W2

Carbon Steel St37, zinc/nickel-plated

- Fe/ZnNi (12...16) 6+6//A//T2 according to DIN 50962
- More than 720 hours resistance against red rust / base metal corrosion in the salt spray test to DIN EN ISO 9227
- Free of hexavalent chromium Cr(VI)
- RoHS compliant according to 2002/95/EC (Restrictions of the Use of Hazardous Substances)
- ELV compliant according to 2000/53/EC (End of Life Vehicles Directive)
- Material code: W3

Alternative surface finishings are available upon request. Consult STAUFF for further information.



Original STAUFF Cover Plate with Zinc/Nickel-Coating: No signs of corrosion after **528 hours** in the salt spray chamber!



Original STAUFF Cover Plates with alternative surface finishings widely-used by competitors in the market (from left to right):

- Galvanisation and blue-chromating after **96 hours**
- Galvanisation and yellow-chromating after **192 hours**
- Zinc-coating, thick-film passivation and sealing after **192 hours**

In all three cases, signs of corrosion are quite clearly visible!

Consult STAUFF and ask for a detailed report.

Thread Conversion Chart

Metric ISO vs. Unified Coarse (UNC) Thread

Unless otherwise stated, all threaded parts available with Metric ISO thread or unified coarse (UNC) thread.

Standard Series (DIN 3015, Part 1)

Group STAUFF	DIN	Thread Metric ISO	Unified Coarse
1 to 8	0 to 8	M6	1/4–20 UNC

Heavy Series (DIN 3015, Part 2)

Group STAUFF	DIN	Thread Metric ISO	Unified Coarse
3S to 5S	1 to 3	M10	3/8–16 UNC
6S	4	M12	7/16–14 UNC
7S	5	M16	5/8–11 UNC
8S	6	M20	3/4–10 UNC
9S	7	M24	7/8–9 UNC
10S	8	M30	1-1/8–7 UNC
11S to 12S	9 to 10	M30	1-1/4–7 UNC

Twin Series (DIN 3015, Part 3)

Group STAUFF	DIN	Thread Metric ISO	Unified Coarse
1D	1	M6	1/4–20 UNC
2D to 5D	2 to 5	M8	5/16–18 UNC

Property Classes / Grades of Bolts and Screws



Hexagon Head Bolt

Socket Cap Screw

Slotted Head Screw

Bolt / Screw Type	Material Code	Property Class / Grade	
		Metric ISO Threaded Bolts / Screws	Unified Coarse Threaded Bolts / Screws
Hexagon Head Bolt Type AS	W1, W2, W3	8.8 (according to DIN EN ISO 898)	5 (according to SAE J429)
	W4	A2-70 (according to DIN EN ISO 3506)	AISI 304 / B8 (according to ASTM A193)
	W5	A4-70 (according to DIN EN ISO 3506)	AISI 316 / B8M (according to ASTM A193)
Socket Cap Screw Type IS	W1, W2, W3	8.8 (according to DIN EN ISO 898)	5 (according to SAE J429)
	W4	A2-70 (according to DIN EN ISO 3506)	AISI 304 / B8 (according to ASTM A193)
	W5	A4-70 (according to DIN EN ISO 3506)	AISI 316 / B8M (according to ASTM A193)
Slotted Head Screw Type LI	W1, W2, W3	4.8 (according to DIN EN ISO 898)	2 (according to SAE J429)
	W4	A2-70 (according to DIN EN ISO 3506)	AISI 304 / B8 (according to ASTM A193)
	W5	A4-70 (according to DIN EN ISO 3506)	AISI 316 / B8M (according to ASTM A193)

Unless otherwise stated, the above mentioned property classes / grades apply as standards for bolts and screws supplied by STAUFF. The information indicate the minimum requirements; higher property classes are available upon request. Consult STAUFF for details.

Basic Installation Instructions



Installation on Weld Plate

Different types of weld plates are available for all STAUFF Clamps according to DIN 3015 as well as for most of the other series and many custom-designed special clamps.

- Place weld plates in their designated positions. Please make sure these positions are suitable for the expected loads.
- Mark the locations of the weld plates to ensure best alignment.
- Weld the weld plates into position. Elongated weld plates can also be mounted to their positions by using screws or bolts.
- Push bottom clamp half onto weld plate.
- Insert pipe, tube, hose, cable or any other line type.
- Place second clamp half and cover plate (optional) on top and mount clamp assembly by using screws or bolts.

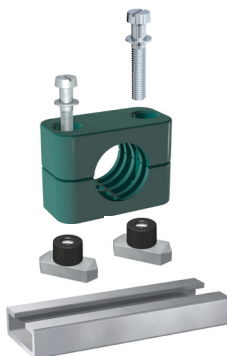

Installation on Mounting Rail

STAUFF Mounting Rails are available in different heights. STAUFF Rail Nuts are available for all STAUFF Clamps according to DIN 3015 (Heavy Series up to STAUFF Group 6S only) as well as for many custom-designed special clamps.

- Place mounting rails in their designated positions. Please make sure these bases are suitable for the expected loads.
- Mark the locations of the mounting rails to ensure best alignment.
- Weld the mounting rails into position. Mounting rails can also be mounted to their positions by using side-mounting brackets with screws or bolts.
- Insert rail nuts into mounting rail and turn until stop to lock (Standard and Twin Series) or slide in rail nut (Heavy Series).
- Push bottom clamp half onto rail nuts.
- Insert pipe, tube, hose, cable or any other line type.
- Place second clamp half and cover plate (optional) on top and mount clamp assembly by using screws or bolts.

The exact positions of the clamp assemblies can still be adjusted before being firmly bolted.



Multi-Level (Stacking) Installation

The multi-level installation of STAUFF Clamps permits easy stacking of several pipes, tubes, hoses, cables or any other line types, even with different outside diameters. The Twin Series also allows stacking of different group sizes (STAUFF Groups 2D to 5D).

The clamps are connected by stacking bolts. Safety locking plates inserted between the clamps prevent stacking bolts from turning.

- Push bottom clamp half onto weld plate or rail nuts.
- Insert pipe, tube, hose, cable or any other line type.
- Place second clamp half mount clamp assembly by using stacking bolts.
- Place safety locking plate on top of clamp assembly to prevent stacking bolts from turning.
- Proceed with next level as explained before.

STAUFF multi-level clamp assemblies can be mounted both to weld plates or to mounting rails.

Recommended Distance between Clamps

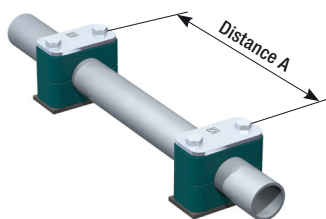

Please note: The recommended distances between clamps stated below are standard values and valid for static loads only.

Outside Diameter (mm)	(in)	Distance A (m)	(ft)
6,0 ... 12,7	.2350	1,00	3,28
12,7 ... 22,0	.5086	1,20	3,94
22,0 ... 32,0	.86 ... 1.25	1,50	4,92
32,0 ... 38,0	1.25 ... 1.50	2,00	6,56
38,0 ... 57,0	1.5 ... 2.25	2,70	8,86
57,0 ... 75,0	2.25 ... 2.95	3,00	9,84
75,0 ... 76,1	2.95 ... 3.00	3,50	11,48
76,1 ... 88,9	3.00 ... 3.50	3,70	12,14
88,9 ... 102,0	3.50 ... 4.00	4,00	13,12
102,0 ... 114,0	4.00 ... 4.50	4,50	14,76

Installation next to Pipe Bends, Connectors / Couplings and Valves

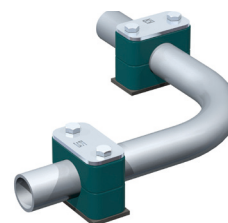

Please note the following information on the installation of STAUFF Clamps next to pipe bends, connectors / couplings and valves:

Pipe Bends

Pipe bends should be supported by STAUFF Clamps as close to the bends as possible. Furthermore, it is recommended to design these clamps as fixed point clamps.

Connections / Couplings

The first clamp should be placed directly next to the connector / coupling. This protects the connector / coupling from vibrations.

Valves

If valves are incorporated in the pipelines, it is recommended that support is provided in front of and behind these valves.

Consult STAUFF for further information.

Tightening Torques and Maximum Loads In Pipe Direction

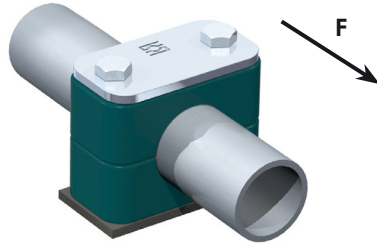

All tightening torques and maximum loads in pipe direction refer to STAUFF Clamp Bodies (profiled inside surface with tension clearance) with Cover Plates and Hexagon Head Bolts according to DIN EN ISO 4014/4017 (DIN 931/933).

The max. load in pipe direction (according to DIN 3015, Part 10) is an average value, determined by three tests at +23 °C / +73.4 °F with a steel pipe according to DIN EN 10220, St37 – rolled surface – taking static friction into consideration.

Standard Series (DIN 3015, Part 1)

Sliding starts when the shown values (F) are reached.

Group		Hexagon Head Bolt DIN EN ISO 4014/4017 (DIN 931/933)		Polypropylene				Polyamide				Aluminium			
STAUFF	DIN	Metric ISO Thread	Unified Coarse (UNC) Thread	Tightening Torque (N-m) (ft-lb)		Maximum Load in Pipe Direction F (kN) (lbf)		Tightening Torque (N-m) (ft-lb)		Maximum Load in Pipe Direction F (kN) (lbf)		Tightening Torque (N-m) (ft-lb)		Maximum Load in Pipe Direction F (kN) (lbf)	
1	0	M6	1/4-20 UNC	8	6	0,6	135	10	7	0,6	135	12	9	3,5	787
1A	1	M6	1/4-20 UNC	8	6	1,1	247	10	7	0,7	157	12	9	4,2	944
2	2	M6	1/4-20 UNC	8	6	1,3	292	10	7	0,8	180	12	9	4,3	967
3	3	M6	1/4-20 UNC	8	6	1,4	315	10	7	1,6	360	12	9	4,9	1101
4	4	M6	1/4-20 UNC	8	6	1,5	337	10	7	1,7	382	12	9	5,0	1124
5	5	M6	1/4-20 UNC	8	6	1,9	427	10	7	2,0	450	12	9	7,3	1641
6	6	M6	1/4-20 UNC	8	6	2,0	450	10	7	2,5	562	12	9	8,9	2000
7	7	M6	1/4-20 UNC	8	6	2,3	517	10	7	3,2	719	NOT AVAILABLE!			
8	8	M6	1/4-20 UNC	8	6	2,6	585	10	7	3,5	787				

Heavy Series (DIN 3015, Part 2)

Group		Hexagon Head Bolt DIN EN ISO 4014/4017 (DIN 931/933)		Polypropylene				Polyamide				Aluminium			
STAUFF	DIN	Metric ISO Thread	Unified Coarse (UNC) Thread	Tightening Torque (N-m) (ft-lb)		Maximum Load in Pipe Direction F (kN) (lbf)		Tightening Torque (N-m) (ft-lb)		Maximum Load in Pipe Direction F (kN) (lbf)		Tightening Torque (N-m) (ft-lb)		Maximum Load in Pipe Direction F (kN) (lbf)	
3S	1	M10	3/8-16 UNC	12	9	1,6	360	20	15	4,2	944	30	22	12,1	2720
4S	2	M10	3/8-16 UNC	12	9	2,9	652	20	15	4,5	1044	30	22	15,1	3395
5S	3	M10	3/8-16 UNC	15	11	3,3	742	25	18	5,1	1146	35	26	15,5	3485
6S	4	M12	7/16-14 UNC	30	22	8,2	1843	40	30	9,3	2090	55	41	29,5	6609
7S	5	M16	5/8-11 UNC	45	33	11,0	2472	55	41	25,8	5800	120	86	34,9	7845
8S	6	M20	3/4-10 UNC	80	59	14,0	3147	150	111	21,0	4720	220	162	50,0	11240
9S	7	M24	7/8-9 UNC	110	81	28,0	6300	200	148	32,0	7193	250	184	70,6	15871
10S	8	M30	1-1/8-7 UNC	180	133	40,0	8992	350	258	48,0	10790	500	369	84,5	18996
11S	9	M30	1-1/4-7 UNC	200	148	119,0	26752	370	273	125,0	27650	500	369	181,5	40802
12S	10	M30	1-1/4-7 UNC	270	199	168,0	37767	450	332	180,0	40465	600	443	244,5	54965

Twin Series (DIN 3015, Part 3)

Group		Hexagon Head Bolt DIN EN ISO 4014/4017 (DIN 931/933)		Polypropylene				Polyamide			
STAUFF	DIN	Metric ISO Thread	Unified Coarse (UNC) Thread	Tightening Torque (N-m) (ft-lb)		Maximum Load in Pipe Direction F (kN) (lbf)		Tightening Torque (N-m) (ft-lb)		Maximum Load in Pipe Direction F (kN) (lbf)	
1D	1	M6	1/4-20 UNC	5	4	0,9	202	5	4	0,9	202
2D	2	M8	5/16-18 UNC	12	9	2,1	472	12	9	2,2	495
3D	3	M10	5/16-18 UNC	12	9	1,9	427	12	9	2,0	450
4D	4	M12	5/16-18 UNC	12	9	2,7	607	12	9	2,9	652
5D	5	M16	5/16-18 UNC	8	6	1,7	382	8	6	2,5	562

Dimensions and Weights of Clamp Assemblies

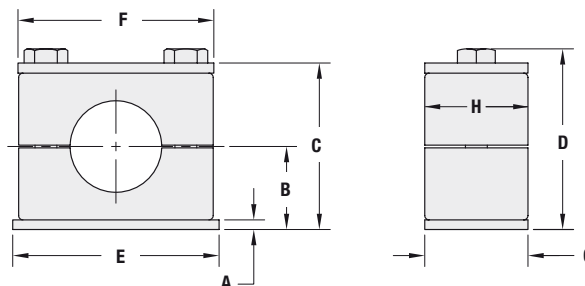

Standard Series (DIN 3015, Part 1)

Group	STAUFF	DIN	Dimensions (mm/in)								Weight per 100 Pcs.		
			A	B		C		D		E	F	G	H
		Profiled Design		Type H (Smooth)		Profiled Design		Type H (Smooth)					
1	0	3	16,5	16	33	32	37	36	31,5	28	30	30	6,20
		.12	.65	.63	1.30	1.26	1.46	1.42	1.24	1.10	1.18	1.18	13,64
1A	1	3	16,5	16	33	32	37	36	34	30	30	8,10	
		.12	.65	.63	1.30	1.26	1.46	1.42	1.41	1.33	1.18	1.18	17,82
2	2	3	19,5	19	39	38	43	42	42	40,5	30	30	9,40
		.12	.77	0.75	1.54	1.50	1.69	1.65	1.65	1.59	1.18	1.18	20,68
3	3	3	21	20,75	42	41,5	46	45,5	50	48	30	30	11,20
		.12	.83	.82	1.65	1.64	1.81	1.80	1.96	1.88	1.18	1.18	24,64
4	4	3	24	23,75	48	47,5	52	51,5	60	57	30	30	13,70
		.12	.94	.94	1.89	1.87	2.05	2.03	2.36	2.24	1.18	1.18	30,14
5	5	3	32	31,25	64	62,5	68	66,5	71	70	30	30	17,10
		.12	1.26	1.23	2.52	2.46	2.68	2.62	2.79	2.75	1.18	1.18	37,62
6	6	3	36	35,25	72	70,5	76	74,5	88	86	30	30	21,30
		.12	1.42	1.39	2.83	2.78	2.99	2.94	3.46	3.38	1.18	1.18	46,86
7	7	5	51,5	51	103	102	107	106	122	118	30	30	42,10
		.20	2.03	2.01	4.06	4.02	4.21	4.17	4.81	4.65	1.18	1.18	92,62
8	8	5	64	63	128	126	132	130	148	144	30	30	44,00
		.20	2.52	2.48	5.04	4.96	5.20	5.12	5.83	5.67	1.18	1.18	96,80

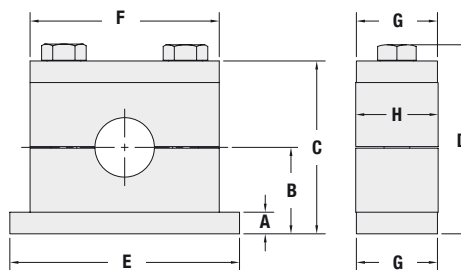

Heavy Series (DIN 3015, Part 2)

Group	STAUFF	DIN	Dimensions (mm/in)								Weight per 1 Pc.			
			A	B		C		D		F	PP/ PA/SA	AL	G	H
		Profiled Design		Type H (Smooth)		Profiled Design		Type H (Smooth)						
3S	1	8	24	23,25	48	46,5	54,4	52,9	74	55	56	30	30,5	0,32
		.31	.94	.92	1.89	1.83	2.14	2.09	2.91	2.16	2.20	1.18	1.20	.70
4S	2	8	32	31,25	64	62,5	70,4	68,9	86	70	70	30	30,5	0,40
		.31	1.26	1.23	2.52	2.46	2.77	2.72	3.39	2.76	2.76	1.18	1.20	.88
5S	3	8	38	37	76	74	82,4	80,4	100	85	85	30	30,5	0,49
		.31	1.50	1.46	2.99	2.91	3.24	3.17	3.94	3.35	3.35	1.18	1.20	1,08
6S	4	10	54,5	53,5	109	107	116,5	114,5	140	115	120	45	45	1,21
		.39	2.15	2.11	4.29	4.21	4.59	4.51	5.51	4.53	4.72	1.77	1.77	2,66
7S	5	10	70		140		150		180	154	152	60	60	2,30
		.39	2.76		5.51		5.91		7.09	6.06	5.98	2.36	2.36	5,06
8S	6	15	99		198		210,5		226	206	208	80	80	6,00
		.59	3.90		7.80		8.29		8.90	8.11	8.19	3.15	3.15	13,20
9S	7	15	115		230		245		270	251	255	90	91	8,70
		.59	4.53		9.06		9.65		10.63	9.88	10.04	3.54	3.58	19,14
10S	8	25	160		320		338,7		340	336	326	120	120	22,16
		.98	6.30		12.60		13.33		13.39	13.22	12.83	4.72	4.72	48,75
11S	9	30	235		470		488,7		520	470	470	160	162	54,11
		1.18	9.25		18.50		19.24		20.47	18.50	18.50	6.30	6.38	119,04
12S	10	30	295		590		608,7		680	630	630	180	182	77,40
		1.18	11.61		23.23		23.96		26.77	24.80	24.80	7.09	7.16	170,28

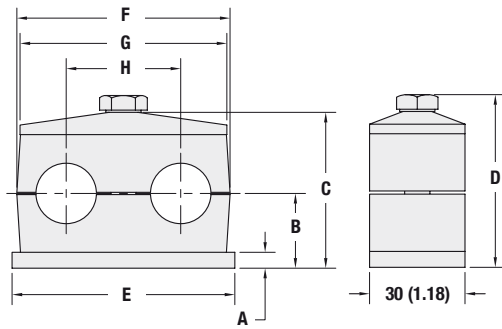
Dimensions & Weights of Clamp Assemblies

Twin Series (DIN 3015, Part 3)

Group	STAUFF	DIN	Dimensions (mm/in)								E	F	G	H	Weight per 100 Pcs. SP**/**PP-GD-AS** (kg/lbs)
			A	B		C		D							
				Profiled Design	Type H (Smooth)	Profiled Design	Type H (Smooth)	Profiled Design	Type H (Smooth)						
1D	1		3	16,5	16,25	37	36,5	41	40,5	37	36	34	20	7,60	
			.12	.65	.64	1.46	1.44	1.61	1.59	1.46	1.42	1.34	.79	16.72	
2D	2		5	18,5	18,25	39	38,5	44	43,5	55	53	52	29	13,50	
			.20	.73	.72	1.54	1.52	1.73	1.71	2.17	2.09	2.05	1.14	29.70	
3D	3		5	23,5	23,25	49	48,5	54	53,5	70	67	65	36	17,70	
			.20	.93	.92	1.93	1.91	2.13	2.11	2.76	2.64	2.56	1.42	38.94	
4D	4		5	25	24	52	50	57	55	85	80	79	45	20,40	
			.20	.98	.94	2.05	1.97	2.24	2.17	3.35	3.15	3.11	1.77	44.88	
5D	5		5	31,5	31	65	64	70	69	110	106	102	56	27,70	
			.20	1.24	1.22	2.56	2.52	2.76	2.72	4.33	4.17	4.02	2.20	60.94	

Packaging Units (Selection)
Standard Series (DIN 3015, Part 1)
Heavy Series (DIN 3015, Part 2)
Twin Series (DIN 3015, Part 3)
Clamp Bodies (Polypropylene / Polyamide)

Group	STAUFF	DIN	Quantity per Bag (in Pcs.)
1 - 6	0 - 6		25
7 + 8	7 + 8		10

Clamp Bodies (Polypropylene / Polyamide)

Group	STAUFF	DIN	Quantity per Bag (in Pcs.)
3S - 6S	1 - 4		20
7S	5		10
8S - 12S	6 - 10		1

Clamp Bodies (Polypropylene / Polyamide)

Group	STAUFF	DIN	Quantity per Bag (in Pcs.)
1D - 4D	1 - 4		25
5D	5		10

Clamp Bodies (Aluminium)

Group	STAUFF	DIN	Quantity per Bag (in Pcs.)
1 - 5	0 - 5		25
6	6		10

Clamp Bodies (Aluminium)

Group	STAUFF	DIN	Quantity per Bag (in Pcs.)
3S - 7S	1 - 5		10
8S - 12S	6 - 10		1

**Weld Plates (Type SPAL)
Cover Plates (Type DPAL)**

Group	STAUFF	DIN	Quantity per Bag (in Pcs.)
1D - 4D	1 - 4		25
5D	5		10

**Weld Plates (Type SP)
Cover Plates (Type DP)**

Group	STAUFF	DIN	Quantity per Bag (in Pcs.)
1 - 6	0 - 6		25
7 + 8	7 + 8		10

**Weld Plates (Type SPAL)
Cover Plates (Type DPAL)**

Group	STAUFF	DIN	Quantity per Bag (in Pcs.)
3S - 6S	1 - 4		20
7S	5		10
8S - 12S	6 - 10		1

**Hexagon Rail Nut (Type SM)
Channel Rail Adaptor (Type CRA)**

Group	STAUFF	DIN	Quantity per Bag (in Pcs.)
1D	1		50
2D - 5D	2 - 5		25

**Hexagon Rail Nut (Type SM)
Channel Rail Adaptor (Type CRA)**

Group	STAUFF	DIN	Quantity per Bag (in Pcs.)
1 - 8	0 - 8		50

**Mounting Rail Nut (Type GMV)
Channel Rail Adaptor (Type CRA)**

Group	STAUFF	DIN	Quantity per Bag (in Pcs.)
3S - 6S	1 - 4		40

Consult STAUFF and ask for standard packaging units for further components or special packaging options.

