

# Multi-line and Progressive Systems

Product Catalogue



Productivity is key in today's global economy. Proper lubrication increases uptime and makes maintenance routines simple.



# Multi-line and Progressive Systems



## Our Experience

Lincoln was established in 1910 and is the long-standing world leader in grease lubrication systems and equipment. Decades of business experience have provided us with a high level of expertise and know-how within the lubrication system industry. As a pioneer in the industry, we will continue being a trend-setter confidently providing our customers with the best lubrication system solutions in both price and quality.

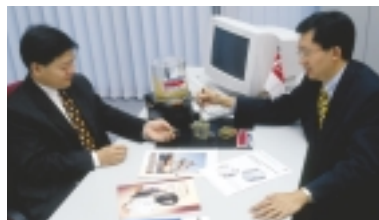

## Our Service

Our customer service includes the consulting, engineering and planning of customer-oriented systems for all applications, the manufacturing of standard components such as pumps, metering devices or control equipment, the installation and start up of lubrication systems on site in all parts of the world, as well as the customer training, and after-market service.

## Our Quality

Our certified Quality Management System according to DIN EN ISO 9001, our expertise, consulting qualities and inventiveness, lead the way for future customer-oriented, economical and intelligent solutions.



## Our Product

Lincoln lubrication systems reduce friction and wear; thereby, decreasing maintenance costs, improving productivity, ensuring a higher level of safety and contribution to the environment.

## Our Environmental Management System

Our Environmental Management System according to DIN EN ISO 14001 and EMAS, is an integral part of our company philosophy that reflects Lincoln's future orientation.

## Our Motto

Keep in motion –  
Bleiben Sie mit uns in Bewegung!

# Multi-line and Progressive Systems



## Application

### Pure Multi-line Systems

- Dispersed, single lubrication points
- Large quantities of lubricant per lube point
- Individual adjustment for each lube point
- Continuous supply requirement

### Pure Progressive Systems

- Several lubrication points within small to medium distances
- Ideal for machines and small systems

### Sample Applications

Small to medium sized systems and machines.

### Industries

General industry, construction machines, mobile applications

Multi-line and progressive systems constantly operate as long as lubricant is fed by the pump.

For systems that have more than 1 lubrication point within a relatively short distance, a pure multi-line system is not always economical. Additionally, pure Multi-line systems are not easily monitored. As a result, progressive systems or combined progressive/multi-line systems often provide the best solution.

The high-precision SSV progressive metering device divides the lubricant input into desired quantities.

## Capabilities

### Capabilities of Progressive or Combined Progressive/Multi-line Systems:

- Visual or electric monitoring of the entire system via metering device
- Reliable lubrication even under severe conditions
- Easily extendible via available pump element
- Capable of completely supplying machines or small systems with lubricant.

## Function

The system will continue to operate as long as the pump is in operation. When the pump is turned off, the progressive metering device will stop in its current position. Upon restarting, the progressive metering device will carry on where it left off.

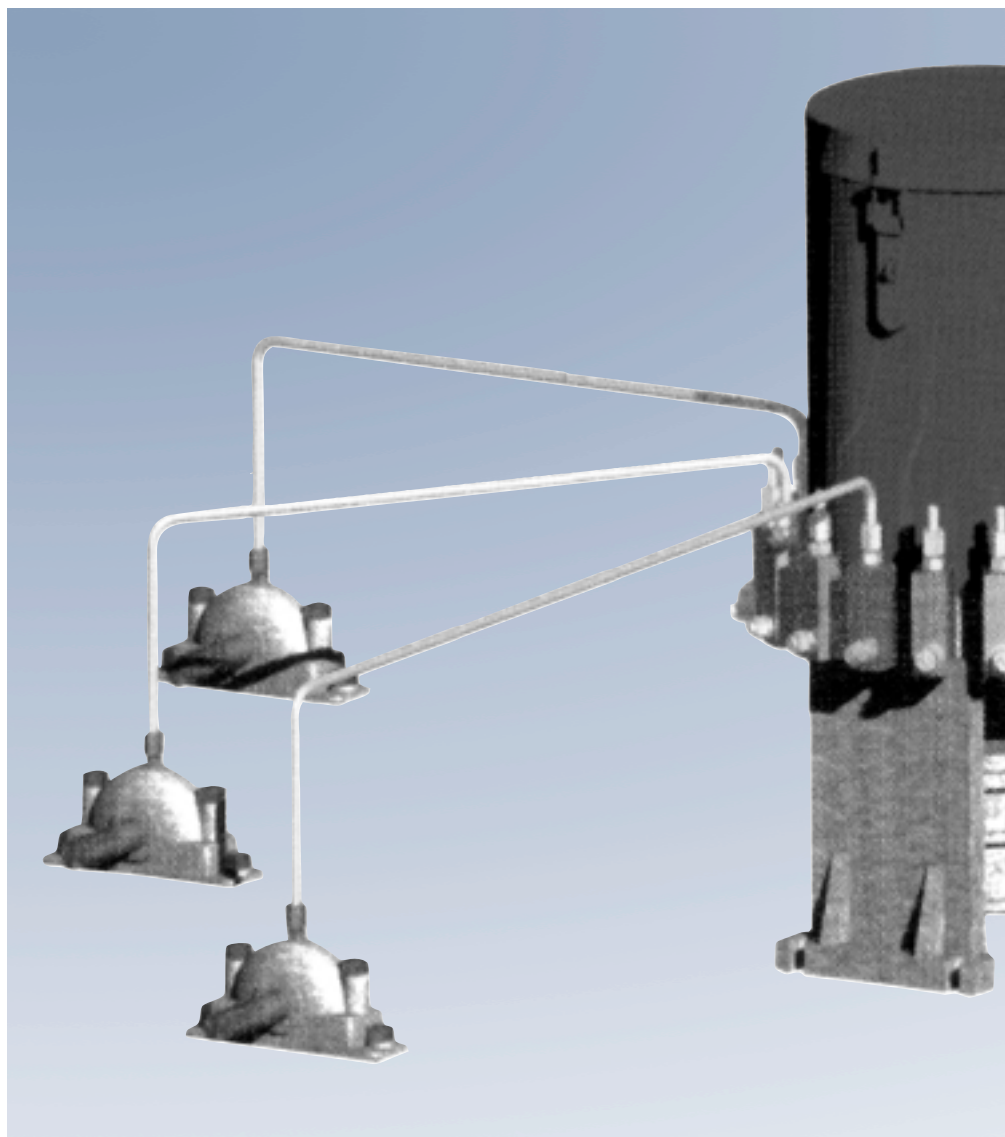

*Schematic Combined Multi-line / Progressive System*

**Common Components:**

**Pumps:**

HJ\*, HP, HPG/HPGO,  
HP-500W manual pumps,  
QLS301, 203, 233, 205, 215,  
ZPU01/02\* electric pumps,  
PPG/PPGO  
pneumatic pumps,  
FlowMaster hydraulic pumps\*\*  
HT1L101

**Metering Devices:**

SSV, SSVM, SSV-FL

\* See Two-line section

\*\* Not covered in this catalogue -  
ask your Lincoln representative  
for details

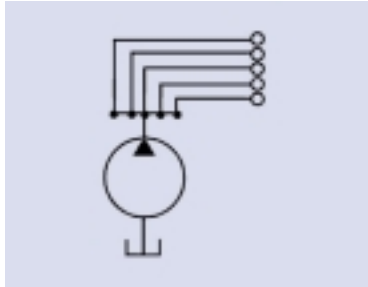

*Schematic Multi-line System*

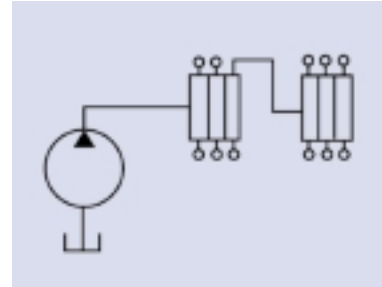

*Schematic Progressive System*

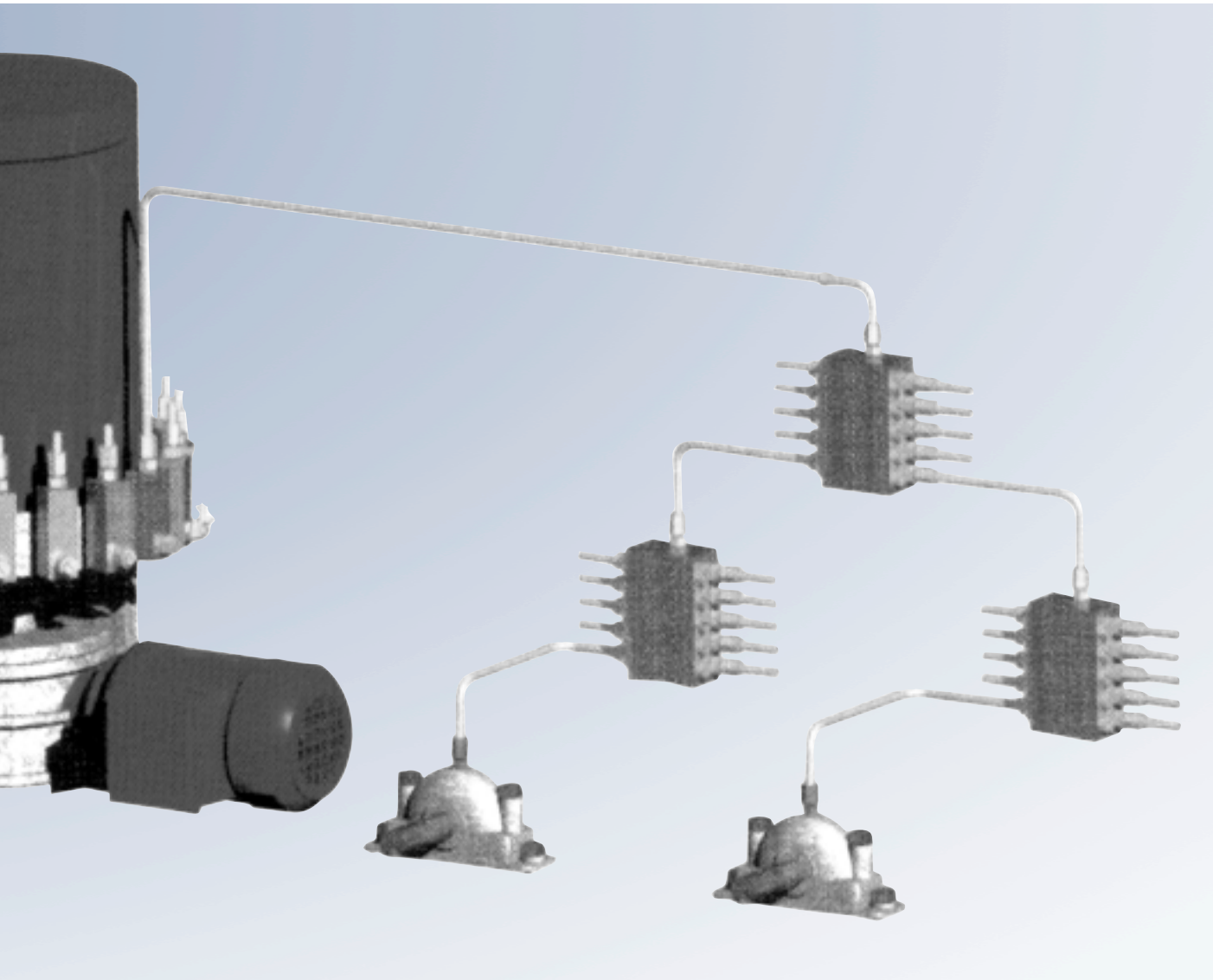

# HP, HPG, HPO, HPGO Pumps

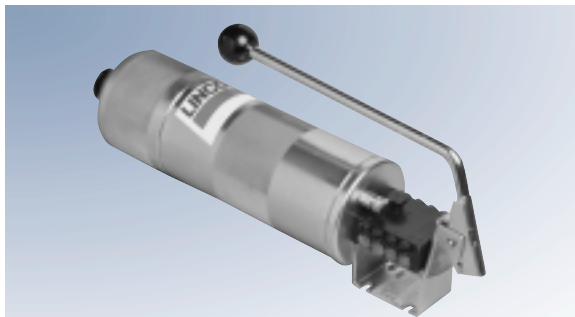

These economically priced hand-operated single-stroke pumps deliver an accurately metered amount of lubricant, either grease or oil, depending on the version. The grease versions, HP and HPG, are equipped with a spring-loaded follower plate and a control rod for lubricant control. The oil version comes with a clear plastic reservoir for visual level control. When used in conjunction with SSV divider blocks they can supply grease to 1 to 64 lubrication points.

HPG15

Part No.	Description	Reservoir Capacity			Number of Outlets	Level Indicator
		Liters	In <sup>3</sup>	Lbs.		
604-25103-1	HP15	1.5	91.5	3	1	indicator rod
604-25109-2	HPG15	1.5	91.5	3	2 – 8	indicator rod
604-27162-1	HPO18 (oil)	1.8	109.8	3.6	1	transparent

## Technical Data

	HP	HPG
lubricant output per stroke	1.6 cm <sup>3</sup> (0.097 in <sup>3</sup> )	
lubricant output per outlet metering device	0.2 cm <sup>3</sup> (0.012 in <sup>3</sup> )	
maximum operating pressure	250 bar (3626 psi)	
outlet ports	R1/8 female (BSPT) suitable for 4 and 6 mm tube*	
follower	spring loaded	

\* see SSV metering devices for outlet fittings

## Dimensions

Model	Height	Width*	Depth
HP15	460 mm (18.1 in)	190 mm (7.5 in)	112 mm (4.4 in)
HPG15	635 mm (24.6 in) level indicator fully extended	190 mm (7.5 in)	112 mm (4.4 in)
HPO18	420 mm (16.5 in)	190 mm (7.5 in)	112 mm (4.4 in)

\* 335 mm (13.2 in) handle extended

# HP500 and HP500-SSV Pumps

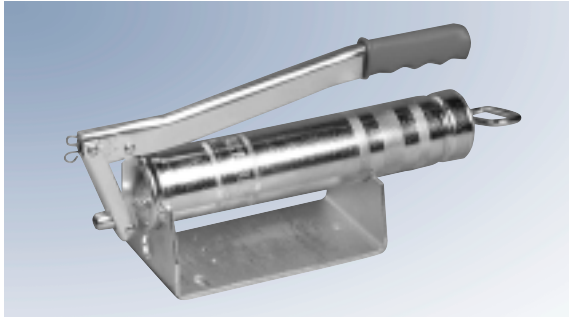

HP500W

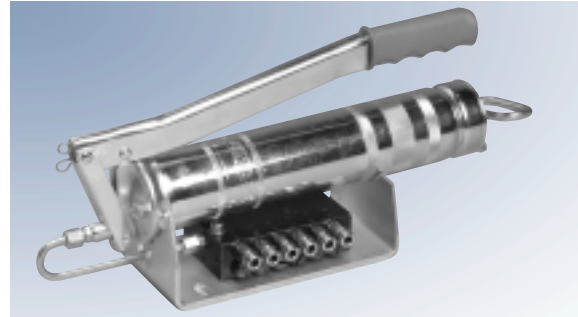

HP500W-SSV

The manual pumps HP500W and HP500W-SSV offer a special low-cost possibility of equipping a machine with a manual central lubrication pump.

The pumps are used where no automatic or continuous lubricant supply is required, but where a simple lubrication process by a central lubrication pump is desired.

The filling of the grease reservoir can be performed by means of a standard 400 g cartridge, or directly from a grease barrel or with a filling pump.

Part No.	Description	Reservoir Capacity			Number of Outlets
		Liters	In <sup>3</sup>	Lbs.	
244-14164-1	HP500W	0.5	30	1	1
604-28766-1	HP500W-SSV6	0.5	30	1	2 – 6
604-28767-1	HP500W-SSV8	0.5	30	1	2 – 8
604-28768-1	HP500W-SSV10	0.5	30	1	2 – 10
604-28769-1	HP500W-SSV12	0.5	30	1	2 – 12

## Technical Data

	HP500W	HP500W-SSV
lubricant output per stroke	1.5 cm <sup>3</sup> (0.091 in <sup>3</sup> )	
lubricant output per metering device outlet	0.2 cm <sup>3</sup> (0.012 in <sup>3</sup> )	
outlet thread connection	M10 x 1 female	R1/8 female (BSPT)*
maximum operating pressure	400 bar (5800 psi)	350 bar (5076 psi)
suitable lubricants	NGLI 2 grease	

\* see SSV metering devices for outlet fittings

# PP, PPO, PPG, PPGO Pumps

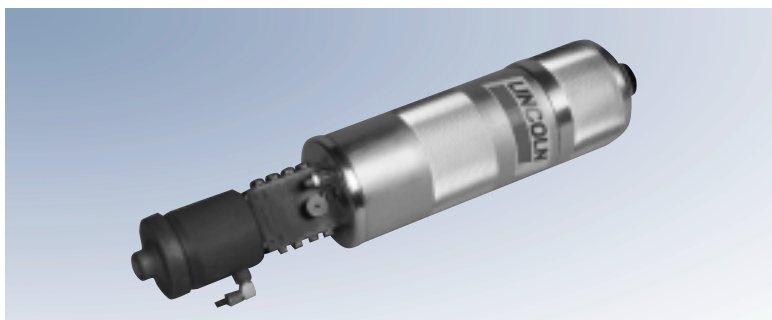

PPG15-K

The pump model series PP is for progressive systems. The pump is a pneumatically operated single-stroke pump requiring a 3/2 way air-valve for activating the air cylinder. Depending on the pump version it can be used for oil (PPGO) or grease (PP and PPG)

supply. The version for grease systems is equipped with a spring-loaded follower plate and a control rod for lubricant control. The oil version comes with a clearplastic reservoir to enable visual level control.



PPGO18

## Popular Models

Part No.	Description	Reservoir Capacity	Grease or Oil	Number of Outlets	Output per Stroke
604-25105-2	PP15	1.5 liters (91 in <sup>3</sup> )	grease	1	2.6 cm <sup>3</sup> (0.158 in <sup>3</sup> )
604-25111-3	PPG15	1.5 liters (91 in <sup>3</sup> )	grease	8	2.6 cm <sup>3</sup> (0.158 in <sup>3</sup> )
604-25129-2	PPG4-K	0.4 liters (24 in <sup>3</sup> )	grease	8	0.2 cm <sup>3</sup> per outlet
604-25130-3	PPG15-K	1.5 liters (91 in <sup>3</sup> )	grease	8	(0.012 in <sup>3</sup> )
604-27223-1	PPO18	1.8 liters (110 in <sup>3</sup> )	oil	1	2.6 cm <sup>3</sup> (0.158 in <sup>3</sup> )
604-27213-1	PPGO18	1.8 liters (110 in <sup>3</sup> )	oil	8	2.6 cm <sup>3</sup> (0.158 in <sup>3</sup> ) 0.2 cm <sup>3</sup> per outlet (0.012 in <sup>3</sup> )

## Technical Data

	PP	PPG	PPO	PPGO
pump pressure ratio	40:1			
air pressure	min. 4 bar (58 psi) / max. 10 bar (145 psi)			
maximum operating pressure	300 bar (4350 psi)	250 bar (3625 psi)	300 bar (4350 psi)	250 bar (3625 psi)
lube outlet	6 mm	for 4 or 6 mm tube*	6 mm	for 4 or 6 mm tube*
air inlet	G 1/8 female (BSPP)			

\* see SSV metering device for outlet fittings

## Dimensions

Model	Height	Width	Depth
PP 15	550 mm (22 in)	115 mm (4.6 in)	122 mm (4.8 in)
PPG 15	725 mm (29 in) level indicator fully extended	115 mm (4.6 in)	122 mm (4.8 in)
PPG 15-K			
PPO 18	473 mm (16.6 in)	115 mm (4.6 in)	122 mm (4.8 in)
PPGO 18			

The QLS 301, 311 or 321 is a complete monitored lubrication system with low-level control for a maximum of 18 lubrication points. The 321 is specifically for trailers and semi-trailers. The QLS family includes pumps available with or without mounted SSV valves and are made for the standard high-pressure plastic tubing  $\varnothing$  6 x 1.5. The 1 liter reservoir pumps are available in 12 or 24 VDC and 120 and 230 VAC (not available on the 321 pumps). Refer to the pump identification codes for a complete listing of available pump configurations.



QLS301

## Popular 301 Models for Grease Lubrication

Model No.	Valve Type	Valve Mount	Voltage	Cable
P30131211151	SSV6	back	12 DC	10 m (30 ft)
P30131411151	SSV6	back	24 DC	10 m (30 ft)
P30142611111	SSV8	bottom	120 AC	none
P30142811111	SSV8	bottom	230 AC	none
P30161211151	SSV12	back	12 DC	10 m (30 ft)
P30161411151	SSV12	back	24 DC	10 m (30 ft)
P30162611111	SSV12	bottom	120 AC	none
P30162811111	SSV12	bottom	230 AC	none
P30191211151	SSV18	back	12 DC	10 m (30 ft)
P30191411151	SSV18	back	24 DC	10 m (30 ft)
P30192611111	SSV18	bottom	120 AC	none
P30192811111	SSV18	bottom	230 AC	none

## Popular 311 Models for Oil Lubrication

Model No.	Valve Type	Valve Mount	Voltage	Cable
P31131211151	SSV6	back	12 DC	10 m (30 ft)
P31131411151	SSV6	back	24 DC	10 m (30 ft)
P31142611111	SSV8	bottom	120 AC	none
P31142811111	SSV8	bottom	230 AC	none
P31161211151	SSV12	back	12 DC	10 m (30 ft)
P31161411151	SSV12	back	24 DC	10 m (30 ft)
P31162611111	SSV12	bottom	120 AC	none
P31162811111	SSV12	bottom	230 AC	none
P31191211151	SSV18	back	12 DC	10 m (30 ft)
P31191411151	SSV18	back	24 DC	10 m (30 ft)
P31192611111	SSV18	bottom	120 AC	none
P31192811111	SSV18	bottom	230 AC	none





QLS301, QLS311 with Remote Control

## Popular 301/311 Models for Remote Control

Model No.	Valve Type	Valve Mount	Voltage	Lubricant
P30131411110	SSV6	back	24 VDC	grease
P30161411110	SSV12	back	24 VDC	grease
P30191411110	SSV18	back	24 VDC	grease
P31131411110	SSV6	back	24 VDC	oil
P31161411110	SSV12	back	24 VDC	oil
P31191411110	SSV18	back	24 VDC	oil
650-40768-3	SSV8	bottom	120 VAC	grease
650-40768-4	SSV12	bottom	120 VAC	grease
650-40768-5	SSV18	bottom	120 VAC	grease
650-40765-4	SSV8	bottom	120 VAC	oil
650-40765-5	SSV12	bottom	120 VAC	oil
650-40765-6	SSV18	bottom	120 VAC	oil



QLS321

## Popular 321 Models for Grease Lubrication of Trailers

Model No.	Valve Type	Valve Mount	Voltage	Cable
P32131210531	SSV6	bottom	12 DC	6 m (19 ft)
P32131410531	SSV6	bottom	24 DC	6 m (19 ft)
P32161210531	SSV12	bottom	12 DC	6 m (19 ft)
P32161410531	SSV12	bottom	24 DC	6 m (19 ft)
P32191210531	SSV18	bottom	12 DC	6 m (19 ft)
P32191410531	SSV18	bottom	24 DC	6 m (19 ft)

## QLS Technical Data

operating pressure	
QLS301 / 321	205 bar (3000 psi)
QLS311	80 bar (1160 psi)
reservoir	1 liter - clear plastic / (61 in <sup>3</sup> ) / 2 Lbs. with low-level control
output per outlet & cycle	approx. 0.2 cm <sup>3</sup> / 0.012 in <sup>3</sup>
operating voltage	24 and 12 VDC / 120 and 230 VCA, 50 / 60 Hz (not for QLS321)
operating current	12 VDC / 2.0 A, 24 VDC / 1.0 A, 120 VAC / 1.0 A, 230 VAC / 0.5 A
operating temperature	-25 to 70° C / -13 to 158° F
lubricants	
QLS301 / 321	grease up to NLGI 2
QLS311	oil
class of protection	NEMA 4
number of outlets	1, 6, 8, 12 or 18 (depending on version)
number of cycles or run time	
QLS301 / 311	1 cycle (with 6 or 8 divider valve 1, 2 or 3 cycles are possible)
QLS321	1 to 32 minutes run time
remote control models	max. 4 minutes run time
lubrication pause time	
QLS301 / 311	20 minutes to 100 hours
QLS321	1 hour to 16 hours
remote control models	min. 4 minutes
timer memory	indefinite

## Accessories for all QLS Series Pumps

Part No.	Description	Kit Size	Lube Fittings Included
550-36791-1	SSV6/8	inch size kit	yes
550-36971-2	SSV12	inch size kit	yes
550-36971-3	SSV18	inch size kit	yes
550-36970-1	SSV6/8	metric size kit	no
550-36970-2	SSV12	metric size kit	no
550-36970-3	SSV18	metric size kit	no

# QLS 301 Identification Code



## Pump Models Examples for Part Numbers

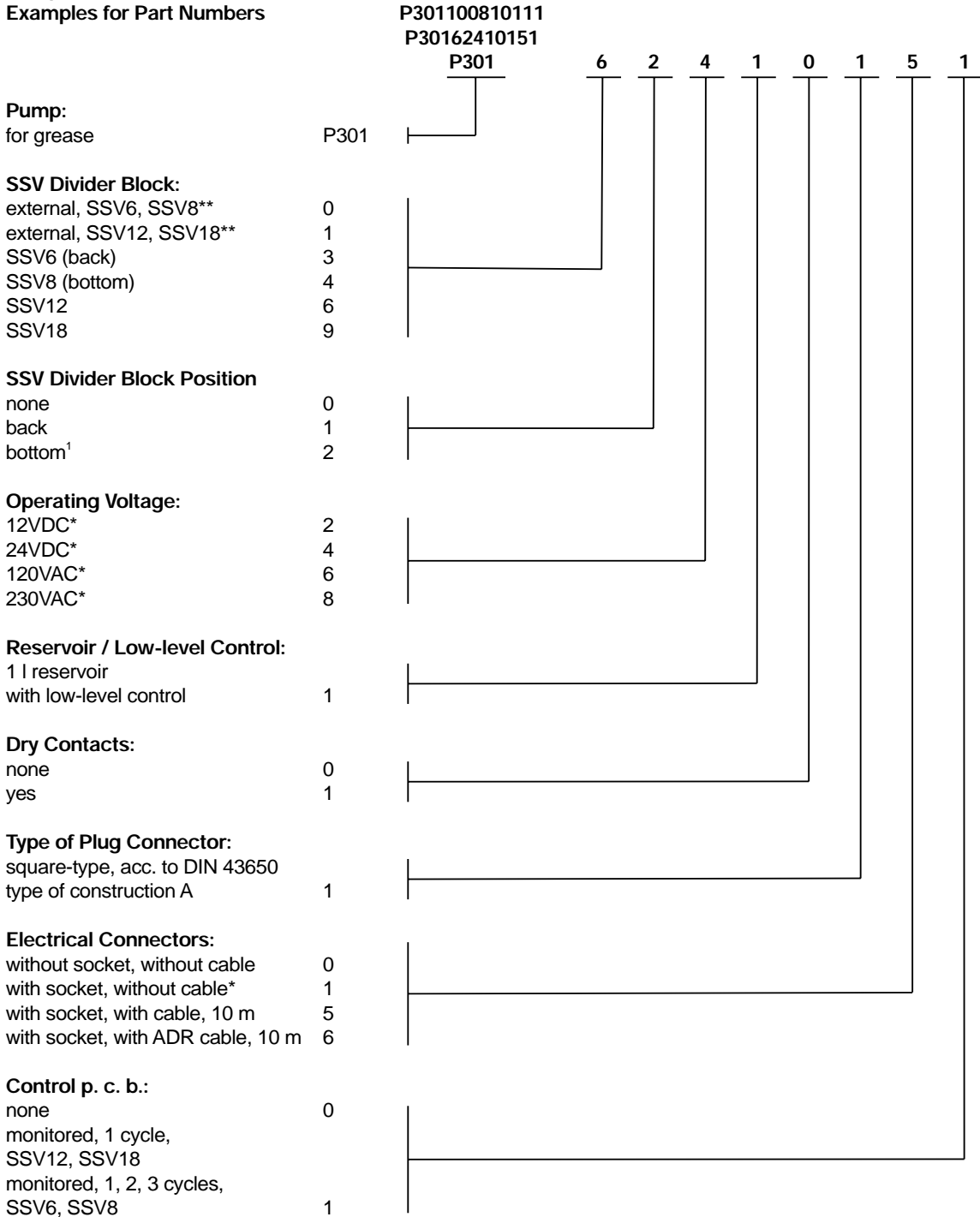

### Examples of an explained model number: Pump model P30131810111 –

Grease pump, SSV6 block mounted on the back, 230 VAC, with low-level and without dry contact.

\* Note: Standard 120 and 230 VAC pump models for industry are shipped without electrical cable. Standard 12 and 24 VDC pump models for mobil applications can be shipped with 10 meter (30") electrical cable.

\*\* Note: For external divider block application only use the specific divider blocks SSV ... KNQLS.

On pump models without divider block it is not possible to close cycles without changes on the p. c. b..

<sup>1</sup> Note: Do not use QLS 301 with SSV block in bottom mounting position for mobile applications. Don't install the pump in areas exposed to shock.

### Accessory Kits:

#### Inch Size Kits

SSV6/8 Part No.550-36971-1

SSV12 Part No.550-36971-2

SSV18 Part No.550-36971-3

#### Metric Size Kits

SSV6/8 Part No.550-36970-1\*\*\*

SSV12 Part No.550-36972-2\*\*\*

SSV6/8 Part No.550-36973-2\*\*\*

\*\*\* Lube fittings must be ordered separately



Pump 203

The 203 centralized lubrication pump is a powerful and robust compact multi-line pump that can drive up to 3 elements and is used in progressive (Quicklub or Modular Lube) automated lubrication systems. It is perfect for mobile applications, small and medium sized machinery and general industries. Versatile, compact and economical, this pump can be enhanced with low-level control and printed circuit board that allow for controlling the lubrication cycles.

The family of 203 pumps includes 12 and 24 VDC and VAC pumps that automatically adjust to supply voltages from 110 – 240 VAC. They are available with 1, 2 or 3 elements in 5, 6 or 7 mm or with an adjustable output element. Reservoir sizes are 2, 4 or 8 liters. Refer to the pump identification code for a complete listing of available pump configurations.

## Popular 203 Models

Part No.	Model	Power	Reservoir Capacity			Grease or Oil	Low-Level Control	Printed Circuit Board
			Liters	In <sup>3</sup>	Lbs.			
94012	P203-2XN-1K6-12-1A1.50-V20-A+SV	12 VDC	2	122	4	grease	no	yes
94024	P203-2XN-1K6-24-1A1.50-V20-A+SV	24 VDC	2	122	4	grease	no	yes
94212	P203-2XN-1K6-12-1A1.51-A+SV	12 VDC	2	122	4	grease	no	yes
94224	P203-2XN-1K6-24-1A1.51-A+SV	24 VDC	2	122	4	grease	no	no
94412	P203-4XNBO-1K6-12-1A1.50-V20-A+SV	12 VDC	4	244	8	grease	no	yes
94424	P203-4XNBO-1K6-24-1A1.50-V20-A+SV	24 VDC	4	244	8	grease	no	yes
94812	P203-8XNBO-1K6-12-1A1.50-V20-A+SV	12 VDC	8	488	16	grease	no	yes
94824	P203-8XNBO-1K6-24-1A1.50-V20-A+SV	24 VDC	8	488	16	grease	no	yes
94222	P203-2XL-1K6-24-2A4.12-MOD-A-SV	24 VDC	8	488	16	grease	no	yes
94422	P203-4XLBO-1K6-24-2A4.12-MOD-A+SV	24 VDC	8	488	16	grease	no	yes
94822	P203-8XLBO-1K6-24-2A4.12-MOD-A+SV	24 VDC	8	488	16	grease	no	yes
644-37426-1	*P203-2XN-1K6-24-2A1.10-V10	24 VDC	2	122	4	grease	no	yes
644-40716-2	*P203-2XNBO-1K6-AC-1A1.01-V10	AC	2	122	4	grease	no	yes
644-40717-5	*P203-2XNBO-1K6-AC-1A1.01	AC	2	122	4	grease	no	no
644-40583-3	*P203-2YLBO-1K6-24-1A1.01	24 VDC	2	122	4	oil	yes	no
644-40718-7	*P203-4XNBO-1K6-AC-1A1.01	AC	4	244	8	grease	no	no
644-40719-5	*P203-4XNBO-1K6-AC-1A1.01-V10	AC	4	244	8	grease	no	yes
644-40719-6	*P203-4YLBO-1K6-AC-1A1.01-V10	AC	4	244	8	oil	yes	yes
644-40718-1	*P203-4XLBO-1K6-AC-2A1.01	AC	4	244	8	grease	yes	no
644-40718-8	*P203-4YLBO-1K6-AC-1A1.01	AC	4	244	8	oil	yes	no
644-40718-5	*P203-4XLBO-1K7-AC-2A1.01	AC	4	244	8	grease	yes	no
644-40721-5	*P203-8XLBO-1K6-AC-2A1.01	AC	8	488	16	grease	yes	no
644-40762-2	*P203-8XLBO-1K6-AC-2A1.01-V10	AC	8	488	16	grease	yes	yes
644-40645-2	*P203-8YLBO-1K6-24-1A1.10	24 VDC	8	488	16	oil	yes	no
644-40550-4	*P203-8XLBO-1K7-24-2A1.01	24 VDC	8	488	16	grease	yes	no
644-40645-3	*P203-8XLBO-1K7-24-2A1.10	24 VDC	8	488	16	grease	yes	no

\*These pumps do not include a pressure relief valve which must be ordered separately.

## Dimensions

Size of Reservoir	Height	Width	Depth
2 l, standard	367 mm (14.4 in)	205 mm (8.1 in)	224 mm (8.8 in)
2 l, filling from top	403 mm (15.8 in)	205 mm (8.1 in)	224 mm (8.8 in)
2 l, flat	287 mm (11.3 in)	232 mm (9.1 in)	250 mm (9.8 in)
4 l	395 mm (15.6 in)	232 mm (9.1 in)	250 mm (9.8 in)
8 l	495 mm (19.5 in)	232 mm (9.1 in)	250 mm (9.8 in)

## Accessoires

Part No.	Description
600-26875-2	pump element with assy. piston ø 5 mm (K5)
600-26876-2	pump element with assy. piston ø 6 mm (K6)
600-26877-2	pump element with assy. piston ø 7 mm (K7)
600-28750-1	pump element with assy. piston for chisel paste (C7)
600-26178-1	adjustable pump element (KR)
624-28894-1	pressure relief valve SVTE-350-1/4 for 6 mm tube, 350 bar (5076 psi)
624-28892-1	pressure relief valve SVTE-270-1/4 for 6 mm tube, 270 bar (3916 psi)
624-28859-1	pressure relief valve SVTSV-270-1/4 with grease fitting for manual servicing, 1/8" NPT female supply line connection, 270 bar (3916 psi)
624-28891-1	pressure relief valve SVTE-200-1/4, for 6 mm tube, 200 bar (2900 psi)
624-28931-1	pressure relief valve with return to reservoir SVTSV-350-1/4 for 6 mm tube, 350 bar (5076 psi)
226-14105-5	required extension for pressure relief valve for 2 l flat, 4 l and 8 l reservoirs
244-14161-1	quick fill pump (no connecting parts)
638-37549-1	quick fill pump with straight connection fitting for 2 l reservoir
638-37548-1	quick fill pump with 90° connection fitting for 2 l reservoir
638-37561-1	quick fill pump with 90° connection fitting for 2 l flat, 4 l and 8 l reservoirs
233-13124-8	protective plug for quick fill pumps
233-13090-9	protective cap for quick fill pump
638-37549-2	quick fill pump and straight adapter for 4 l and 8 l reservoirs
538-36763-5	straight adapter for quick fill pump for 4 l and 8 l reservoirs
538-36763-4	90° adapter for quick fill pump for 4 l and 8 l reservoirs

## Technical Data

operating pressure	350 bar (5076 psi)				
reservoir	2, 4, 8 liters - clear plastic / (122, 244, 488 in <sup>3</sup> ) / 4, 8, 16 Lbs.				
output per element / min.	K5 mm	K6 mm	K7 mm	C7 mm (for chisel paste)	KR (adjustable)
	approx. 2 cm <sup>3</sup> /min (0.122 in <sup>3</sup> )	approx. 2.8 cm <sup>3</sup> /min (0.17 in <sup>3</sup> )	approx. 4 cm <sup>3</sup> /min (0.244 in <sup>3</sup> )	approx. 4 cm <sup>3</sup> /min (0.244 in <sup>3</sup> )	approx. 0.7 to 3 cm <sup>3</sup> /min (0.043 to 0.183 in <sup>3</sup> )
operating voltage	24 and 12 VDC / 95 to 265 VAC				
operating temperature	-25 to 75° C / -13 to 167° F				
lubricants	up to NGLI 2 / oil of at least 40 mm <sup>2</sup> /s				
class of protection	IP6K 9K acc. to DIN 40050 T9				
number of outlets	1, 2 or 3				
outlet thread	G 1/4 female (BSPP)				

# Identification Code Pump Models 203



## Examples for Model Designation

P203-	2	X	N	-	1	K6-	24-	1A	1.	10-	V10
P203-	4	X	LBO	-	1	K6-	24-	2A	1.	10-	V10
P203-	2	X	N	-	1	K6-	AC-	1A	1.	01-	V10
P203-	2	X	N	-	1	K6-	AC-	1A	1.	01	
P203-	8	Y	NBO	-	2	K7-	24-	2A	4.	12-	M00
P203-	2	X	NFL	-	1	K5-	12-	1A	1.	10-	H

## Basic Pump Model for Grease or Oil:

with 1-3 outlets and 12 VDC  
or 24 VDC motor

### Reservoir Design:

2 = 2 l transparent plastic reservoir  
4 = 4 l transparent plastic reservoir  
8 = 8 l transparent plastic reservoir

X = reservoir for grease  
Y = reservoir for oil

N = standard design  
L = low-level control

### Without

designation = standard reservoir (2 liters)  
BO = filling from top  
FL = flat-type reservoir (2 liters)

### Pump Elements:

1-3 = number of the use elements

K5 = piston diameter = 5 mm  
K6 = piston diameter = 6 mm  
K7 = piston diameter = 7 mm  
KR = pump element adjustable,  
= piston diameter = 7 mm  
C7 = piston diameter = 7 mm\*\*\*

### Operating Voltage:

12VDC or 24VDC motor  
AC = 94 - 265 VAC (47 - 63) with 24 VDC motor

### Number of the Possible Connections:

1A = 1 connection, supply voltage  
2A = 2 connections, supply voltage +  
remote control for additional lubrication,  
for low-level control\*\*\*, piston detector (microprocessor)

### Type of Connection:

1 = square type plug acc. to DIN 43650, type of connection A  
4 = AMP - flanged plug (microprocessor)  
8 = PG - cable gland  
9 = AMP - plug, wire to wire

### Connection Outside the Pump:

00 = without socket-outlet, without cable  
01 = with socket-outlet, without cable  
10 = with 10 m cable  
11 = with 10 m ADR cable  
12 = with 10 m cable, 4 - wire (microprocessor M00 - M07)  
13 = with 10 m cable, 5 - wire (microprocessor M08 - M23)

### Control P.C.B. 12 V / 24 V:

V10 - V13 with adjustable pause and operating time (V20 - V23 for USA)  
V10 - V13 ADR with adjustable pause and operating time  
M 00 ...M 23\* with microprocessor control  
(various adjustments – see combinations of the jumper positions)  
H-for trailer or semitrailors; H,- for ADR for trailers and semitrailors\*  
no designation: pump without control p. c. b.

\* Not in conjunction with Hirschman plugs (type of connection 1)

\*\* For transport of hazard materials

\*\*\* C7 Designation of pump elements (chise) for supplying of the chisel paste

\*\*\*\* Low-level control for oil; connection of low-level control won't be considered

Note: Any pump combinations other than the above standard pumps can be composed and ordered in accordance with the valid model identification code.

# 233 Pumps with Data Logger QuickData



The 233 centralized lubrication pump is a powerful and robust compact multi-line pump that can drive up to 3 elements and is used in progressive (Quicklub or Modular Lube) automated lubrication systems. The 233 is ideal for mobile applications, rental machines and construction machines. Versatile, compact and economical, this pump is enhanced with low-level control, printed circuit board MDF00 with attached data logger module and a keypad with display.

## QuickData Displays

- Current status and operating data
- Malfunctions of the lubrication system with the time of occurrence
- Remediating of the malfunction with date, time and duration of malfunction
- Low-level signal of reservoir and regular refilling
- Modifications in the pause time programming
- Number of automatically and manually triggered lube cycles as well as the corresponding lubricant consumption
- Power supply interruptions

All data can be read out by means of a laptop or p.d.a. via an integrated or separate IR interface. All indications enable the users to draw their conclusions regarding the condition, function, reliability, usability and duration of service of the machine or the device. All information can be analyzed and documented and is then available as a written protocol.



Pump233

The family of 233 pumps includes 12 and 24 VDC pumps. They are available with 1, 2 or 3 elements in 5, 6 or 7 mm or with an adjustable output element. Reservoir sizes are 2, 4 or 8 liters. Refer to the pump identification code for a complete listing of available pump configurations.

## Models

Part No.	Model	Power	Reservoir Capacity			Grease	Low-Level Control	Printed Circuit Board
			Liters	In <sup>3</sup>	Lbs.			
644-40824-1	P233-2XL-1K6-24-2A5.10-MDF00	24 VDC	2	122	4	grease	yes	yes
644-40824-2	P233-2XLBO-1K6-24-2A5.10-MDF00	24 VDC	2	122	4	grease	yes	yes
644-40826-1	P233-4XLBO-1K6-24-2A5.10-MDF00	24 VDC	4	244	8	grease	yes	yes
644-40827-1	P233-8XLBO-1K6-24-2A5.10-MDF00	24 VDC	8	488	16	grease	yes	yes

*These pumps do not include a pressure relief valve which must be ordered separately.*

Other technical data and dimensions are identical to the P203.

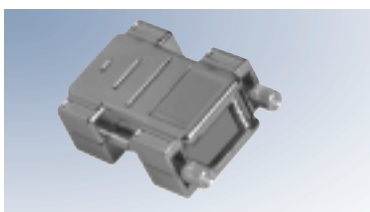

Infrared Interface

## Accessories

designation	part no.
infrared interface	236-10127-1
diagnostic software	810-55291-1
piston detector	234-13188-2





Pump205

The 205 centralized lubrication pump is a high pressure multi-line pump that can drive up to 5 elements and is used in progressive automated lubrication systems. It is capable of handling direct supply of lubrication points or as a central lubrication pump in larger progressive systems.

The design of the drive and eccentric shaft, the high efficiency worm gear, a minimal number of parts, and the multi-range motor, provide the 205 pump with several advantages. The 205 pumps are available with a three-phased flange mount and multi-range motor for 380-420 volts at 50 Hz or 440-480 volts at 60 Hz, or with a free shaft end for use with other motors. Various gear ratios and reservoir sizes, with or without level control are available. The reservoir, available in 4, 5 or 8 liter sizes, is suitable for both grease and oil.

## Popular 205 Models

Part No.	Description	Motor	Gear Ratio	Reservoir Size			Level Control	Number of Elements (Size)
				Liters	In <sup>3</sup>	Lbs.		
655-40655-9	P205-M280-4XYN-4K6-380/420-440/480	3-phase	280:1	4	244	8	no	4 (6 mm)
655-40654-2	P205-M070-5XYN-1K7-380-420/440-480	3-phase	70:1	5	305	10	no	1 (7 mm)
655-40655-3	P205-M280-5XYBU-1K6-380-420/440-480	3-phase	280:1	5	305	10	yes	1 (6 mm)
655-40673-2	P205-M070-8XYBU-1K6-380-420/440-480	3-phase	70:1	8	488	16	yes	1 (6 mm)
655-40704-2	P205-M070-5XYN-4K6-380-420/440-480	3-phase	70:1	5	305	10	no	4 (6 mm)

*These pumps do not include a pressure relief valve which must be ordered separately.*

## Accessories

Part No.	Description
624-28070-1	relief valve SVEVT-350-G 1/4" for 6 mm tube
624-28774-1	relief valve SVEVT-350-G 1/4" for 8 mm tube
304-17571-1	filling connection G 1/4" female* (BSPP)
304-17574-1	filling connection G 1/4" female* (BSPP)
600-26875-2	pump element with assy. piston ø 5 (K5)
600-26876-2	pump element with assy. piston ø 6 (K6)
600-26877-2	pump element with assy. piston ø 7 (K7)
600-26178-1	adjustable pump element (KR)

\* Filling connector is for vacant outlet ports.

## Technical Data

number of outlets	1 - 5			
threaded connection	G 1/4 female (BSPP)			
maximum operating pressure	350 bar (5076 psi)			
suitable lubricants	grease up to NGLI 2 NGLI 3 on request oil with viscosity of min. 20 mm <sup>2</sup> /s			
lubricant output per piston stroke	5 mm 0.11 cm <sup>3</sup> (0.0068 in <sup>3</sup> )	6mm 0.16 cm <sup>3</sup> (0.0098 in <sup>3</sup> )	7 mm 0.23 cm <sup>3</sup> (0.014 in <sup>3</sup> )	Adjustable 0.04 - .18 cm <sup>3</sup> (0.002 to 0.011 in <sup>3</sup> /min)
lubricant output per hour (output increases by 20% for 60 Hz applications)	ratio	70:1	280:1	700:1
	piston dia. 5 mm	115 cm <sup>3</sup> (7.01 in <sup>3</sup> )	29 cm <sup>3</sup> (1.77 in <sup>3</sup> )	11 cm <sup>3</sup> (0.67 in <sup>3</sup> )
	piston dia. 6 mm	172 cm <sup>3</sup> (10.50 in <sup>3</sup> )	43 cm <sup>3</sup> (2.62 in <sup>3</sup> )	17 cm <sup>3</sup> (1.04 in <sup>3</sup> )
	Piston dia. 7 mm	253 cm <sup>3</sup> (15.44 in <sup>3</sup> )	63 cm <sup>3</sup> (3.84 in <sup>3</sup> )	25 cm <sup>3</sup> (1.52 in <sup>3</sup> )
	adjustable	46-200 cm <sup>3</sup> (2.8-12.2 in <sup>3</sup> )	11.5 – 52 cm <sup>3</sup> (0.70-3.17 in <sup>3</sup> )	5 – 22 cm <sup>3</sup> (0.31-1.34 in <sup>3</sup> )
operating temperature	-20 to 70° C (-4 to 158° F)			
level control	ultrasonic sensor for low and high-level control			

## Dimensions

Reservoir Size	Height	Width	Depth
8 liters (plastic) (with low-level control)	507 mm (20 in)	280 – 360 mm (11 – 14 in) depending on version	227 – 300 mm (9 – 12 in) depending on version
4 liters (plastic) (with low-level control)	406 mm (16 in)		
5 liters (metal) (with low-level control)	435 mm (17 in)		

# Identification Code Pump Models 205



The complete pump unit is defined by a type code on the nameplate.

Examples of Type Codes:	Description					
	P205-	M	070-	4XYN-	5 K6-	380-420 / 440-480
	P205-	M	070-	5XYN-	1 K7-	380-420 / 440-480
	P205-	F	280-	4XYBU-	1 K7-	
	P205-	M	700-	8XYBU-	2 KR-	360-420 / 440-480

### Basic Type (Housing Assembly):

P205 = housing assembly for all pump models

### Drive Assembly:

M = three-phase flanged motor  
the motor designation with extension e.g. for voltages, frequencies, explosion-proof design is added to the type code

F = free shaft end

280 = gear ratio  $i = 1 : 280$

700 = gear ratio  $i = 1 : 700$

070 = gear ratio  $i = 1 : 70$

### Reservoir Assembly:

4 = 4 l plastic reservoir

5 = 5 l sheet metal reservoir

8 = 8 l plastic reservoir

XY = reservoir for grease and oil

N = reservoir without level control

BU = reservoir with low and high-level control (ultrasonic sensor)

*Note: The ultrasonic sensor is equipped with 2 switching points. If only one low-level control is desired, the corresponding contacts must be connected. A 24 VDC supply voltage is required for the sensor.*

### Pump Element Assembly:

1 to 5 = number of the pump elements

5, 6, or 7 = piston diameter (mm)

KR = pump element adjustable, piston diameter 7 mm

### Extensions for the Motor Designation:

380 – 420,

440– 480 = standard multi-range motor for 380 – 420 V / 50 Hz and 440 – 480 V / 60 Hz

000 = pump without motor, however with connecting flange



Pump215

The 215 centralized lubrication pump is a high-pressure multi-line pump that can drive up to 15 adjustable pump elements and is used in progressive automated lubrication systems. It is capable of handling direct supply of lubrication points or as a central lubrication pump in large sized progressive systems.

215 pumps are available with a three-phased multi-range motor for 380–420 volts at 50 Hz or 440–480 volts at 60 Hz, with a single-range 500 volt, 50 Hz motor, with a free shaft end for use with other motors, or with an oscillating drive. Various gear ratios and reservoir sizes, with or without level control are available. The reservoir, available in 4, 8, 10 or 30 liter sizes, is suitable for both grease and oil.

## Popular 215 Models

Part No.	Description	Motor	Gear Ratio	Reservoir Size			Level Control	Number of Elements (Size)
				Liters	In <sup>3</sup>	Lbs.		
660-40707-1	P215-M100-30XYBU-13K7-380-420/440-480	3-phase	100:1	30	1830	60	yes	13 (7mm)
660-40724-4	P215-M490-10XYBU-2K7-380-420/440-480	3-phase	490:1	10	610	20	yes	2 (7mm)
660-40729-4	P215-M100-10XYBU-1K6-380-420/440-480	3-phase	100:1	10	610	20	yes	1 (6mm)
660-40751-1	P215-M100-10XYBU-6K7-380-420/440-480	3-phase	100:1	10	610	20	yes	6 (7mm)
660-40569-7	P215-F049-30XYN-13K7-000	free shaft end, no motor	49:1	30	1830	60	no	13 (7mm)
660-40751-6	P215-M100-10XYBU-2K6-380-420/440-480	3-phase	100:1	10	610	20	yes	2 (6mm)

*These pumps do not include a pressure relief valve which must be ordered separately.*

## Accessories

Part No.	Description	Tube Diameter	Pressure
624-25478-1	relief valve	6 mm tube via T-fitting	200 bar (2900 psi)
624-25479-1	relief valve	6 mm tube via T-fitting	350 bar (5076 psi)
624-25480-1	relief valve	8 mm tube via T-fitting	200 bar (2900 psi)
624-25481-1	relief valve	8 mm tube via T-fitting	350 bar (5076 psi)
624-25482-1	relief valve	10 mm tube via T-fitting	200 bar (2900 psi)
624-28483-1	relief valve	10 mm tube via T-fitting	350 bar (5076 psi)
304-17571-1	filling connector G 1/4" female* (BSPP)		
304-17574-1	filling connector G 1/2" female* (BSPP)		
600-25047-3	pump element K7		
600-25046-3	pump element K6		

\* For vacant outlet ports

## Technical Data

number of outlets	1 - 15				
threaded connection	G 1/4 female (BSPP)				
maximum operating pressure	350 bar (5076 psi)				
suitable lubricants	Grease up to NGLI 2 NGLI 3 on request oil with viscosity of min. 20 mm <sup>2</sup> /s				
max. lubricant output per piston stroke (adjustable from max. to 25%)	6 mm			7 mm	
	0.04 – 0.16 cm <sup>3</sup> (0.0025 – 0.010 in <sup>3</sup> )			0.057 – 0.23 cm <sup>3</sup> (0.0035 – 0.014 in <sup>3</sup> )	
approx. max lubricant output per hour (output increases by 20% for 60 Hz applications)	ratio:	490:1	100:1	49:1	7:1 (available only for free shaft end or oscillating drive)
	piston dia. 6 mm	27 cm <sup>3</sup> (1.6 in <sup>3</sup> )	132 cm <sup>3</sup> (8.0 in <sup>3</sup> )	268 cm <sup>3</sup> (16.4 in <sup>3</sup> )	
	piston dia. 7 mm	39 cm <sup>3</sup> (2.4 in <sup>3</sup> )	189 cm <sup>3</sup> (11.5 in <sup>3</sup> )	386 cm <sup>3</sup> (23.5 in <sup>3</sup> )	
operating temperature	-20 to 70° C (-4 to 158° F)				
level control	ultrasonic sensor for low and high-level control				

## Dimensions

Reservoir Size	Height	Width	Depth
4 liters* (without low-level control)	438 mm (17.25 in)	411 – 453 mm (16 – 18 in) depending on version	326 mm (13 in)
8 liters* (without low-level control)	539 mm (21.25 in)		
10 liters** (without low-level control)	520 mm (20.50 in)		
30 liters** (without low-level control)	760 mm (30.00 in)		
low-level sensor	30 mm (1.2 in)	125 mm (4.9 in)	65 mm (2.6 in)

\* transparent plastic

\*\* metal

# Identification Code Pump Models 215



The complete pump unit is defined by a type code on the nameplate.

## Examples of Type Codes:

## Description

P215-	M	490-	10XYBU-	5 K6-	380-420 / 440-480,500
P215-	F	100-	30XYN-	1 K7-	
P215-	P	007-	8XYN-	1 K7-	
P215-	M	049-	10XYBU-	2 KR-	000

## Basic Type (Housing Assembly):

P215 = housing assembly for all pump models

## Drive Assembly:

M = three-phase flanged motor the motor designation with extension e.g. for voltages, frequencies, explosion-proof design is added to the type code  
 F = free shaft end  
 P = oscillating drive

490 = gear ratio  $i = 1 : 490$   
 100 = gear ratio  $i = 1 : 100$   
 049 = gear ratio  $i = 1 : 49$   
 007 = gear ratio  $i = 1 : 7$  (only for F and P)

## Reservoir Assembly:

4 = 4 l plastic reservoir  
 8 = 8 l plastic reservoir  
 10 = 10 l sheet metal reservoir  
 30 = 30 l sheet metal reservoir  
 XY = reservoir for grease and oil  
 N = reservoir without level control  
 BU = reservoir with low- and high-level control (ultrasonic sensor)

*Note: The ultrasonic sensor is equipped with 2 switching points. If only one low-level control is desired, the corresponding contacts must be connected. A 24 VDC supply voltage is required for the sensor.*

## Pump Element Assembly:

1 to 15 = number of the pump elements  
 K6 or K7 = piston diameter (mm)

## Extensions for the Motor Designation:

380 - 420,  
 440 - 480 = standard multi-range motor for 380 - 420 V / 50 Hz and 440 - 480 V / 60 Hz  
 500 = single-range motor for network rated voltages 500 V / 50 Hz  
 000 = pump without motor, however with connecting flange

# Hydraulic Tool Lubrication Pump HTL101



The HTL101 pump is a hydraulically driven centralized lubrication pump. It is used mainly for the lubrication of hydraulic hammers. However, it can also be used for the lubrication of other hydraulically driven devices.

As a compact small-sized pump, the HTL101 is ideal for being mounted directly on the hammer or any other attached devices. The drive is effected via the hydraulic system of the carrier device. While the hammer or any other attached device operates, the pump continuously supplies lubricants such as chisel paste or greases up to NLGI class 2 to the connected lube point(s).

The pump is provided with lubricant by means of an exchangeable 400 g cartridge. The red follower piston in the cartridge serves as a visual control of the grease level. When the follower piston reaches the low-level position (control window), the cartridge must be replaced.

The pump output can be controlled via an adjustable fine throttle and can therefore be adopted to most hammer sizes.

The function of the pump can be checked by observing whether the eccentric shaft turns or whether the grease-level position of the follower piston changes.



HTLPump

The pump is suitable for operating at ambient temperatures down to -25° C (-13° F) as well as under water (10 m or 32.8 feet).

## Technical Data

output	0,22 cm <sup>3</sup> /stroke	0.13 in <sup>3</sup> /stroke
operating temperature	- 25° C to 80° C	- 13° F to 176° F
factory setting	4 rpm	4 rpm
adjustment on pressure relief valve	120 bar	1740 psi
max. hydraulic pressure	250 bar	3626 psi
min. hydraulic pressure	100 bar	1450 psi
oil pressure connector	M 16 x 1.5 mm	
oil return line connector	M 16 x 1.5 mm	
feed line connection	G 1/4	
feed line connections	3 different outlets (top, bottom, back)	

## Dimensions

Height (Cartridge Included)	Width	Depth
302 mm (11.9 in)	173 mm (6.8 in)	85 mm (3.4 in)
302 mm (11.9 in)	173 mm (6.8 in)	85 mm (3.4 in)



HTL Cartridge

## Popular HTL101 Models

Part No.	Model	Cartridge Capacity		Grease
		cm <sup>3</sup>	In <sup>3</sup>	
642-40816-1	HTL101	400	24.4	grease or chisel paste

## Popular HTL cartridges

Part No.	Cartridge with Grease	Part No.	Package with 12 Cartridges
542-34074-1	chisel paste	642-37608-1	chisel paste
542-34048-2	grease	642-34609-2	grease

# Multi-line and Progressive Systems

## SSV Metering Devices

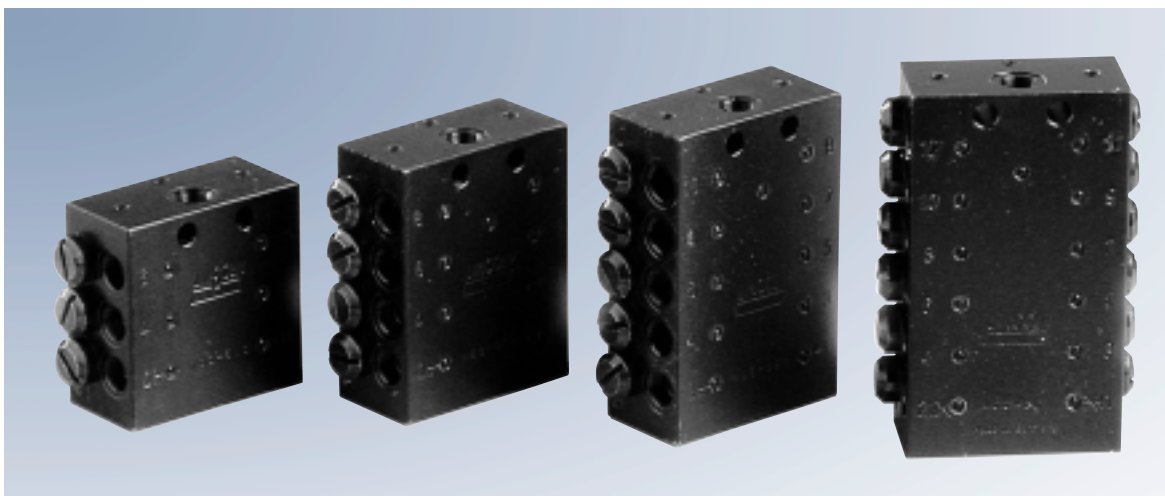

SSV Metering Devices

SSV progressive metering devices are piston-type metering devices which reliably dispense the lubricant volume fed to the inlet in predetermined single quantities.

By closing one outlet, the lubricant is fed to the next outlet below. This combining of outlets provides a large variety of metering possibilities. Additionally the internal porting avoids cumbersome external T-fittings. A special feature of the progressive metering device is that a previous feed line must supply lubricant before the next

one can be supplied. This makes the progressive system easy to visually or electrically monitor. It is available with 6 to 22 outlets and can be used for greases up to NLGI 2 or oils of at least 40 mm<sup>2</sup>/s.

Lincoln progressive metering devices in block design have no defect-prone rubber seals. They can therefore be used with no problem at high differential pressure (up to 100 bar between two outlets) and for a wide range of temperatures. The maximum operating pressure is 350 bar.

### Advantages

- No rubber seals
- Single block design
- Internal combining of outlets
- Exact lubricant metering
- Easy to monitor
- Fault-free replacement: should a metering device be exchanged, connection and output or adjustment errors are avoided
- High operating pressure

## Models

### No Monitoring

Inlet Size: R 1/8" Female (BSPP)			Number of Outlets	Inlet Size: 1/8" NPT Female	
Carbon Steel	303 Stainless Steel (VA 1.4305)	316Ti Stainless Steel (VA 1.4571)		Carbon Steel	303 Stainless Steel (VA 1.4305)
619-26473-1	619-27471-1	619-27824-1	6	619-27121-1	619-27792-1
619-25730-2	619-27473-1	619-27825-1	8	619-26396-2	619-27796-1
619-26841-1	619-27475-1	619-27889-1	10	619-26844-1	619-27800-1
619-25731-2	619-27477-1	619-27900-1	12	619-26398-2	619-27804-1
619-28862-1	619-29063-1		14		
619-28863-1	619-29064-1		16		
619-28864-1	619-29065-1		18		
619-28865-1	619-29066-1		20		
619-28866-1			22		





SSV6-K with Indicator Pin

## Indicator Pin (K)

For Visual Monitoring

Inlet Size: G 1/8" Female (BSPP)			Number of Outlets	Inlet Size: 1/8" NPT Female	
Carbon Steel	303 Stainless Steel (VA 1.4305)	316Ti Stainless Steel (VA 1.4571)		Carbon Steel	303 Stainless Steel (VA 1.4305)
619-26474-3	619-27471-1	619-27824-1	6	619-27122-1	619-27793-1
619-25754-4	619-27473-1	619-27825-1	8	619-26646-2	619-27797-1
619-26842-2	619-27475-1	619-27889-1	10	619-26845-2	619-27801-1
619-25755-4	619-27477-1	619-27900-1	12	619-26648-2	619-27805-1
619-28871-1	619-27814-1		14	619-28899-1	
619-28872-1	619-27725-1		16	619-28900-1	
619-28873-1	619-27973-1		18	619-28901-1	
619-28874-1	619-27947-1		20	619-28902-1	
619-28875-1			22		

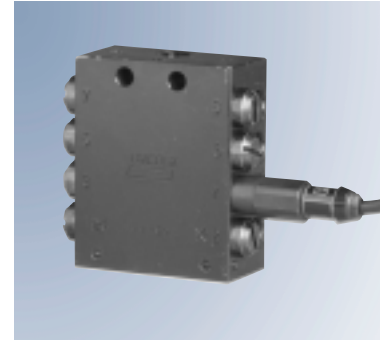

SSV8-N with Piston Detector

## SSV with Piston Detector (N)

For Electrical Monitoring. Standard Cable Length: 3 m (10')

Inlet Size: G 1/8" Female (BSPP)		Number of Outlets	Inlet Size: 1/8" NPT Female Carbon Steel
Carbon Steel	303 Stainless Steel (VA 1.4305)		
619-28257-1	619-29003-1	6	619-28653-1
619-28258-1		8	619-28654-1
619-28259-1	619-28529-1	10	
619-28260-1	619-29004-1	12	
619-28890-1		14	
619-28907-1		16	
619-28957-1		18	
619-28935-1		20	
619-29015-1		22	

Piston detector is also available with plug version – ask your Lincoln representative.

## Technical Data

number of outlets	6 to 22
maximum operating pressure	350 bar (5076 psi)
maximum differential pressure	100 bar (1450 psi)
metered volume per outlet and per stroke	0.2 cm <sup>3</sup> (0.012 in <sup>3</sup> )
outlet thread	M 10 x 1 (must use Lincoln outlet fittings)
materials available	<ul style="list-style-type: none"> <li>• steel, surface zinc-iron-coated, black chromed</li> <li>• stainless steel (1.4305)</li> <li>• stainless/acid proof steel for SSV6-12 (1.4571)</li> </ul>
operating temperature	-25 to 70° C (-13 to 158° F)

Note: Never close outlets 1 & 2!

## Dimensions

No. of Outlets	Height	Width	Depth
6	60 mm (2.4 in)	60 mm (2.4 in)	30 mm (1.2 in)
8	75 mm (3.0 in)		
10	90 mm (3.6 in)		
12	105 mm (4.2 in)		
14	120 mm (4.8 in)		
16	135 mm (5.4 in)		
18	150 mm (6.0 in)		
20	165 mm (6.6 in)		
22	180 mm (7.2 in)		



Check Valve, Threaded

## Threaded Fittings

Part No.	Description
504-30345-2	check valve for 4 mm tube
504-30344-4	check valve for 6 mm tube
504-31709-1	check valve for 4 mm tube – stainless steel
504-31705-1	check valve for 6 mm tube – stainless steel



Check Valve, Quickline

## Quickline – Plug-in Fittings

Part No.	Description
226-14091-4	check valve for 6 mm tube – high pressure (for primary metering devices)
226-14091-6	check valve for 4 mm tube – medium pressure (for secondary metering devices)
226-14091-2	check valve for 6 mm tube – medium pressure (for secondary metering devices)

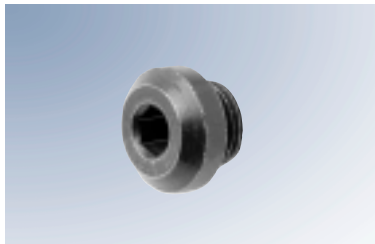

Outlet Closure Plug

## Other

Part No.	Description
303-17499-3	outlet closure plug M10 x 1
303-19346-2	outlet closure plug M10 x 1 - stainless steel
219-13798-3	o-ring for stainless steel closure plug*

\* Only required when closure plug does not seal

# SSVM Metering Devices



SSVM metering devices offer similar benefits as the SSV, but are smaller in size and output. This makes the SSVM ideal for compact applications – little space and short distances.

They can be monitored visually or electronically depending on the options selected. They are available with 6 to 12 outlets and can be used for grease up to NLGI 2, or oil of at least 40 cSt.

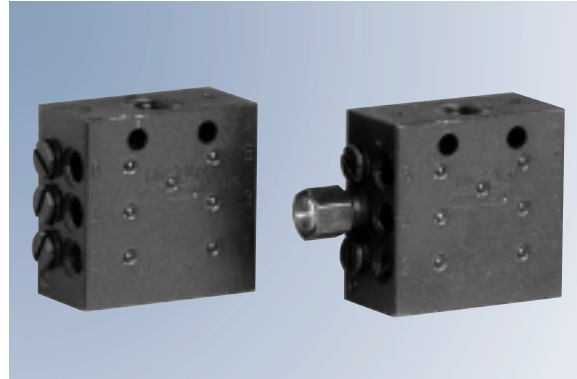

SSVM

## Standard

Inlet Size: G 1/8" Female (BSPP) Carbon Steel	Number of Outlets	Inlet Size: 1/8" NPT Female Carbon Steel
619-26761-1	6	619-26764-1
619-37044-1	8	619-26650-1
619-26846-1	10	619-26848-1
619-37049-1	12	619-26653-1

## With Indicator Pin (K)

Inlet Size: G 1/8" Female (BSPP) Carbon Steel	Number of Outlets	Inlet Size: 1/8" NPT Female Carbon Steel
619-26762-3	6	619-26765-3
619-37045-3	8	619-26651-3
619-26847-2	10	619-26849-2
619-37050-3	12	619-26654-3

## With Indicator Pin and Limit Switch (KS)

Inlet Size: G 1/8" Female (BSPP) Carbon Steel	Number of Outlets	Inlet Size: 1/8" NPT Female Carbon Steel
619-27078-1	6	
619-27079-1	8	
619-27080-1	10	
619-27081-1	12	

## With Indicator Pin and Proximity Switch (KN)

Inlet Size: R 1/8" Female (BSPP) Carbon Steel	Number of Outlets	Inlet Size: 1/8" NPT Female Carbon Steel
619-27667-1	6	
619-27668-1	8	
619-27669-1	10	
619-27670-1	12	

## With Indicator Pin and Adapter for Proximity Switch (KA)

Inlet Size: R 1/8" Female (BSPP) Carbon Steel	Number of Outlets	Inlet Size: 1/8" NPT Female Carbon Steel
619-27663-1	6	
619-27664-1	8	
619-27665-1	10	
619-27666-1	12	

## Technical Data

number of outlets	6 to 12
maximum operating pressure	200 bar (2900 psi)
maximum differential pressure	40 bar (580 psi)
metered volume per outlet	0.07 cm <sup>3</sup> (0.0043 in <sup>3</sup> )
outlet thread	M 8 x 1 (must use Lincoln outlet fittings)
materials available	steel, surface zinc-iron-coated, black chromed
operating temperature	-25 to 70°C (-13 to 158°F)

*Note: Never close outlets 1 & 2!*

## Dimensions

Number of outlets	Height	Width	Depth
6	48.5 mm (1.94 in)	50 mm (2.0 in)	25 mm (1.0 in)
8	60 mm (2.4 in)		
10	71.5 mm (2.86 in)		
12	83 mm (3.32 in)		

## SSVM Accessories

Part No.	Description
threaded connections	
519-31661-1	check valve for 4 mm tube
Quicklinc plug-in fittings	
226-14091-5	check valve for 4 mm tube
other	
303-17530-1	outlet closure plug M8 x 1
209-12464-7	outlet copper washer for closure plug

# SSV-FL SSV Flanged Type Metering Device



The SSV-FL is based on the standard SSV, flanged to a manifold block. Ideal for rigorous conditions such as those found in steel plants. This design allows for connections up to dia.10 mm tubing. Additionally, the metering devices can easily be exchanged during maintenance routines without having to disconnect lubricant lines – thus saving valuable time.

They can be monitored visually (SSV-FL-K) or electronically via a proximity switch (SSV-FL-KN). They are available with 1 to 12 outlets and can be used for grease up to NGLI 2 or oil of at least 40 cST.



SSV-FL10-K

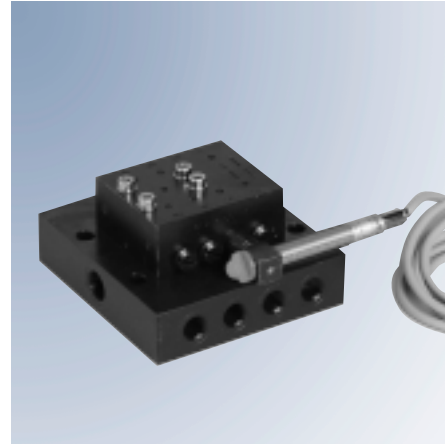

SSV-FL8-KN

## Models

SSV-FL-K	Number of Outlets	SSV-FL-KN
619-40646-1	1	619-40678-1
619-40646-2	2	619-40678-2
619-40646-3	3	619-40678-3
619-40646-4	4	619-40678-4
619-40646-5	5	619-40678-5
619-40646-6	6	619-40678-6
619-40646-7	7	619-40678-7
619-40646-8	8	619-40678-8
619-40646-9	9	619-40678-9
619-40647-1	10	619-40679-1
619-40647-2	11	619-40679-2
619-40647-3	12	619-40679-3

## Technical Information

number of outlets	1 to 12
maximum operating pressure	300 bar (4350 psi)
maximum differential pressure	100 bar (1450 bar)
metered volume per outlet and per stroke	0.2 cm <sup>3</sup> (0.012 in <sup>3</sup> )
outlet thread	G 1/4 female (BSPP)
inlet thread	G 3/8 female (BSPP)
materials available	steel, surface zinc-iron-coated, black chromed
operating temperature	-25 to +70°C (- 13 to 158°F)

# SSV-FL SSV Flanged Type Metering Device

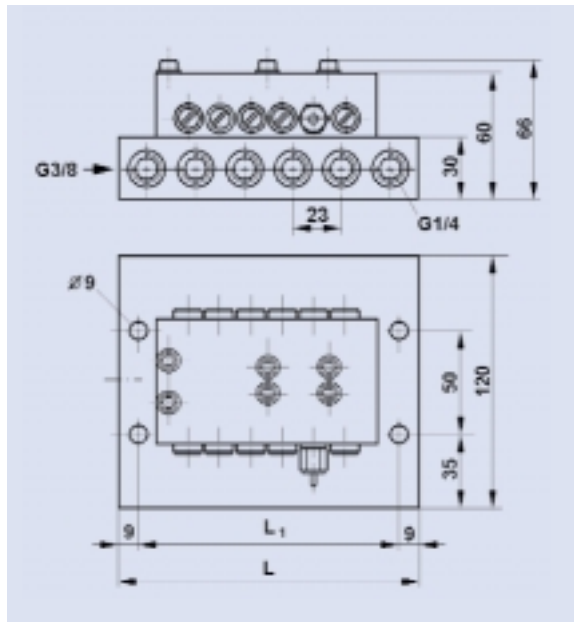

Dimensions of SSV-FL

## SSV-FL Accessories

Part No.	Description
223-13052-1	outlet check valve for 6 mm tube
223-13052-2	outlet check valve for 8 mm tube
223-13052-3	outlet check valve for 10 mm tube

## Dimensions

Number of outlets	Length	Width	Depth
1	97 mm (3.88 in)	120 mm (4.8 in)	66 mm (2.64 in)
2			
3			
4	112 mm (4.48 in)		
5	97 mm (3.88 in)		
6			
7	112 mm (4.48 in)		
8			
9	127 mm (5.08 in)		
10			
11	142 mm (5.68 in)		
12			

# Index

## Multi-line and Progressive Systems



Part No.	Page	Part No.	Page	Part No.	Page
09012	14	550-36971-3	12	619-26848-1	29
09024	14	600-25046-3	21	619-26849-2	29
09212	14	600-25047-3	21	619-27078-1	29
09224	14	600-26178-1	18	619-27079-1	29
09412	14	600-26875-2	18	619-27080-1	29
09424	14	600-26876-2	18	619-27081-1	29
09812	14	600-26877-2	18	619-27121-1	25
09824	14	600-26878-1	18	619-27122-1	26
94222	14	600-28750-1	15	619-27471-1	25
94422	14	604-25103-1	6	619-27472-1	26
94822	14	604-25105-2	8	619-27473-1	25
209-12464-7	30	604-25109-2	6	619-27474-1	26
219-13798-3	28	604-25111-3	8	619-27475-1	25
223-13052-1	32	604-25129-2	8	619-27476-1	26
223-13052-2	32	604-25130-3	8	619-27477-1	25
223-13052-3	32	604-27162-1	6	619-27663-1	30
226-14091-2	30	604-27213-1	8	619-27664-1	30
226-14091-4	30	604-27223-1	8	619-27665-1	30
226-14091-5	30	604-28766-1	7	619-27666-1	30
226-14091-6	30	604-28767-1	7	619-27667-1	30
226-14105-5	15	604-28768-1	7	619-27668-1	30
233-13090-9	15	604-28769-1	7	619-27669-1	30
233-13124-8	15	619-25730-2	25	619-27670-1	30
234-13188-2	17	619-25731-2	25	619-27725-1	25
236-10127-1	17	619-25754-4	26	619-27792-1	25
244-14161-1	15	619-25755-4	26	619-27793-1	26
244-14164-1	7	619-26396-2	25	619-27796-1	25
303-17499-3	28	619-26398-2	25	619-27797-1	26
303-17530-1	30	619-26473-1	25	619-27800-1	25
303-19346-2	28	619-26474-3	26	619-27801-1	26
304-17571-1	18/21	619-26646-2	26	619-27804-1	25
304-17574-1	18/21	619-26648-2	26	619-27805-1	26
504-30344-4	28	619-26650-1	29	619-27814-1	25
504-30345-2	28	619-26651-3	29	619-27824-1	25
504-31705-1	28	619-26653-1	29	619-27825-1	25
504-31709-1	28	619-26654-3	29	619-27854-1	26
519-31661-1	30	619-26761-1	29	619-27855-1	26
538-36763-4	15	619-26762-3	29	619-27889-1	25
538-36763-5	15	619-26764-1	29	619-27900-1	25
542-34048-2	24	619-26765-3	29	619-27947-1	26
542-34074-1	24	619-26841-1	25	619-27973-1	25
550-36791-1	12	619-26842-2	26	619-27974-1	26
550-36970-1	12	619-26844-1	25	619-28201-1	26
550-36970-2	12	619-26845-2	26	619-28257-1	27
550-36970-3	12	619-26846-1	29	619-28258-1	27
550-36971-2	12	619-26847-2	29	619-28259-1	27



# Index

## Multi-line and Progressive Systems



Part No.	Page	Part No.	Page	Part No.	Page
619-28260-1	27	624-25479-1	21	655-40655-9	18
619-28529-1	27	624-25480-1	21	655-40673-2	18
619-28653-1	27	624-25481-1	21	655-40704-2	18
619-28654-1	27	624-25482-1	21	660-40569-7	21
619-28862-1	25	624-28070-1	18	660-40707-1	21
619-28863-1	25	624-28483-1	21	660-40724-4	21
619-28864-1	25	624-28774-1	18	660-40729-4	21
619-28865-1	25	624-28859-1	15	660-40751-1	21
619-28866-1	25	624-28891-1	15	660-40751-6	21
619-28871-1	26	624-28892-1	15	810-55291-1	17
619-28872-1	26	624-28894-1	15	P30131211151	9
619-28873-1	26	624-28931-1	15	P30131411110	10
619-28874-1	26	638-37548-1	15	P30131411151	9
619-28875-1	26	638-37549-1	15	P30142611111	9
619-28890-1	27	638-37549-2	15	P30142811111	9
619-28899-1	26	638-37561-1	15	P30161211151	9
619-28900-1	26	642-37608-1	24	P30161411110	10
619-28901-1	26	642-37609-2	24	P30161411151	9
619-28902-1	26	642-40816-1	24	P30162611111	9
619-28907-1	27	644-37426-1	14	P30162811111	9
619-28935-1	27	644-40550-4	14	P30191211151	9
619-28957-1	27	644-40583-3	14	P30191411110	10
619-29003-1	27	644-40645-2	14	P30191411151	9
619-29004-1	27	644-40645-3	14	P30192611111	9
619-29015-1	27	644-40716-2	14	P30192811111	9
619-29063-1	25	644-40717-5	14	P31131211151	9
619-29064-1	25	644-40718-1	14	P31131411110	10
619-29065-1	25	644-40718-5	14	P31131411151	9
619-29066-1	25	644-40718-7	14	P31142611111	9
619-37044-1	29	644-40718-8	14	P31142811111	9
619-37045-3	29	644-40719-5	14	P31161211151	9
619-37049-1	29	644-40719-6	14	P31161411110	10
619-37050-3	29	644-40721-5	14	P31161411151	9
619-40646-1	31	644-40762-2	14	P31162611111	9
619-40646-2	31	644-40824-1	17	P31162811111	9
619-40646-3	31	644-40824-2	17	P31191211151	9
619-40646-4	31	644-40826-1	17	P31191411110	10
619-40646-5	31	644-40827-1	17	P31191411151	9
619-40646-6	31	650-40765-4	10	P31192611111	9
619-40646-7	31	650-40765-5	10	P31192811111	9
619-40646-8	31	650-40765-6	10	P32131210531	11
619-40646-9	31	650-40768-3	10	P32131410531	11
619-40647-1	31	650-40768-4	10	P32161210531	11
619-40647-2	31	650-40768-5	10	P32161410531	11
619-40647-3	31	655-40654-2	18	P32191210531	11
624-25478-1	21	655-40655-3	18	P32191410531	11

Productivity is key in today's global economy. Lincoln – the leader in knowledge, technology and service for lubrication systems – is key to your Total Productivity Maintenance System.

Now you got our catalogue about "Multi-line and Progressive Systems". Further Lincoln catalogues, brochures, owner manuals and technical information are available at your local Lincoln office, distributor or sales agency, or at Lincoln GmbH & Co. KG, Walldorf, Germany (see address on last page).

For more information just get in touch – phone, fax, or click: [www.lincolnindustrial.com/Locator/Distributor](http://www.lincolnindustrial.com/Locator/Distributor) to find your nearest Lincoln representative.

**You know: Information is key to your productivity.**

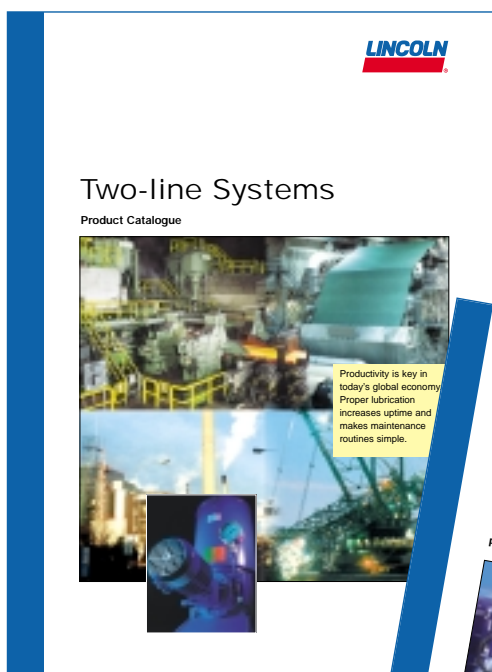

# Lincoln's Global Distribution Network Is the Best in the Industry



In all levels of service – lubrication system evaluation, custom-engineered system installation, or the supply of top-quality products – your Lincoln distributor makes certain you always get the very best value.

#### **Systems House Distributors**

Our systems house distributors offer the highest level of expertise available in the industry. They custom-design systems with the exact combination of Lincoln components you need. Then they install the system in your plant with experienced technicians or work with your personnel to make sure the job is done correctly. Each distributor stocks a full inventory of pumps, metering devices, con-trollers, monitors and accessories. Each continues to meet our stringent requirements for product, systems and service knowledge. From St. Louis to Singapore, Walldorf and worldwide, Lincoln's top-of-the-industry systems house distributors will be there when and where you need them.

**For the nearest authorized Lincoln sales and service representative, call:**

#### **Americas:**

St. Louis, Missouri  
Phone +1 314.679.4200  
Fax: +1 800.424.5359

#### **Europe/Middle East/Africa:**

Walldorf, Germany  
Phone + 49.6227.33.0  
Fax: + 49.6227.33.259

#### **Asia/Pacific:**

Singapore  
Phone + 65.65627960  
Fax: + 65.65629967



Heinrich-Hertz-Str. 2-8  
D-69190 Walldorf  
Germany

Phone + 49.6227.33.0  
Fax + 49.6227.33.259  
[www.lincolnindustrial.de](http://www.lincolnindustrial.de)  
[lincoln@lincolnindustrial.de](mailto:lincoln@lincolnindustrial.de)

Form W-113-A-0103  
© Copyright 2003  
Printed in Germany

